

User manual

TORQUE REACTION ARM

SUSPENDED SLIDER

WITH / WITHOUT POSITION CONTROL

Series: **SLIDER / COMPACT / CARTESIAN / BA**



EN

60354-12/22

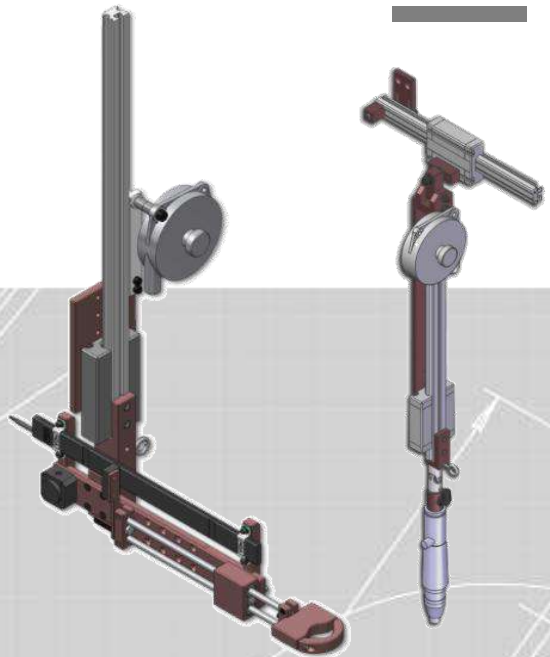

CONTENTS

REMARKS ABOUT THE MANUAL	4
Symbols	4
Acronyms	4
1. INFORMATION	5
1.1 IMPORTANT	5
1.2 Product reference	5
1.3 General equipment description	6
1.4 Standard equipment presentation	7
1.4.1 Sliding torque reaction arm	7
1.4.2 Sliding torque reaction arm with position control (PC and RPC)	14
1.5 Technical specifications	17
1.5.1 Slider 8 / 20 and Slider 8 / 20 / 50 Compact	17
1.5.2 Slider 150 Compact	19
1.5.3 Slider 15 cart	20
1.5.4 Slider BA / R / PC / RPC	21
1.5.5 Slider BA mounting plate	25
2. STARTING UP	26
2.1 Workstation description	26
2.2 Unpacking	27
2.3 Configuration	27
2.4 Installation	28
2.4.1 Standard clamp tool installation	28
2.4.2 Rotating clamp mounting	29
2.4.3 Shift adjustment B min. / B max (SLIDER BA / BA R)	29
2.4.4 Inclination adjustment (Slider BA R and RPC)	30
2.4.5 Balancer kit installation	30
2.4.6 Encoders verification (Slider BA PC and RPC series)	31
2.4.7 Height adjustment (Slider 8 / 20 Compact)	32

3. SETTINGS	33
3.1 Balancer setting	33
4. USE	34
4.1 Standard use	34
4.2 Position control use	34
5. MAINTENANCE	35
5.1 Maintenance	35
5.1.1 General maintenance	35
5.1.2 Sliding play adjustment	35
5.2 Troubleshooting	36
5.3 Spare parts	37
5.4 Phone support	37
5.5 After-sales return	38
5.5.1 Download the after-sales return form	38
5.5.2 Send your equipment	39
5.6 On-site repair	39
5.7 Warranty	40
6. SAFETY	41
6.1 General provisions	41
6.2 Residuals risks	42
6.2.1 Pinching or Cutting Risks	42
6.2.2. Injury Risk	42
6.3 Contra-indications	42
7. STANDARDS	43
7.1 Manufacturer details	43
7.2 Markings	43
7.3 Transport and storage	44
7.3.1 Transport	44
7.3.2 Storage	44
7.4 Recycling and end of service life	44
8. ANNEXES	45
8.2 EC Declaration of Conformity	45

REMARKS ABOUT THE MANUAL

Symbols



Information

This warning symbol indicates important information (for example: damage), but no hazard.



Information

Information to view in your customer area on the www.doga.fr web site.



Caution

This warning symbol indicates a low risk that may lead to minor or moderate injuries if not avoided.



Wear personal protection equipment

This symbol indicates the need to wear protective gloves.



Warning

This warning symbol indicates a moderate risk that may lead to severe or fatal injuries if not avoided.

Acronyms

BA : Assistance arm

PC : Positioning control

R : Double articulation

G : Pneumatic balancing

1. INFORMATION

1.1 IMPORTANT

The tool supplied with this manual may have been altered to meet specific needs.

If this is the case, when ordering a replacement or spare parts, please indicate the tool item code featured on the delivery document, or contact **DOGA** at **+33 1 30 66 41 41** indicating the approximate delivery date. You will then be sure to get the required tool and/or parts.

1.2 Product reference





Designation	Slider torque reaction arm
Type	<ul style="list-style-type: none"> Slider 8/20 Slider 8/20/50/150/300 Compact Slider 15 CARTESIAN ... Slider BA ... Slider BA ... R Slider BA ... PC Slider BA ... RPC

1.3 General equipment description

DOGA's Slider torque reaction arms are available in several configurations. They are designed to be easily installed above workstations, and are ideal for vertical tightening operations.

They are used for distinct and complementary functions:

- a) Elimination of the torque reaction effect of hand-tools with rotary motors such as screwdrivers, drills or tappers. They guarantee the dampening of shocks and vibrations delivered by these tools, thus preventing musculoskeletal disorders.
- b) Ensure the suspension and balancing of the tools.
- c) Guarantee perfect perpendicularity between the tool and the work surface.
- d) With encoders mounted to the arms (PC version), they can be used for position control.

		
Slider	Slider Compact	Slider Cartesian
		
Slider BA / BA PC		Slider BA R / BA RPC

1.4 Standard equipment presentation

1.4.1 Sliding torque reaction arm

1.4.1.1 Slider 8 and 20

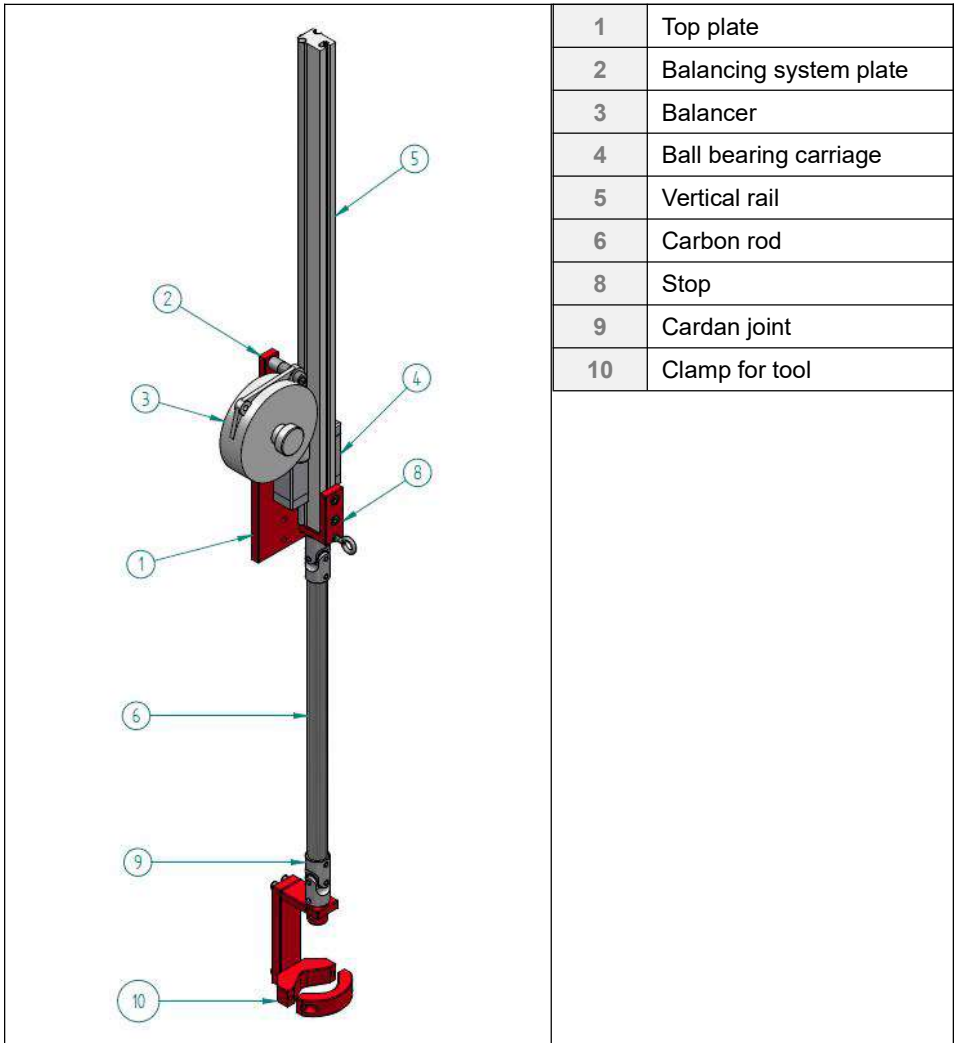

1.4.1.2 Slider 8 Compact

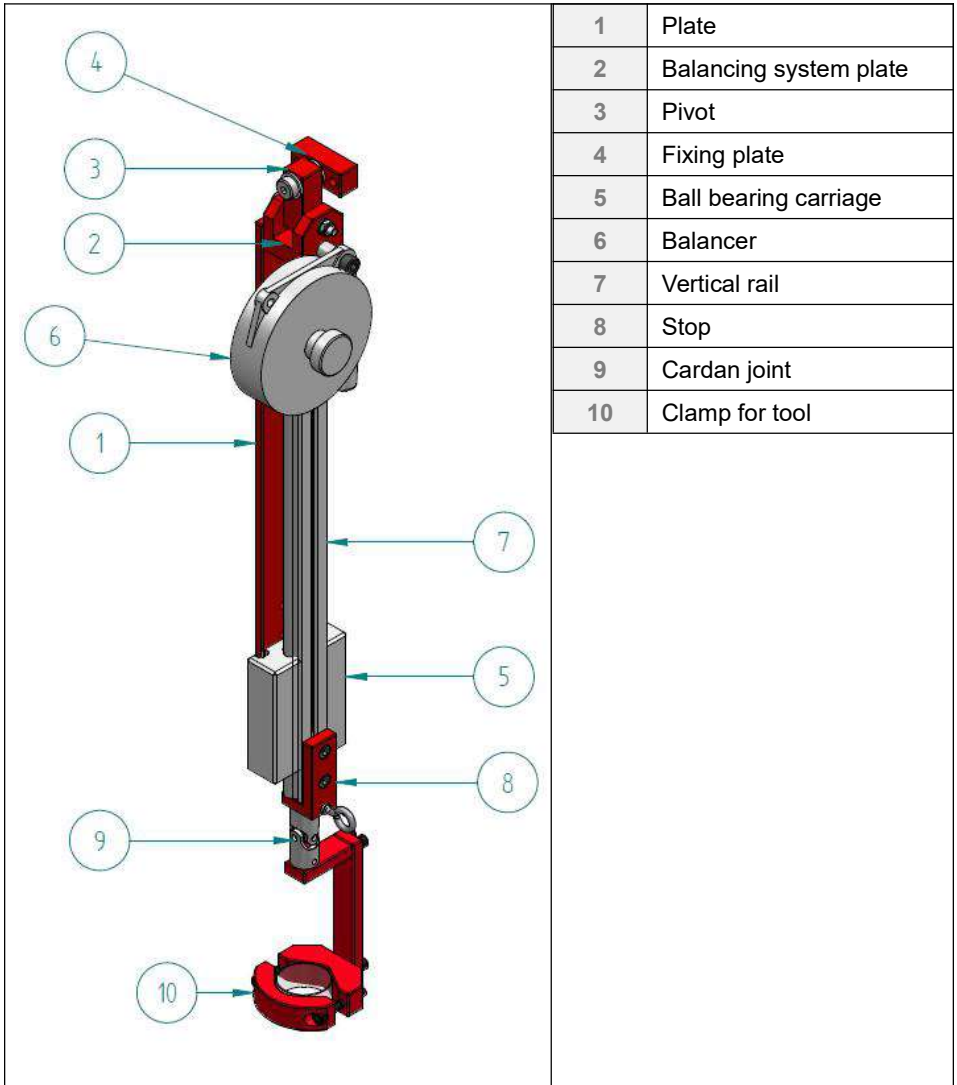

1.4.1.3 Slider 20 Compact

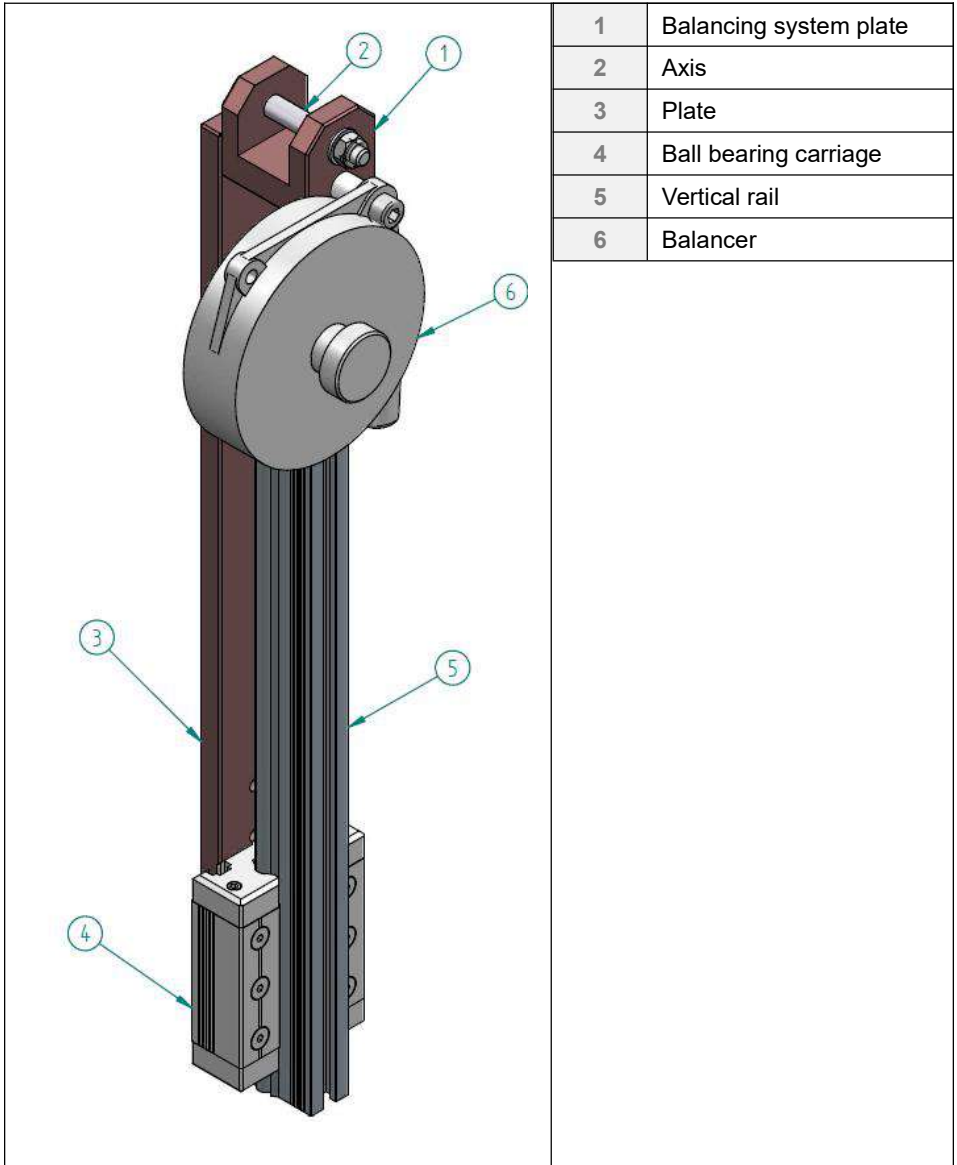

1	Balancing system plate
2	Axis
3	Plate
4	Ball bearing carriage
5	Vertical rail
6	Balancer

1.4.1.4 Slider 50 Compact

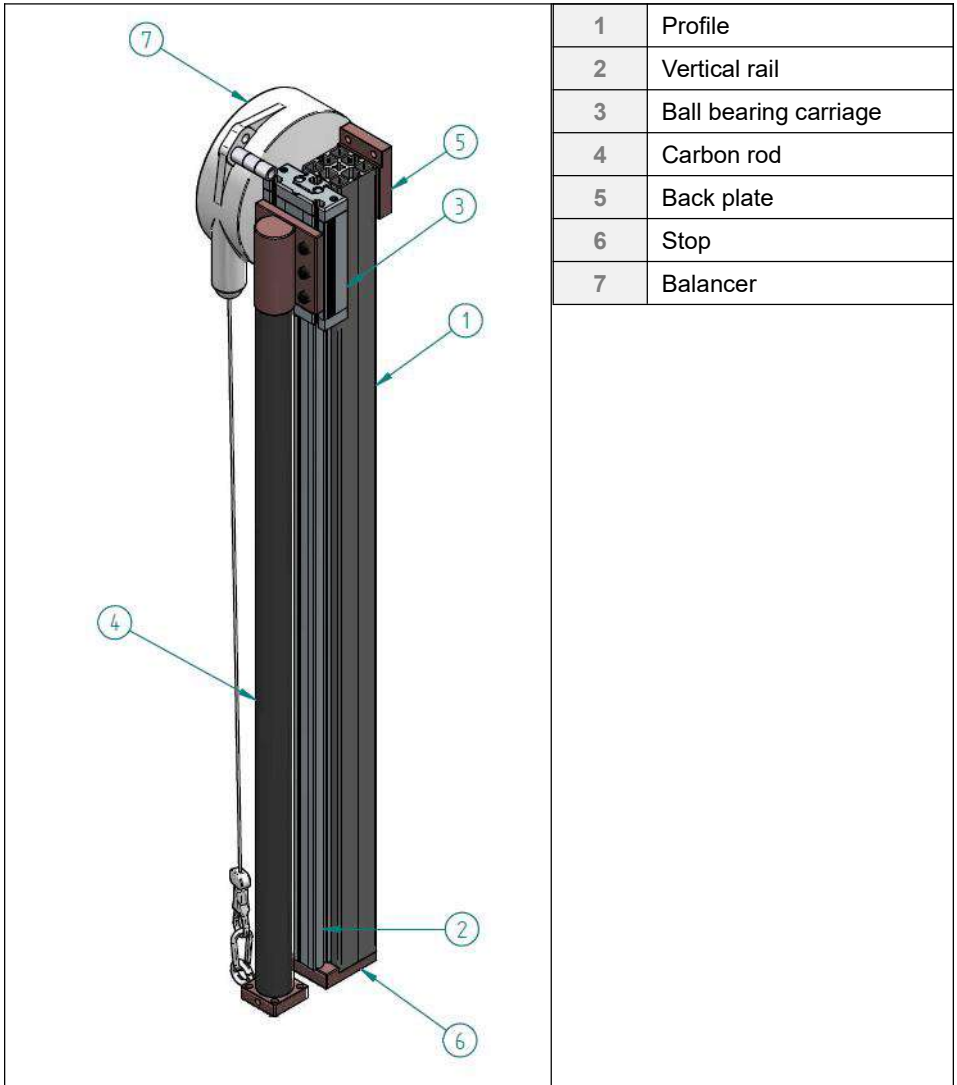

1	Profile
2	Vertical rail
3	Ball bearing carriage
4	Carbon rod
5	Back plate
6	Stop
7	Balancer

1.4.1.5 Slider BA and BA R series

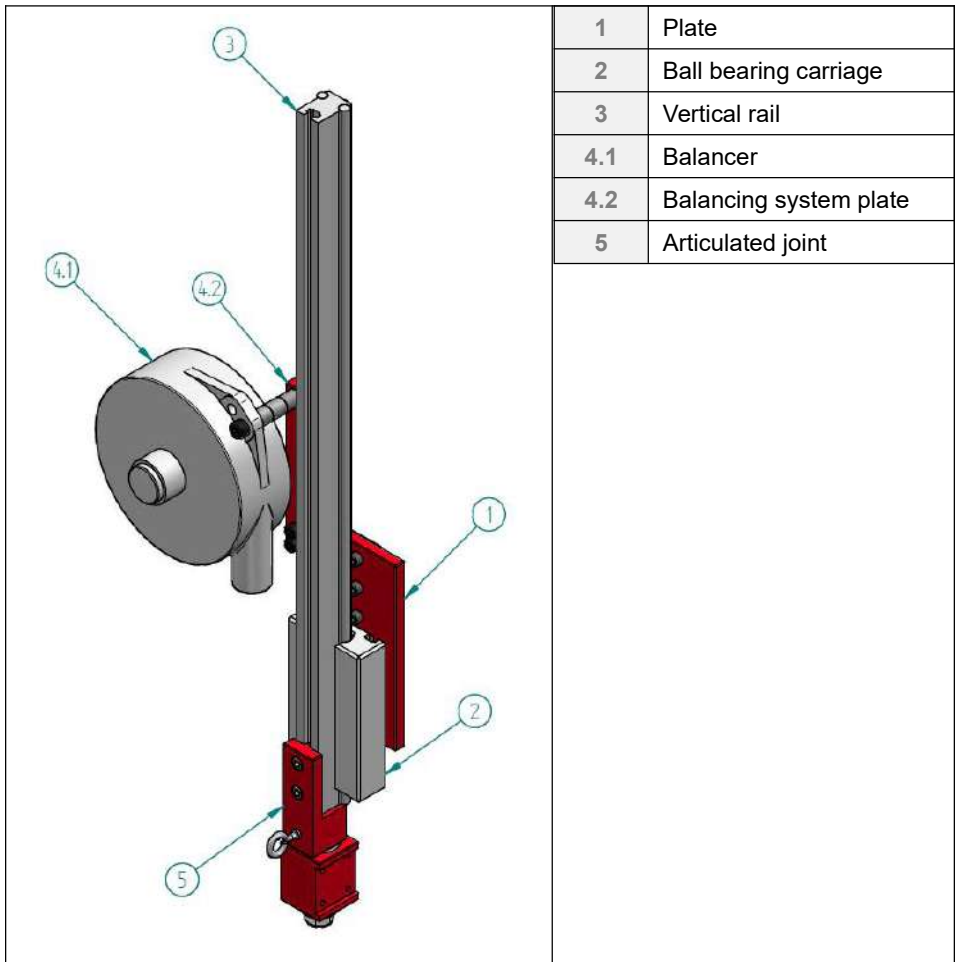

Rep.	SLIDER BA 12/R	SLIDER BA 25/R	SLIDER BA 40/R	SLIDER BA 100/R
4.1	4-1284444	4-1200008	4-1200050 (440) 4-1200149 (640) 4-1200149 (840)	2 x 4-120008 (440) 4-1200008 + 4-120005 (640) 2 x 4-1200050 (840)

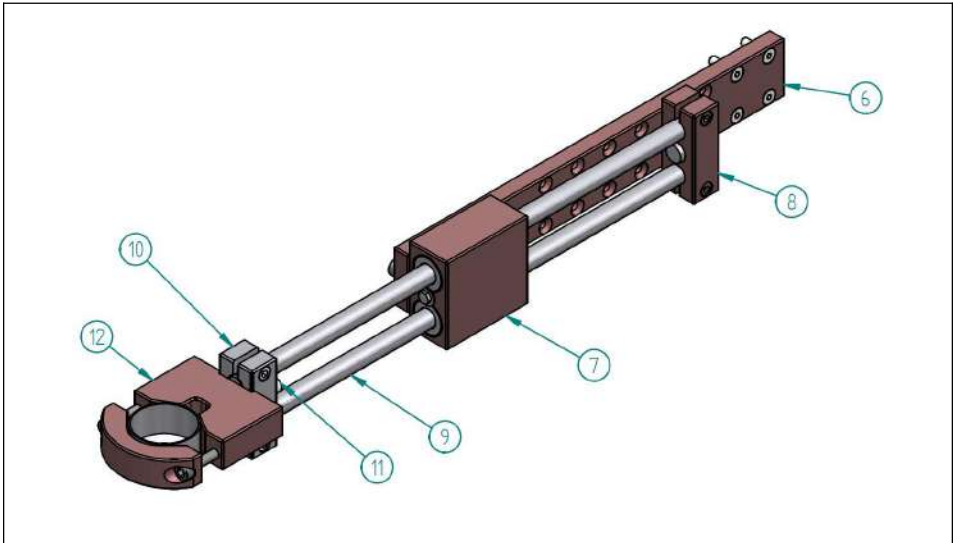

6	Primary arm plate
7	Thrust ball bearing
8	Back flange
9	Set of 2 slides
10	Front flange
11	Magnet
12	Clamp

Rep.	SLIDER BA 12	SLIDER BA 25	SLIDER BA 40	SLIDER BA 100
6	4-5200155	4-5200175	4-5200189	4-5200205
7	4-5200156	4-5200176	4-5200190	4-5200206
8	4-5200157	4-5200177	4-5200191	4-5200207
9	4-5200158	4-5200178	4-5200192	4-5200208
10	4-5200159	4-5200180	4-5200193	4-5200209
11	4-5200168	4-5200181	4-5200194	4-5200223
12	4-5200169	4-5200182	4-5200195	4-5200224

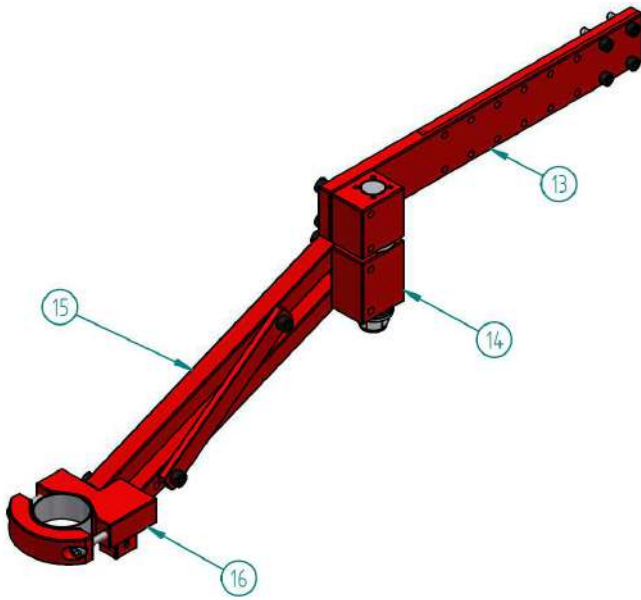

13	Primary arm plate
14	Articulated joint
15	Secondary arm plate
16	Clamp

Rep.	SLIDER BA 12 R	SLIDER BA 25 R	SLIDER BA 40 R	SLIDER BA 100 R
13	4-5200238	4-5200251	4-5200260	4-5200269
14	4-5200243	4-5200252	4-5200261	4-5200270
15	4-5200244	4-5200253	4-5200262	4-5200271
16	4-5200245	4-5200254	4-5200263	4-5200272

Complete spare parts list on request.

1.4.2 Sliding torque reaction arm with position control (PC and RPC)

1.4.2.1 Slider BA PC / RPC series

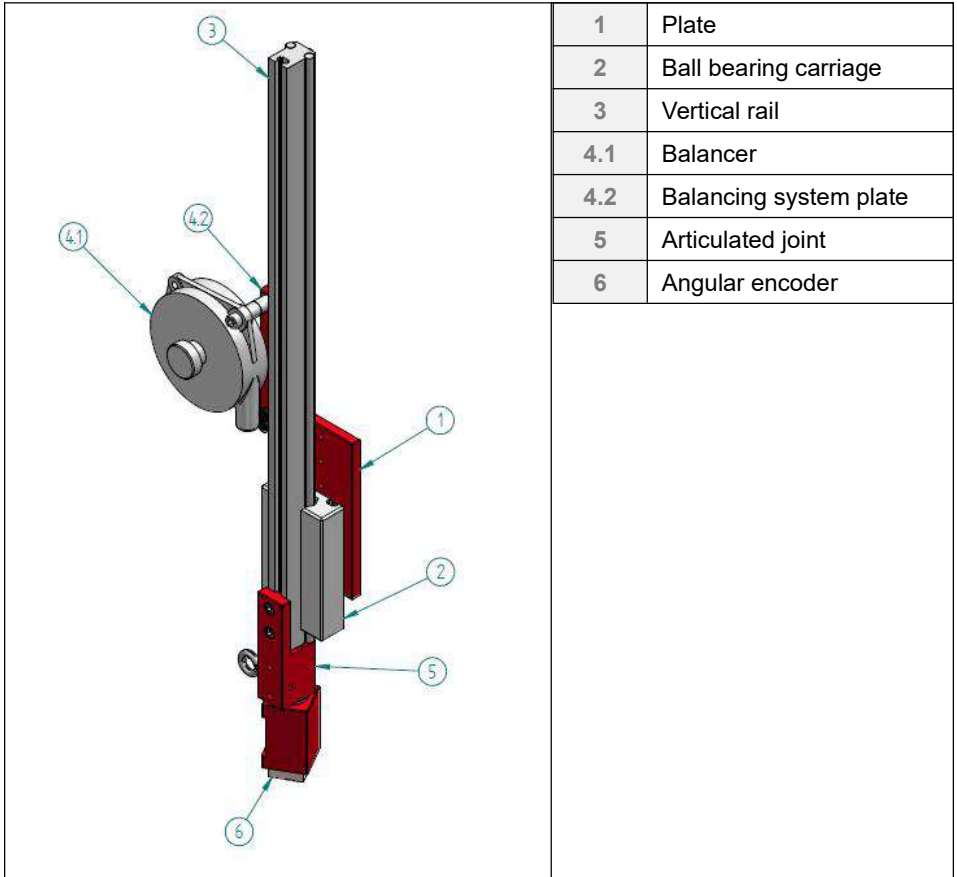

Rep.	SLIDER BA 12/R	SLIDER BA 25/R	SLIDER BA 40/R	SLIDER BA 100/R
4.1	4-1284444	4-1200008	4-1200050 (440) 4-1200149 (640) 4-1200149 (840)	2 x 4-1200008 (440) 4-1200008 + 4-1200005 (640) 2 x 4-1200050 (840)
6	4-5200484			

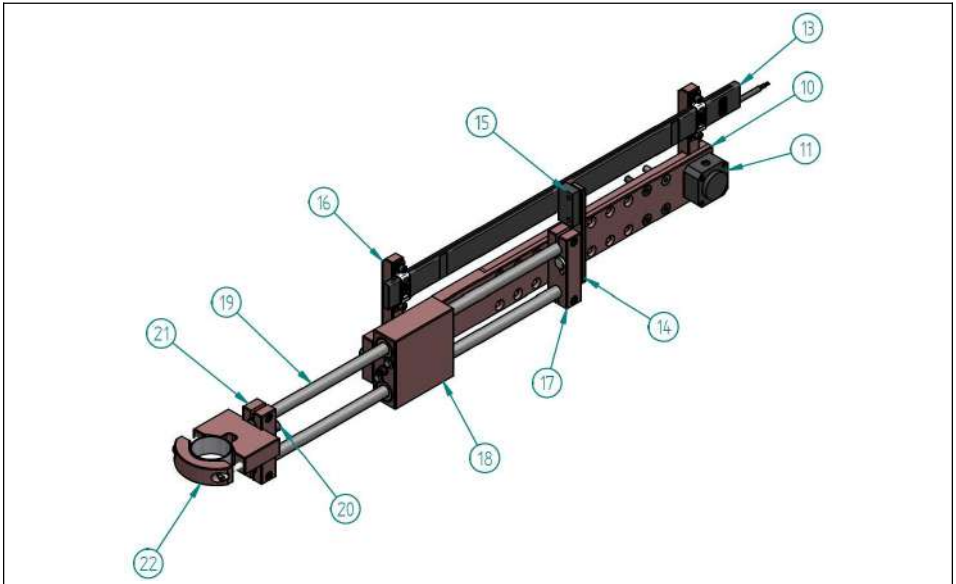

10	Primary arm plate
11	Connection unit
13	Linear encoder
14	Magnet support
15	Magnet encoder
16	Encoder support
17	Back flange
18	Thrust ball bearing
19	2 axis set
20	Magnet
21	Front flange
22	Clamp

Rep.	BA 12 PC	BA 25 PC	BA 40 PC
11	4-5200488	4-5200488	4-5200488
13	4-5200715	4-5200715	4-5200716

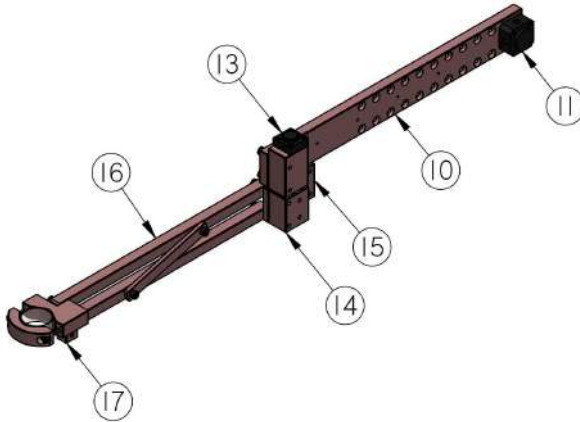

10	Primary arm plate
11	Junction box
13	Articulation encoder
14	Articulated joint
15	Rotational stop
16	Secondary arm plate
17	Clamp

Rep.	BA 12 RPC	BA 25 RPC	BA 25 RPC/600
11	4-5200488	4-5200488	
13	4-5200485	4-5200485	4-5200560
16	4-5200244	4-5200253	4-5200514
17	4-5200245	4-5200254	

Rep.	BA 40 RPC	BA 40 RPC/800	BA 100 RPC	BA 100 RPC/900
11	4-5200488		4-5200488	
13	4-5200486	4-5200561	4-5200487	4-5200562
16	4-5200262	4-5200612	4-5200271	4-5200700
17	4-5200263		4-5200272	

1.5 Technical specifications

1.5.1 Slider 8 / 20 and Slider 8 / 20 / 50 Compact

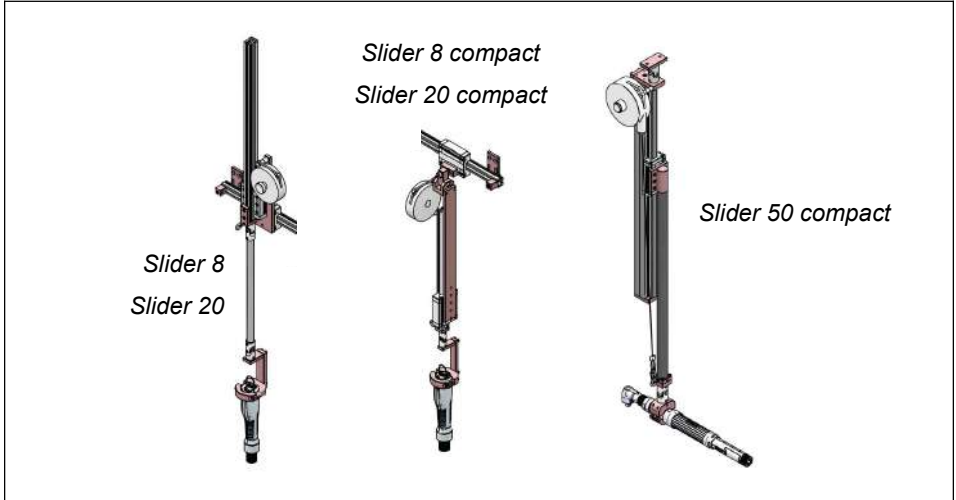

Design.	Torque max		Ø Tools min-max		Max. Load	
	(Nm)	(lbf.in)	(mm)	(in)	(kg)	(lbs)
Slider 8	8	70,1	28/52	1,10/2,04	1,2	2,64
Slider 8 Compact	8	70,1				
Slider 20	20	177			On request	2,2
Slider 20 Compact	20	177				
Slider 50 Compact	50	442,5	On request		3	6,61



Warning

Never use torque arms beyond listed torque ratings.

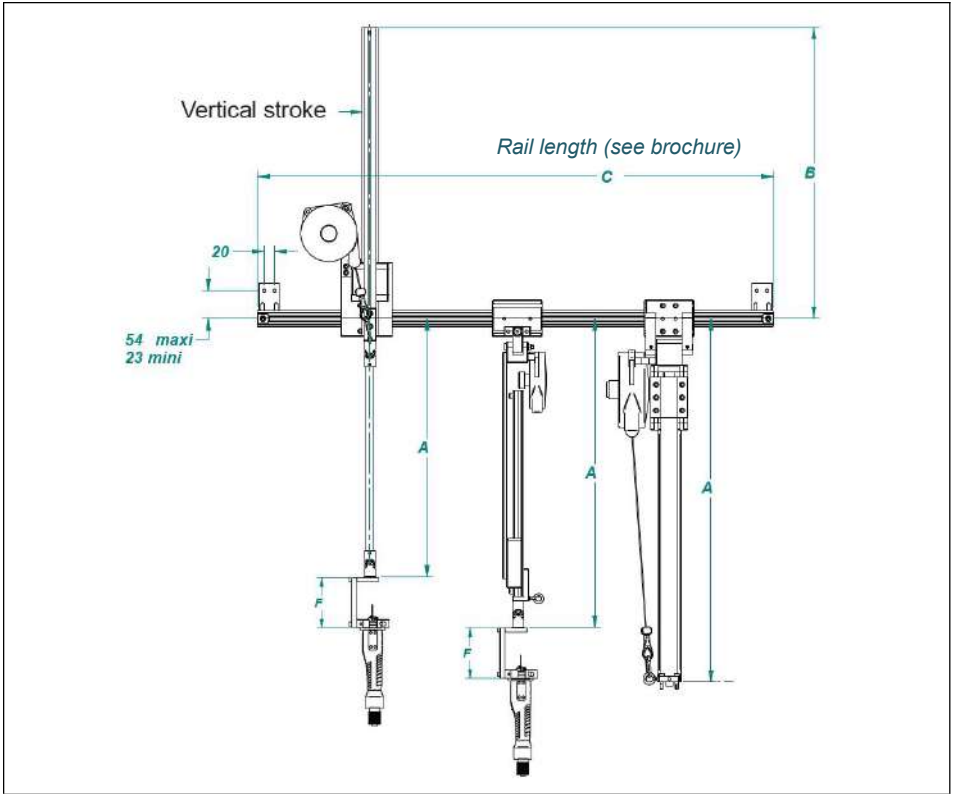

Design.	A		B		Vertical Stroke		F	
	(mm)	(in)	(mm)	(in)	(mm)	(in)	(mm)	(in)
Slider 8	500	21,65	565	22,24	450	17,72	120	4,72
Slider 20	599	23,58	599	23,58	450	17,72	120	4,72
Slider 8	550 - 600	21,65 - 23,62	N.A.		270	10,63	120	4,72
Compact	750 - 800	29,52 - 31,49			470	18,50		
Slider 20	488 - 538	19,21 - 21,18	N.A.		270	10,63	On request	
Compact	688 - 738	27,08 - 29,05			470	18,50		
Slider 50	705	27,75	N.A.		470	18,50		
	905	35,63			670	26,38		
	1005	39,57			870	34,25		

1.5.2 Slider 150 Compact



Design.	Torque max		Ø Tools min-max		Max. Load	
	(Nm)	(lbf.in)	(mm)	(in)	(kg)	(lbs)
Slider 150 compact	150	1327,61	Max. 63	Max 2,48	5	11,02

Design.	Vertical Stroke		A min-max	
	(mm)	(in)	(mm)	(in)
Slider 150 compact	600	23,62	1100 - 1700	43,31 - 66,93
	800	31,50	1300 - 2100	51,18 - 82,68
	1000	39,37	1500 - 2500	59,05 - 98,42

Drawings on request.



Warning

Never use torque arms beyond listed torque ratings.

1.5.3 Slider 15 cart

Design.	Torque max		Ø Tool min-max		Max. Load		Vertical Stroke Z	
	(Nm)	(lbf.in)	(mm)	(in)	(kg)	(lbs)	(mm)	(in)
Slider 15 cart	15	132,76	28/52	1,10/2,04	2	4,41	472	18,58

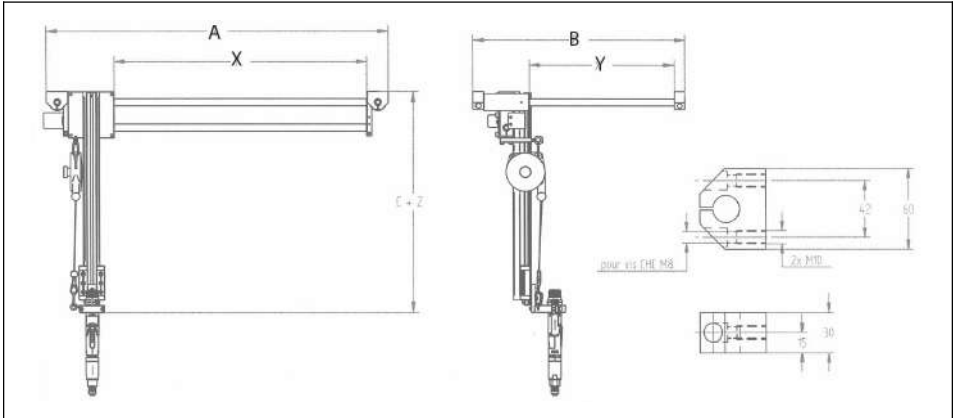

Design.	Horizontal Stroke X Y		External dimension A B		Mini height C (under clamp)	
	(mm)	(in)	(mm)	(in)	(mm)	(in)
Slider 15 cart 300	300 x 410	11,81 x 15,75	514 x 600	22 x 23,62	666	24,45
Slider 15 cart 500	500 x 410	19,68 x 15,75	714 x 600	28 x 23,62		
Slider 15 cart 700	700 x 410	27,56 x 15,75	914 x 600	36 x 23,62		



Warning

Never use torque arms beyond listed torque ratings.

1.5.4 Slider BA / R / PC / RPC

Vertical stroke for Slider BA ...

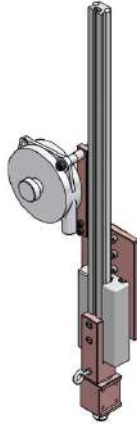

Designation	Torque max		Vert. stroke Z		Max load		Ø Tools min-max	
	(Nm)	(lbf.in)	(mm)	(in)	(kg)	(lbs)	(mm)	(in)
Slider BA12/12R/ Slider BA12PC/12RPC	12	106,21			1,2	2,64	27/50	1,06/ 1,96
Slider BA25/25R/ Slider BA25PC/25RPC	25	221,27	440	17,32	2,2	4,85	28/52	1,10/ 2,04
Slider BA 40/40R/R800 Slider BA 40 PC Slider BA 40 RPC Slider BA 40 RPC/800	40	354,03	640	25,20	3	6,61		
			840	33,07	3	6,61		
					2,5	5,51		
				2,2	4,85			
Slider BA100/100R/ Slider BA100RPC	100	885,07	420	16,53	5	11,02		
			620	24,41				
			820	32,28				



Warning

Never use torque arms beyond listed torque ratings.

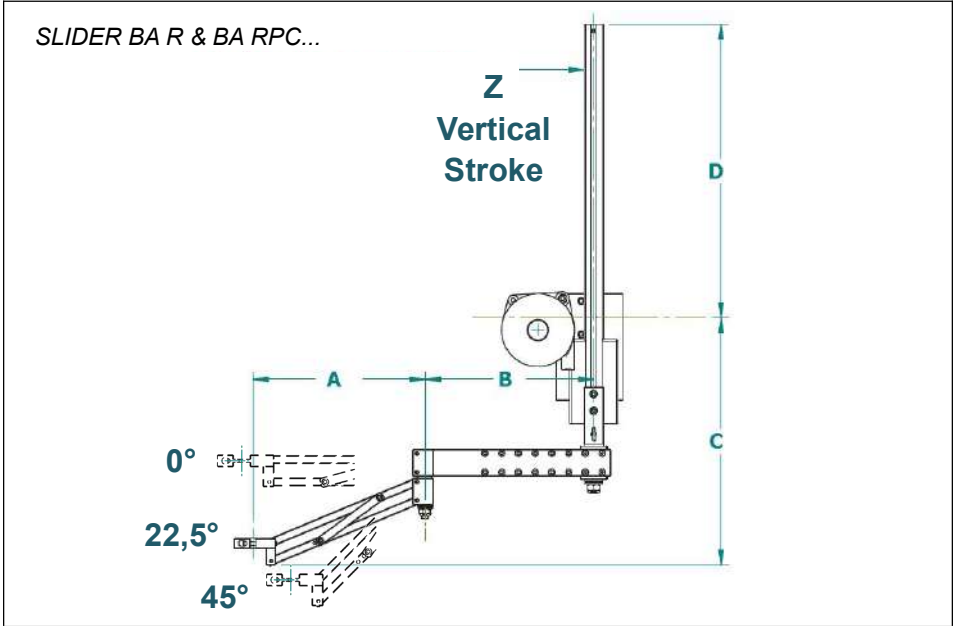

Designation	A (22,5°)		B min-max		Min height C		D (for Z mini)	
	(mm)	(in)	(mm)	(in)	(mm)	(in)	(mm)	(in)
Slider BA 12 R Slider BA 12 RPC	261	10,27	102-252	4,01 - 9,92	370 401	14,57 15,78	439	17,28
Slider BA 25 R Slider BA 25 RPC	278	10,94	95-245	3,74 - 9,64	379 409	14,92 16,10	439 441	17,28 17,36
Slider BA 25 R/600 Slider BA 25 RPC/600	336	13,23	305-330	12,00 - 12,99	403 431	15,87 16,97	439 441	17,28 17,36
Slider BA 40 R Slider BA 40 RPC	387	15,23	150-350	5,90 - 13,78	482 486	18,98 19,13	423	16,65
Slider BA 40 R/800 Slider BA 40 RPC/800	470	18,50	415	16,34	516 495	20,31 19,49		
Slider BA100 R/ Slider BA100 RPC	433	17,05	205-405	8,07 - 15,94	597 577	23,50 22,72	376	14,80
Slider BA100 R/900 Slider BA100 RPC/900	528	20,79	470-520	18,50 - 20,47	634 613	24,96 24,13		

SLIDER BA R & BA RPC...

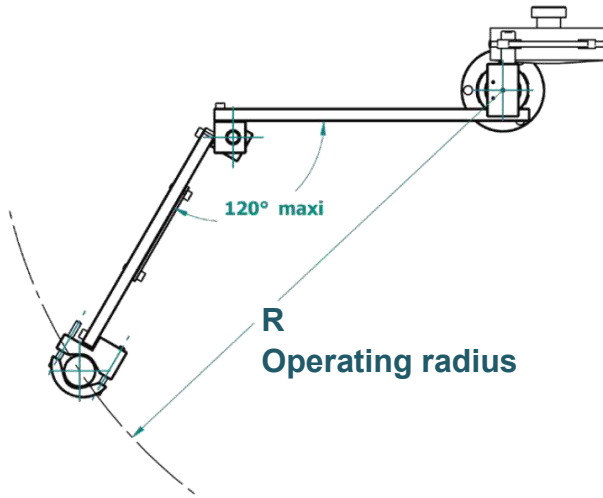

Designation	Operating radius R at 120° with inclination 22,5° and B maxi	
	(mm)	(in)
Slider BA 12 R/RPC	450	17,71
Slider BA 25 R/RPC	460	18,11
Slider BA 25 R/RPC/600	600	23,62
Slider BA 40 R/RPC	650	25,59
Slider BA 40 R/RPC800	800	31,49
Slider BA 100 R/RPC	730	28,74
Slider BA 100 R/RPC/900	900	35,43

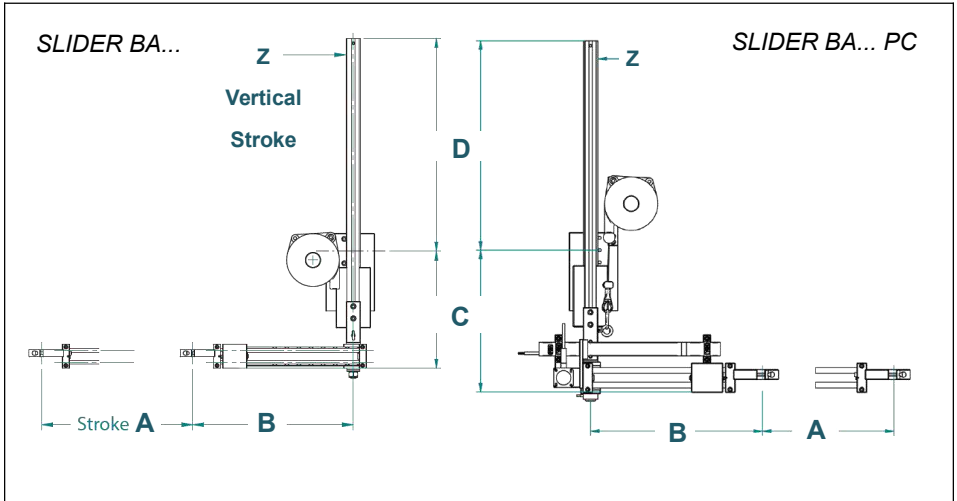

Designation	Stroke A		B min-max		Min height C		D (for Z mini)	
	(mm)	(in)	(mm)	(in)	(mm)	(in)	(mm)	(in)
Slider BA 12	225	8,86	186-336	7,32 - 13,22	242	9,53	409	16,10
Slider BA 12PC	195	7,67			272	10,71	439	17,28
Slider BA 25	250	9,84	221-396	8,70 - 15,59	247	9,72	409	16,10
Slider BA25PC	195	7,67	201-351	7,91 - 13,82	275	10,83	441	17,36
Slider BA 40	295	11,61	260-460	10,23 - 18,11	310	12,20	423	16,65
Slider BA 40PC			320-470	12,59 - 18,50				
Slider BA 100	330	12,99	315-515	12,40 - 20,77	394	15,51	376	14,80

1.5.5 Slider BA mounting plate

Slider BA 12/25

(160 x 100 x 10)

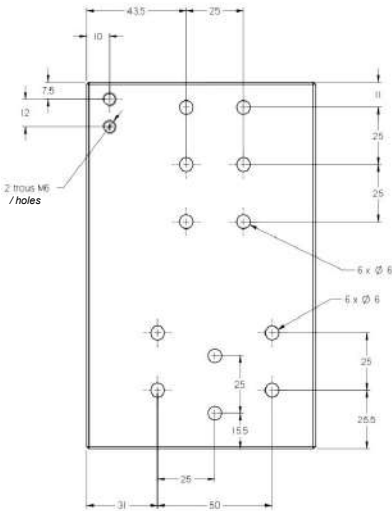

Slider BA 40

(210 x 100 x 10)

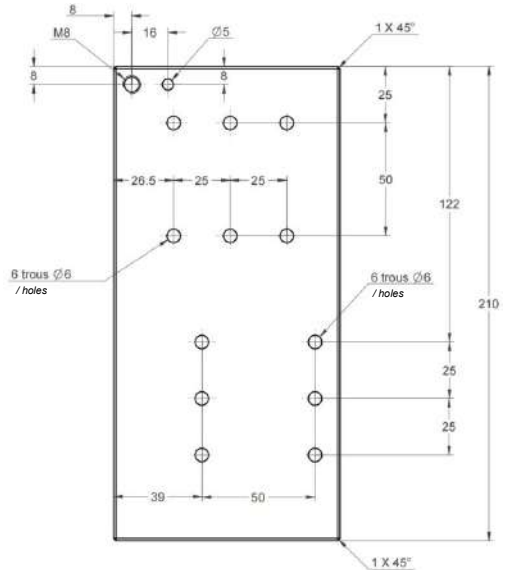

Slider BA 100

(306 x 190 x 15)

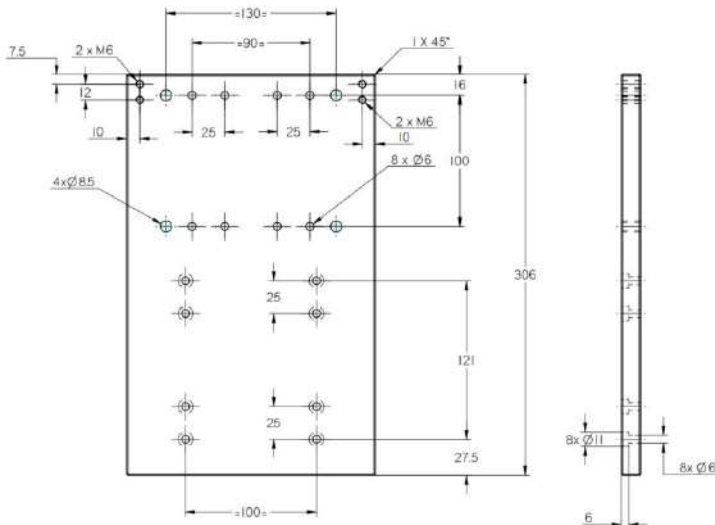

2. STARTING UP

2.1 Workstation description

Torque reaction arm is fixed on a stable frame above a workstation equipped with a tightening tool.



Information

The global stroke must be considered before workstation layout.

2.2 Unpacking

Remove the arm from its packaging.



Information

Before first use, check all the packaging for damage.
Do not use the product if damage is present.



Warning

Danger of suffocation!
Be careful not to leave empty packages lying around.

Dispose of the packaging in accordance with applicable local laws.

2.3 Configuration

The arm is customizable thanks to a wide choice of options and accessories.

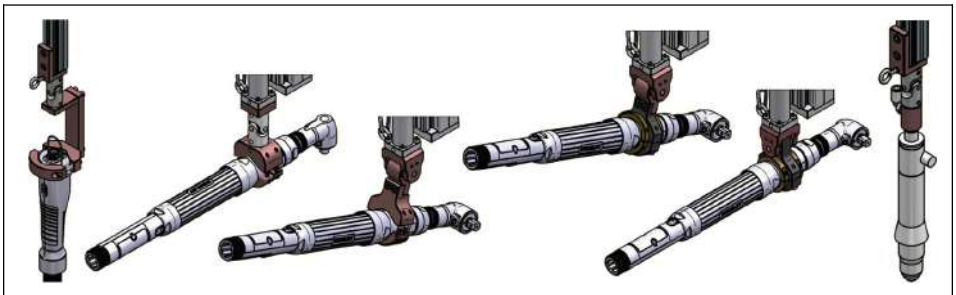

Please refer to our commercial documentation to choose the right accessories.

2.4 Installation



Warning

Protective gloves are recommended while installing torque reaction arms to avoid pinching and cutting hazards.

2.4.1 Standard clamp tool installation

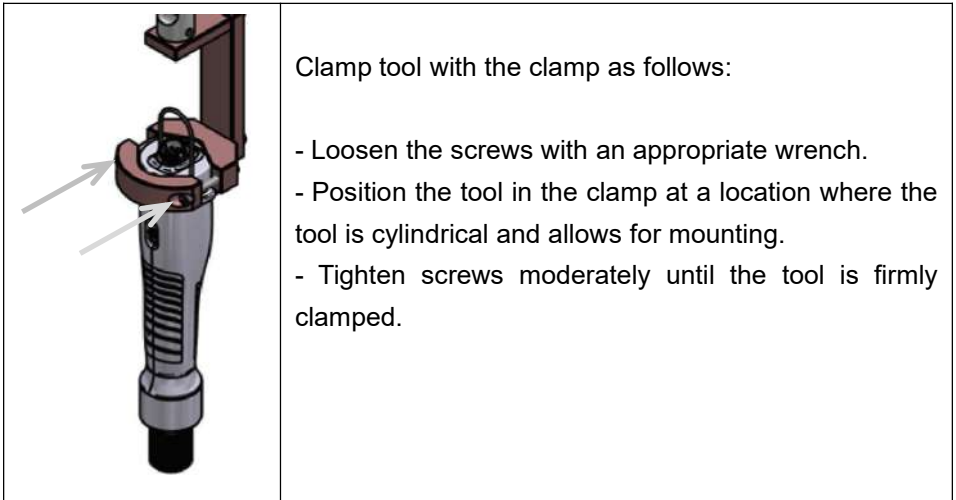

Information

Excessive clamping may affect the operation of the tool mounted on the arm.



Warning

Insufficient clamping will not guarantee the cancellation of the torque reaction effect.

2.4.2 Rotating clamp mounting

Mount the bronze ring on the screwdriver ensuring that the two half-shells are even and flat (A on the plane).

Mount the screwdriver/bronze ring assembly into the clamp, tightened to the maximum.

Then slowly tighten the screws of the bronze ring until it starts to turn.

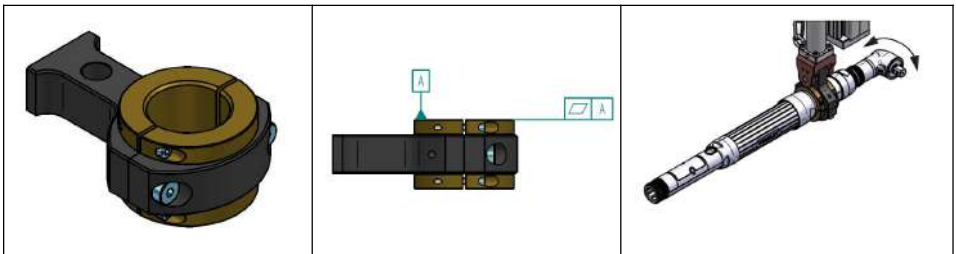

2.4.3 Shift adjustment B min. / B max (SLIDER BA / BA R)

	<p>The primary arm plate installs on the articulated joint.</p> <p>The position is adjustable between limits B min. and B max (see table section 1.5.4)</p> <p>Be careful to avoid damage to encoder cables during adjustment.</p>
--	--

2.4.4 Inclination adjustment (Slider BA R and RPC)

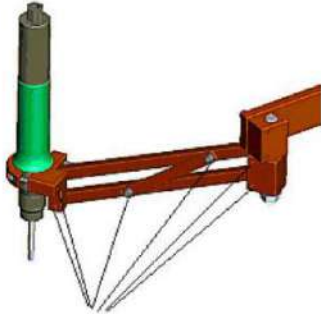
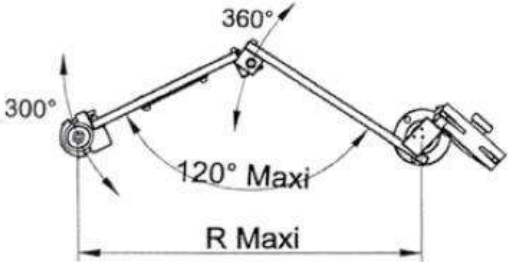
 <p>Inclination adjustment</p>	<p>Adjust the inclination of the forearm (0°, $22,5^\circ$ or 45°) making sure that the angle of the hinge does not exceed 120°.</p> 
---	--

2.4.5 Balancer kit installation

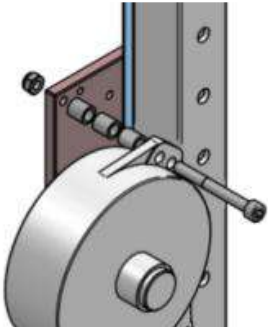
	<p>Install the balancer by firmly tightening the mounting bolt.</p> <p>Use the spacer provided to properly align the balancer. Use of the lock nut allows the balancer to rotation. Make sure the balancer cable is parallel with the arm.</p>
--	--

Warning



Between the balancer and the frame, install the included safety cable to avoid falling. Refer to the dedicated user manual of your balancing model.

2.4.6 Encoders verification (Slider BA PC and RPC series)

For PC models, connect the encoder cable to the encoder junction box. Then connect the DB9 cable from the junction box to the DOGA position control system (DPC Touch V2).

Check that the coverage of the tightening area is within a range of 300 to 3700 points on the Y shaft encoder (rotation):

- Refer to the encoder positioning data provided by the DPC Touch V2 under the «Operation Mode» menu.
- If this is not the case:
 - Loosen the set screws (1). Rotate 180° the encoder (2)
 - Then retighten the set screws.

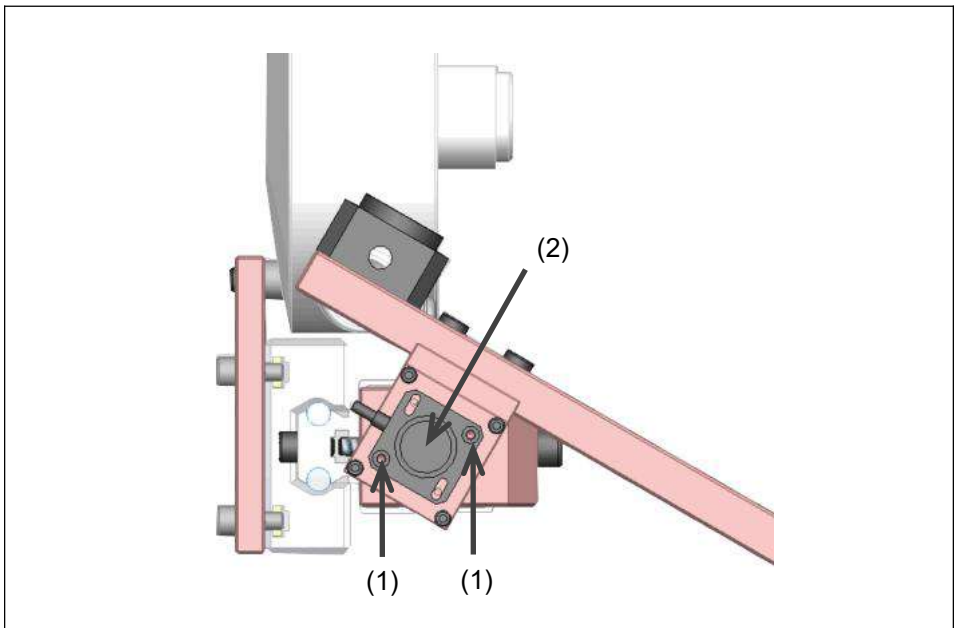

2.4.7 Height adjustment (Slider 8 / 20 Compact)

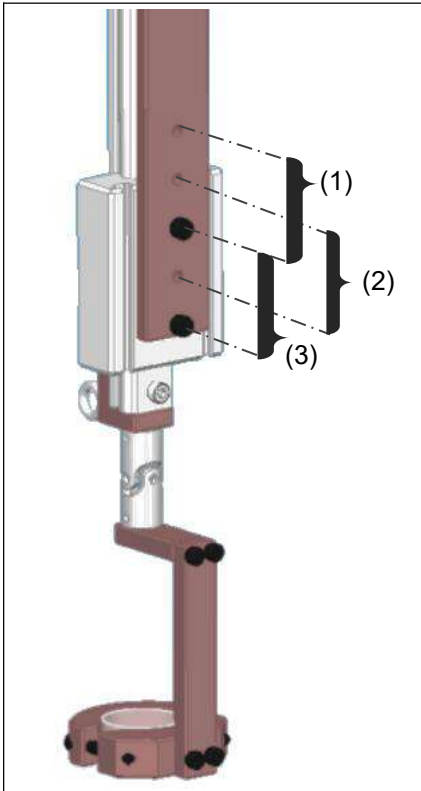

Height (A) can be adjusted between 3 positions.

Loosen the set screws.

Move the trolley up or down.

Then retighten the set screws.

3. SETTINGS

3.1 Balancer setting



It is the effective load at the end of the arm which give the balancer tension. The load is well balanced when the operator can handle the tool easily.

- Decrease the tension by turning the adjuster clockwise.
- Increase the tension by turning the adjuster counterclockwise.



Warning

The cable length must be adjusted appropriately using the rubber ball.



Important

Refer to the information on the body of the balancer.

4. USE



Warning

Protective gloves are recommended while installing torque reaction arms to avoid pinching and cutting hazards.

4.1 Standard use

The arm is fully mechanical and is manually oriented according to the operator's needs.

4.2 Position control use

The arm is fully mechanical and is manually oriented according to the operator's needs.

The position encoders allow for position control.



Information

Refer to the instruction manual of the DPC Touch V2.

5. MAINTENANCE

5.1 Maintenance

5.1.1 General maintenance

Regularly check the rubber ball stop on the balancer and on the longitudinal stroke.

Regularly check the ball bearing carriage and correct the play if needed (according to 5.1.2).

5.1.2 Sliding play adjustment

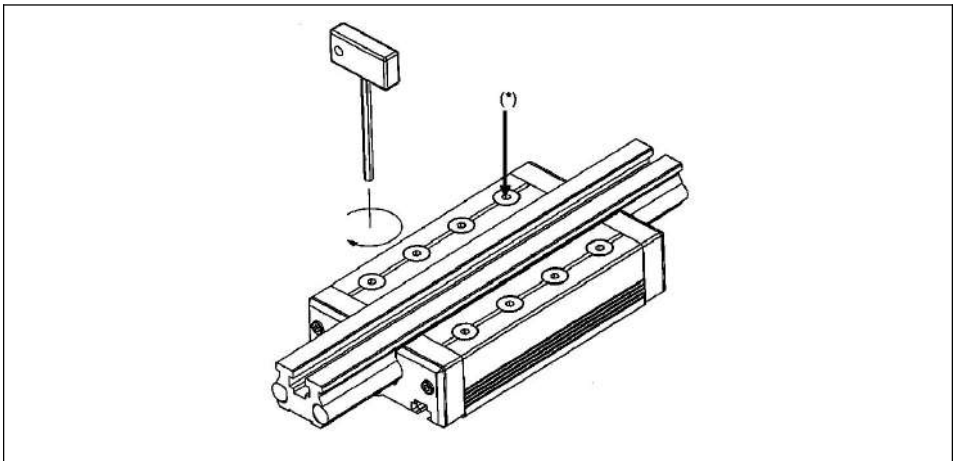

Retighten the roller slide screws in case of play inside the vertical linear guide with the *tool provided.

5.2 Troubleshooting

As part of the production, the proper functioning of the arm has been checked several times. However, if the torque arm malfunctions, check it according to the following list.

Malfunction	Action to take
The arm does not reach the required position	Check the stroke and the distance with respect to the mounting point of the plate. Dismantle and mount the arm closer if necessary.
Encoder signal is not received (PC series)	Check the connection of the encoders to the junction box as well as the DPC Touch V2. Check if the encoder has been damaged. (If so, replace it.)
Angular encoder signal is received but drifting (BA RPC series)	Retighten the pressure screw(s) on the articulation.
Angular encoder signal is received but do not change on a certain angle (BA RPC series)	The blind spot of the encoder is oriented to the working area. Refer to paragraph 2.4.6 to rotate 180° the encoder.
The tool constantly ascends/descends	Check that the weight of the tool is less/more than the capacity of the arm. Refer to paragraph 3.1 for the balancer setting.

If you cannot solve an issue after reading this manual, please contact the DOGA After-Sales Service.



My client area on www.doga.fr

Go to your client area on www.doga.fr, click “Your contacts”, then select your specific **After-sales department contact** depending on the device type.

5.3 Spare parts

For any spare part order, contact your DOGA technical sales representative. Indicate your torque arm part number as well as the specific part to be replaced (refer paragraph 1.4).



My client area on www.doga.fr

Go to your client area on www.doga.fr, click “Your contacts”, then select your specific **After-sales department contact** depending on the device type.

5.4 Phone support

5.4.1 For any questions about using the device



My client area on www.doga.fr

Go to your client area on www.doga.fr, click “Your contacts”, then select your specific **After-sales department contact** depending on the device type.

5.4.2 For any questions about repairs



My client area on www.doga.fr

Go to your client area on www.doga.fr, click “Your contacts”, then select your specific **After-sales department contact** depending on the device type.

If our technician can remotely determine the origin of the fault, he will tell you what to do to allow you to repair it by yourself as far as possible.

5.5 After-sales return

All material must be returned with an after-sales service Return Form, that you must complete and attach to your package.

The repair, maintenance or adjustment service can only start at the receipt of this form.



Information

Following this procedure allows you to quickly take charge of your request and reduce the troubleshooting costs.

DOGA reserves the right to apply a trade-in discount and to invoice, if applicable, the costs of repairing and packaging.

5.5.1 Download the after-sales return form

You can download the return form by following this link:

<http://service.doga.fr/syst/dogatech.nsf/liste/00184>



Information

You can use your own after-sales service return form as long as it contains all the information necessary to take care of your equipment.

5.5.2 Send your equipment

The returned package must be postage paid to the following addresses depending your transport mode:

Postal Packages	Carrier Packages
DOGA - Service SAV 8, avenue Gutenberg - CS 50510 78317 Maurepas Cedex FRANCE	DOGA - Service SAV 11, rue Lavoisier 78310 MAUREPAS FRANCE

5.6 On-site repair

Even though it seems convenient, on-site repair is seldom the best solution for transportable equipment. The conditions in which the technician will work are not as ideal as our workshops and technician travel expenses are costly.

If you require an on-site service, please contact the After-sales department.



My client area on www.doga.fr

Go to your client area on www.doga.fr, click “Your contacts”, then select your specific **After-sales department contact** depending on the device type.

Our services will organize the on-site service.

5.7 Warranty

DOGA guarantees all our products against any defect in parts or fabrication for a period of **12 months**.

To benefit from the parts and labor warranty, the following conditions must be respected:

- The torque reaction arm must have been used in a professional manner and in accordance with the normal conditions of use described in the instruction manual.
- The torque reaction arm must not have suffered any damage from storage, maintenance or improper handling.
- The torque reaction arm must not have been modified or repaired by unqualified persons.

6. SAFETY

6.1 General provisions



The user manual must be carefully stored in a known place and easily accessible to the potential users of the product.



Caution

Read this manual and have each operator read it carefully before installing, using or repairing.

Make absolutely sure that the operator fully understands the rules of use and the meaning of any symbols affixed to the product.

Most accidents could be avoided by following the instruction manual.

These rules have been drafted with reference to the European Directives and their various amendments as well as standard rules product.

In each case, respect and comply the National Safety Standards.

Do not remove or damage the labels and annotations affixed to the product, especially those imposed by the law.

6.2 Residuals risks

6.2.1 Pinching or Cutting Risks

Moving components can cause injuries. Protective gloves are recommended while installing torque reaction arms to avoid pinching and cutting hazards.

6.2.2. Injury Risk

A person hitting the arm with a part of his body (unprotected by safety equipment) exposes himself to the risk of injury.

6.3 Contra-indications

Do not immerse.

Do not expose to splashing liquids.

Do not expose to dusty atmospheres.

Do not oil the arms.

Do not use near to a heat source.

7. STANDARDS

7.1 Manufacturer details

Manufacturer: DOGA

Address: ZA Pariwest
 8 avenue Gutenberg CS 50510
 78317 MAUREPAS CEDEX
 FRANCE

7.2 Markings

SLIDER ...	Designation of equipment
Torque (N)	Max admissible torque
Capacity (kg)	Max admissible load
 <small>8 avenue Gutenberg - CS 50510 78317 Maurepas Cedex - FRANCE</small>	Name and address of the equipment manufacturer
CE	Equipment designed and manufactured in accordance with the requirements of European directives 2006/42/CE.

7.3 Transport and storage



Information

Your equipment can be damaged if you store it or transport it improperly. Observe the transport and storage information for your equipment.

7.3.1 Transport

Use a suitable container to transport the equipment in order to protect it from damage.

7.3.2 Storage

Respect the following guidelines before each storage:

- Disconnect the encoder cable (PC only).
- Clean the arm according to the Maintenance chapter.
- Store it in a suitable container to protect it from dust and direct sunlight.
- Store it in a dry place at an ambient temperature, below 40°C.

7.4 Recycling and end of service life

At the end of service life, torque reaction arms must be sent to suitable recycling programs for ferrous (steel and iron) and non-ferrous (other metal such as aluminium).

8. ANNEXES

8.2 EC Declaration of Conformity

Download the EC Declaration of Conformity by clicking on the link below or by scanning the QR code:

Models	Web link	QR code
Slider Slider BA Slider BA...R Mounting rails	http://service.doga.fr/syst/dogatech.nsf/liste/00106	
Slider BA...PC Slider BA...RPC	http://service.doga.fr/syst/dogatech.nsf/liste/00172	

Download the latest version of this manual
via this link or via QR code:

<http://service.doga.fr/syst/dogatech.nsf/liste/60354>

