



VUE ÉCLATÉE & LISTE DE PIÈCES

OUTILS ÉLECTRIQUES BRUSHLESS - GX-G

DOC.40875-12/21

Cette fiche technique fournit des informations détaillées sur les pièces détachées de votre visseuse.
Référez-vous au sommaire ci-dessous pour identifier votre modèle.

ATTENTION



Utilisez uniquement des pièces d'origine.

Dans le cas contraire, vous risquez de mettre en danger la sécurité de l'opérateur et de détériorer la visseuse.

IMPORTANT

La visseuse en votre possession peut avoir été modifiée pour satisfaire des besoins spécifiques.

Pour être sûr d'obtenir la pièce désirée, nous vous remercions lors de la commande, de bien vouloir préciser le code article de l'outil figurant sur le bon de livraison ou de contacter DOGA au **+33 1 30 66 41 41** en indiquant la date approximative de la livraison.

SOMMAIRE

1. GX et GXT 150, 200 -G (LEVIER) VUE ÉCLATÉE & LISTE DE PIÈCES.....	2
2. GX 150P, 220P - G (POUSSÉE) VUE ÉCLATÉE & LISTE DE PIÈCES.....	6
3. GX & GXT 450 - G (LEVIER) VUE ÉCLATÉE & LISTE DE PIÈCES.....	10
4. GX 450P - G (POUSSÉE) VUE ÉCLATÉE & LISTE DE PIÈCES.....	14
5. GXA 150, 200, 450 - G VUE ÉCLATÉE & LISTE DE PIÈCES.....	18
6. GXS 150, 200 - G (LEVIER) VUE ÉCLATÉE & LISTE DE PIÈCES.....	23
7. GXA 450P - G VUE ÉCLATÉE & LISTE DE PIÈCES.....	27
8. FIRMWARE TABLE.....	32

1. GX et GXT 150, 200 -G (LEVIER) VUE ÉCLATÉE & LISTE DE PIÈCES

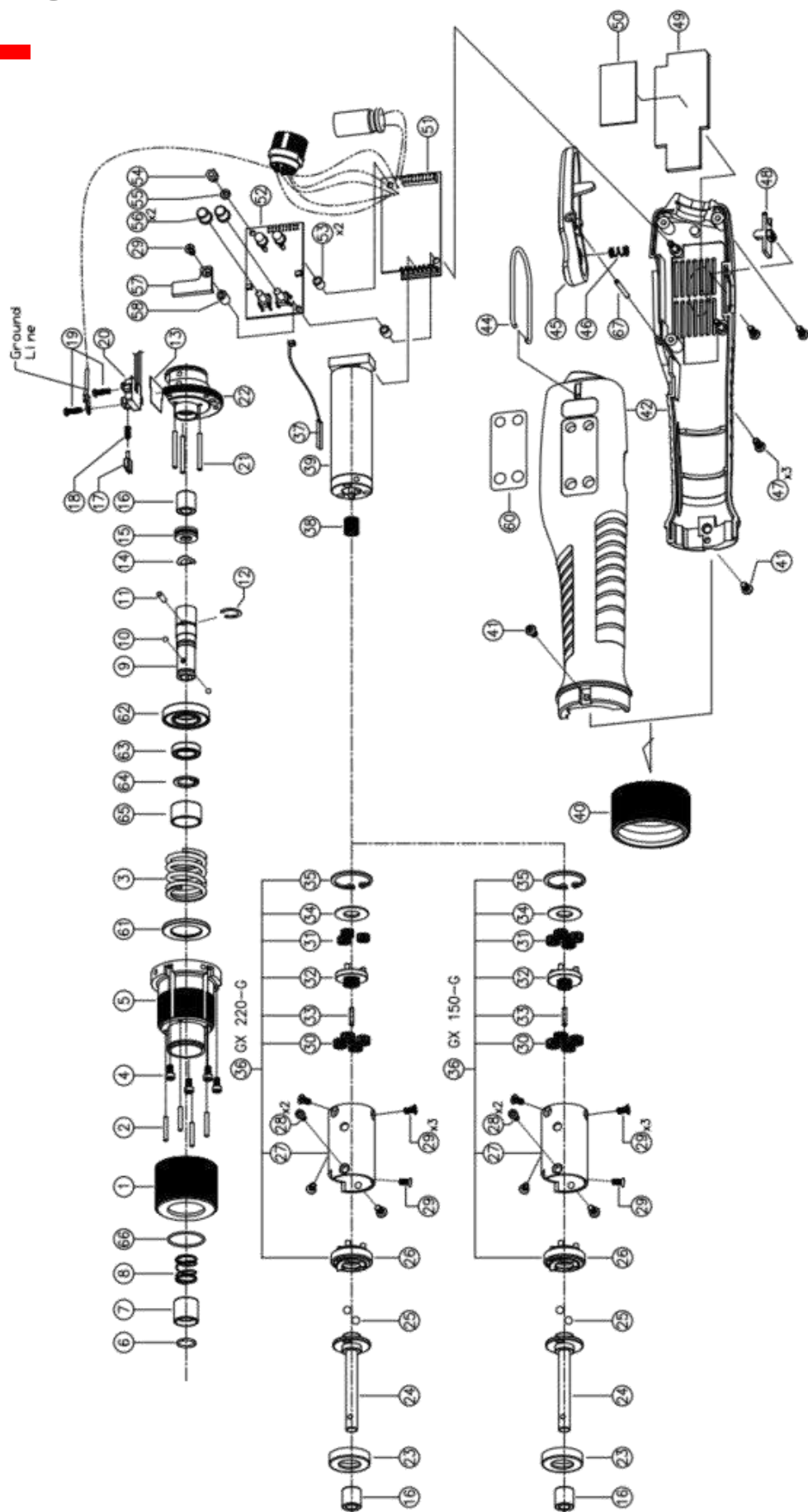

REV.	DATE	DESCRIPTION	검도	승인
△0	2016.10.26	초도작성	-	-
△-1	-	수정내용 확인 안됨	-	-
△A	2018.07.18	도면 양식 업데이트, HOUSING 수정	SHS	SJK
△B	2019.07.05	설계변경으로 인한 17, 20 CODE 변경 42번 HOUSING ASSY 추가, 반제품 CODE 추가	-	SJK

Rep	Code DOGA	Ancienne Ref.	Nouvelle Ref.	Description	GX150-A/ GXT150-A	GX220-A/ GXT220-A
1	4-1070300	5000888	505-0002	BAGUE DE REGLAGE DE COUPLE	1	1
2	4-1070301	5000899	557-0003	GOUPILLE (AJUSTEMENT)	4	4
3	4-1070335	5000942	581-0065	RESSORT (COUPLE)	1	
3	4-1070336	5000943	581-0067	RESSORT (COUPLE)		1
4	4-1075080	PSW2201	515-0008	VIS	4	4
5	4-1077679	3000989	316-0024	ENCEINTE EMBRAYAGE	1	1
6	4-1075005	PAL1973	527-0017	ANNEAU EN C (DOUILLE EMBOUT)	1	1
7	4-1070304	5000892	524-0003	BAGUE	1	1
8	4-1070305	5000902	581-0025	RESSORT (BAGUE)	1	1
9	4-1070306	5000890	514-0010	DOUILLE EMBOUT (A)	1	1
9	4-1070307	5000891	514-0021	DOUILLE EMBOUT (B)		
10	4-1075014	PAL1928	507-0003	BILLE	2	2
10	4-1090109	PAL1929	507-0002	BILLE		
11	4-1077135	PAL1231	557-0017	PION (PORTE SATELLITE)	1	1
12	4-1075018	PSK1954	527-0006	ANNEAU EN C	1	1
13		-	548-0177	ETIQUETTE BRIDE SUPPORT	1	1
14	4-1070310	5000887	590-0032	RONDELLE (CONIQUE)	1	1
15	4-1090119	PSK1921	509-0035	ROULEMENT (SECONDAIRE)	1	1
16	4-1002754	5000077	509-0028	ROULEMENT (SANS HUILE)	2	2
17	4-1090199	-	349-0003	ENSEMBLE COULISSANT	1	1
18	4-1002749	5000064	581-0043	RESSORT (LIMITE)	1	1
19	4-1075114	PSW2211	571-0012	VIS	2	2
20	4-1090195	-	346-0020	ENSEMBLE CAPTEUR (LEVIER)	1	1
21	4-1070338	5000900	557-0028	AIGUILLE	3	3
22	4-1002762	3000079	304-0008	BRIDE SUPPORT (LEVIER)	1	1
23	4-1090115	PFF1319	569-0011	ANNEAU COULISSANT	1	1
24	4-1002750	5000066	573-0001	ARBRE (LEVIER)	1	1
25	4-1075106	PAL1932	507-0005	BILLE	2	2
26	4-1002708	3000268	311-0017	ENSEMBLE EMBRAYAGE	1	
26	4-1077680	3000269	311-0019	ENSEMBLE EMBRAYAGE		1
27	4-1002796	5000491	536-0046	CARTER ENGRENAGE		1
27	4-1090108	PFE1201A	536-0048	CARTER ENGRENAGE	1	

Rep	Code DOGA	Ancienne Ref.	Nouvelle Ref.	Description	GX150-A/ GXT150-A	GX220-A/ GXT220-A
28	4-1075008	PSW2204	515-0009	VIS	2	2
29	4-1002835	5000665	571-0001	VIS (FL TORX)	5	5
30	4-1002751	5000067	536-0028	PIGNON (2EM ETAGE)	4	
30	4-1075118	PFE1212	536-0024	PIGNON (2EM ETAGE B)		4
31	4-1002751	5000067	536-0028	PIGNON (2EM ETAGE)	4	
31	4-1002758	5000134	536-0018	SATELLITE (1ER ETAGE)		3
32	4-1002850	PFE1102	325-0009	PORTE SATELLITE	1	
32	4-1075123	PFE1103	325-0012	PORTE SATELLITE		1
33	4-1090113	PFE1915	557-0007	GOUPILLE (CENTRAGE)	1	1
34	4-1090114	PFE1947	590-0005	RONDELLE	1	1
35	4-1075125	PFE1903	578-0004	ANNEAU DE SERRAGE	1	1
36		-	330-0081	BOITIER D'ENGRENAGE	1	
36		-	330-0082	BOITIER D'ENGRENAGE		1
37	4-1000944	3000623	353-0001	ENSEMBLE THERMISTANCE	1	1
38	4-1090111	PFE1235	536-0094	ENGRENAGE (PIGNON)	1	
38	4-1075127	PFE1236	536-0088	ENGRENAGE (PIGNON B)		1
39	4-1000938	3000561	330-0005	ENSEMBLE MOTEUR	1	1
40	4-1070339	5000893	544-0020	BAGUE DE MAINTIEN COQUE	1	1
41	4-1002753	5000072	571-0016	VIS	2	2
42		3000912	903-0048	KIT COQUE TYPE NF POUR GX40V	1	1
44	4-1070143	PAL1803	541-0003	CROCHET	1	1
45	4-1002705	3000160	329-0014	ENSEMBLE LEVIER	1	1
46	4-1090112	PFE1841	581-0037	RESSORT (LEVIER)	1	1
47	4-1077172	PSW2602	571-0025	VIS	3	3
48	4-1012329	PFF1130	316-0012	INTERRUPTEUR DE REVERSIBILITE	1	1
49	4-1070145	5000135	539-0005	DIFFUSEUR DE CHALEUR	1	1
50	4-1002759	5000143	903-0067	COUSSINET SILICONE THERMIQUE	1	1
51	4-1077684	3000161	331-0012	KIT CARTE D'ALIMENTATION	1	1
52	4-1050632	3000270	332-0062	KIT CARTE ELECTRONIQUE DE COMMANDE <i>*Nota : Firmware non inclus (voir page 32)</i>	1	1
53	4-1002843	PFF1842A	582-0016	SUPPORT (PCB)	2	2
54	4-1090116	PFF1824	555-0001	ECROU	1	1
55	4-1002878	PSW2803	590-0021	RONDELLE	1	1

Rep	Code DOGA	Ancienne Ref.	Nouvelle Ref.	Description	GX150-A/ GXT150-A	GX220-A/ GXT220-A
56	4-1070148	5000070	520-0005	BOUCHON	2	2
57	4-1012345	PFF1719	526-0020	COUVERCLE (VERROUILLAGE CONNECTEUR)	1	1
58	4-1078885	PFF1824A	555-0002	ECROU	1	1
60	4-1070151	5000659	548-0114	ETIQUETTE (FENETRE)	1	1
60	4-1070152	5000660	548-0115	ETIQUETTE (FENETRE)	1	1
60	4-1070153	5000661	548-0116	ETIQUETTE (FENETRE)	1	1
61	4-1070316	5000898	582-0035	SUPPORT (COUPLE RESSORT RONDELLE)	1	1
62	4-1070332	-	582-0044	SUPPORT (COUPLE RESSORT)	1	1
63	4-1070318	5001022	509-0022	ROULEMENT (BILLE)	1	1
64	4-1070319	5001026	579-0013	ANNEAU DE SERRAGE	1	1
65	4-1070320	5000889	510-0001	PORTE-ROULEMENT	1	1
66	4-1070321	5000904	527-0023	ANNEAU EN C (STOP)	1	1
67	4-1090118	PSK1327	557-0032	AIGUILLE	1	1

2. GX 150P, 220P - G (POUSSÉE) VUE ÉCLATÉE & LISTE DE PIÈCES

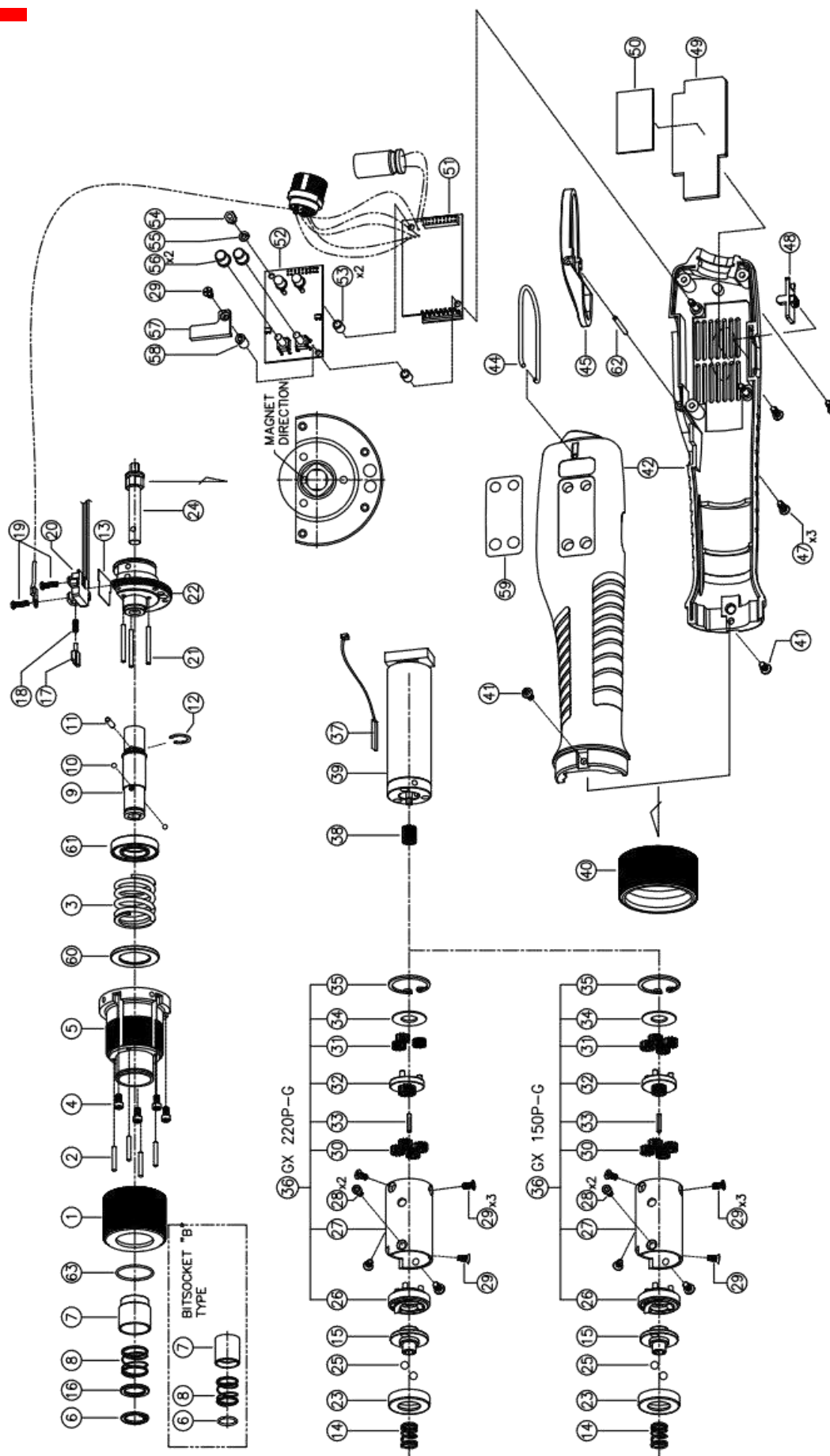

REV.	DATE	DESCRIPTION	검도	승인
△0	2016.10.27	초도작성	-	-
△-A	-	수정내용 확인 안됨	-	-
△5	2018.07.18	도면 양식 업데이트, HOUSING 수정 설계변경으로 인한 17, 20 CODE 변경	SHS	SJK
△6	2019.07.05	42번 HOUSING ASSY 추가, 변경용 CODE 추가	-	SJK

Rep	Code DOGA	Ancienne Ref.	Nouvelle Ref.	Description	GX150P-A	GX220P-A
1	4-1070300	5000888	505-0002	BAGUE DE REGLAGE DE COUPLE	1	1
2	4-1070301	5000899	557-0003	GOUPILLE (AJUSTEMENT)	4	4
3	4-1070335	5000942	581-0065	RESSORT (COUPLE)	1	
3	4-1070336	5000943	581-0067	RESSORT (COUPLE)		1
4	4-1075080	PSW2201	515-0008	VIS	4	4
5	4-1070324	3000949	316-0023	ENCEINTE EMBRAYAGE	1	1
6	4-1070325	5000945	579-0002	ANNEAU DE SERRAGE	1	1
7	4-1070326	5000912	524-0007	BAGUE (A)	1	1
8	4-1070328	5000903	581-0026	RESSORT (BAGUE)	1	1
9	4-1070329	5000909	514-0009	DOUILLE EMBOUT (A)	1	1
10	4-1090109	PAL1929	507-0002	BILLE	2	2
11	4-1077135	PAL1231	557-0017	PION (PORTE SATELLITE)	1	1
12	4-1075018	PSK1954	527-0006	ANNEAU EN C	1	1
13		-	548-0177	ETIQUETTE BRIDE SUPPORT	1	1
14	4-1002755	5000078	581-0045	RESSORT (POUSSEE)	1	1
15	4-1002756	5000079	573-0002	ARBRE (B)	1	1
16	4-1070341	5000914	582-0006	SUPPORT (BAGUE RESSORT)	1	1
17	4-1090199	-	349-0003	ENSEMBLE COULISSANT	1	1
18	4-1002749	5000064	581-0043	RESSORT (LIMITE)	1	1
19	4-1075114	PSW2211	571-0012	VIS	2	2
20	4-1090196	-	346-0021	ENSEMBLE CAPTEUR (POUSSEE)	1	1
21	4-1070338	5000900	557-0028	AIGUILLE	3	3
22	4-1032000	3000087	304-0010	BRIDE SUPPORT (POUSSEE)	1	1
23	4-1090115	PFF1319	569-0011	ANNEAU COULISSANT	1	1
24	4-1032001	3000619	347-0014	ENSEMBLE ARBRE (POUSSEE)	1	1
25	4-1075106	PAL1932	507-0005	BILLE	2	2
26	4-1002708	3000268	311-0017	ENSEMBLE EMBRAYAGE	1	
26	4-1077680	3000269	311-0019	ENSEMBLE EMBRAYAGE		1
27	4-1002796	5000491	536-0046	CARTER ENGRENAGE		1
27	4-1090108	PFE1201A	536-0048	CARTER ENGRENAGE	1	
28	4-1075008	PSW2204	515-0009	VIS	2	2
29	4-1002835	5000665	571-0001	VIS (FL TORX)	5	5

Rep	Code DOGA	Ancienne Ref.	Nouvelle Ref.	Description	GX150P-A	GX220P-A
30	4-1002751	5000067	536-0028	PIGNON (2EME ETAGE)	4	
30	4-1075118	PFE1212	536-0024	PIGNON (2EME ETAGE B)		4
31	4-1002751	5000067	536-0028	PIGNON (2EME ETAGE)	4	
31	4-1002758	5000134	536-0018	SATELLITE (1ER ETAGE)		3
32	4-1002850	PFE1102	325-0009	PORTE SATELLITE	1	
32	4-1075123	PFE1103	325-0012	PORTE SATELLITE		1
33	4-1090113	PFE1915	557-0007	GOUPILLE (CENTRAGE)	1	1
34	4-1090114	PFE1947	590-0005	RONDELLE	1	1
35	4-1075125	PFE1903	578-0004	ANNEAU DE SERRAGE	1	1
36		-	330-0081	BOITIER D'ENGRENAGE	1	
36		-	330-0082	BOITIER D'ENGRENAGE		1
37	4-1000944	3000623	353-0001	ENSEMBLE THERMISTANCE	1	1
38	4-1090111	PFE1235	536-0094	ENGRENAGE (PIGNON)	1	
38	4-1075127	PFE1236	536-0088	ENGRENAGE (PIGNON B)		1
39	4-1000938	3000561	330-0005	ENSEMBLE MOTEUR	1	1
40	4-1070339	5000893	544-0020	BAGUE DE MAINTIEN COQUE	1	1
41	4-1002753	5000072	571-0016	VIS	2	2
42		3000912	903-0048	KIT COQUE TYPE NF POUR GX40V	1	1
44	4-1070143	PAL1803	541-0003	CROCHET	1	1
45	4-1070167	5000144	506-0012	FIXATION	1	1
47	4-1077172	PSW2602	571-0025	VIS	3	3
48	4-1012329	PFF1130	316-0012	INTERRUPTEUR DE REVERSIBILITE	1	1
49	4-1070145	5000135	539-0005	DIFFUSEUR DE CHALEUR	1	1
50	4-1002759	5000143	903-0067	COUSSINET SILICONE THERMIQUE	1	1
51	4-1077684	3000161	331-0012	KIT CARTE D'ALIMENTATION	1	1
52	4-1050631	3000162	332-0065	KIT CARTE ELECTRONIQUE DE COMMANDE <i>*Nota : Firmware non inclus (voir page 32)</i>	1	1
53	4-1002843	PFF1842A	582-0016	SUPPORT (PCB)	2	2
54	4-1090116	PFF1824	555-0001	ECROU	1	1
55	4-1002878	PSW2803	590-0021	RONDELLE	1	1
56	4-1070148	5000070	520-0005	BOUCHON	2	2
57	4-1012345	PFF1719	526-0020	COUVERCLE (VERROUILLAGE CONNECTEUR)	1	1
58	4-1078885	PFF1824A	555-0002	ECROU	1	1

Rep	Code DOGA	Ancienne Ref.	Nouvelle Ref.	Description	GX150P-A	GX220P-A
59	4-1070151	5000659	548-0114	ETIQUETTE (FENETRE)	1	1
59	4-1070152	5000660	548-0115	ETIQUETTE (FENETRE)	1	1
60	4-1070316	5000898	582-0035	SUPPORT (RONDELLE RESSORT COUPLE)	1	1
61	4-1070332	-	582-0044	SUPPORT (RESSORT COUPLE)	1	1
62	4-1090118	PSK1327	557-0032	AIGUILLE	1	1
63	4-1070321	5000904	527-0023	ANNEAU EN C (STOP)	1	1

3. GX & GXT 450 - G (LEVIER) VUE ÉCLATÉE & LISTE DE PIÈCES

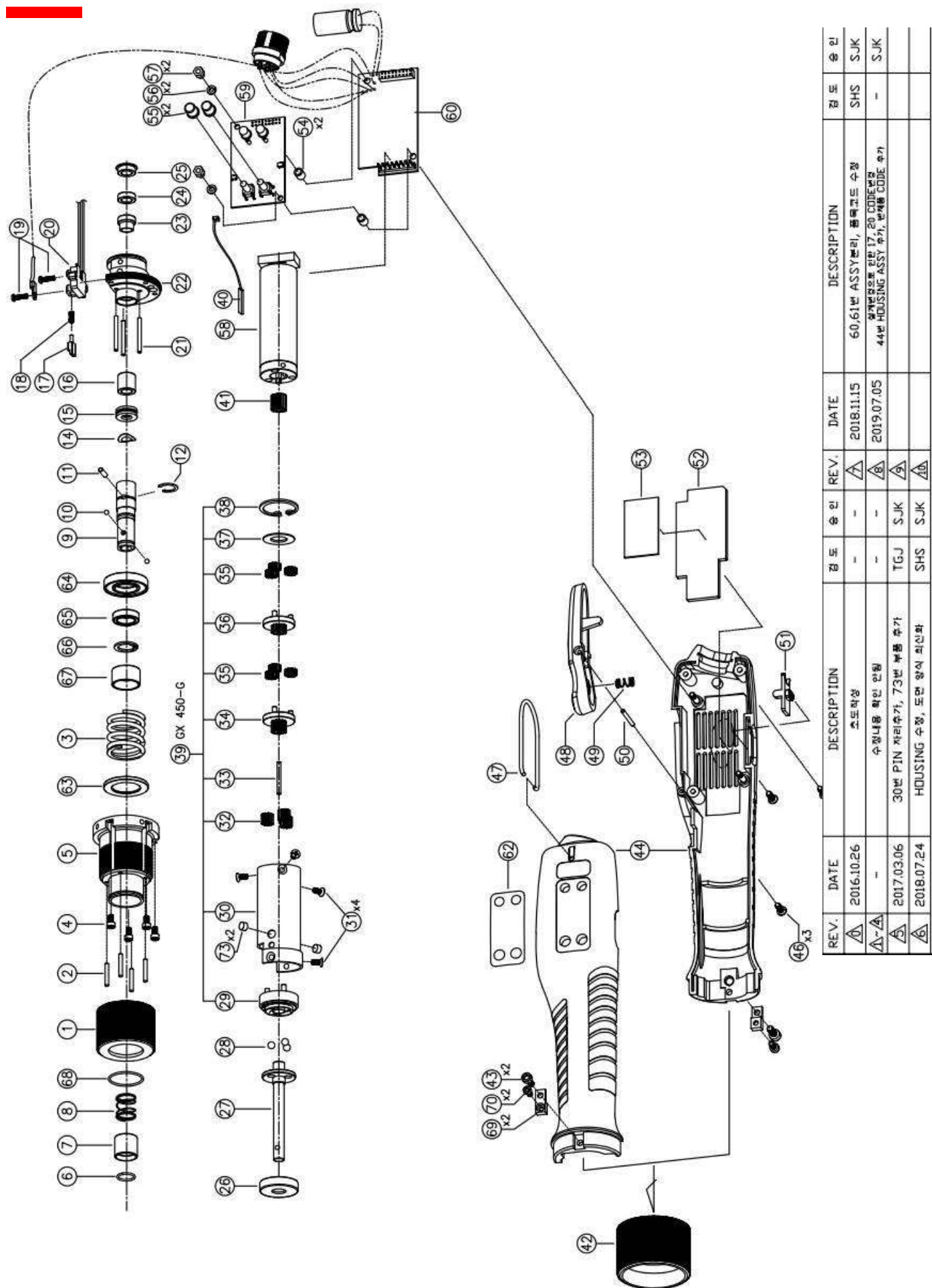

Rep	Code DOGA	Ancienne Ref.	Nouvelle Ref.	Description	GX450-A/ GXT450-A
1	4-1070300	5000888	505-0002	BAGUE DE REGLAGE DE COUPLE	1
2	4-1070301	5000899	557-0003	GOUPILLE (AJUSTEMENT)	4
3	4-1070302	5000944	581-0069	RESSORT (COUPLE)	1
4	4-1075008	PSW2204	515-0009	VIS	4
5	4-1077679	3000989	316-0024	ENCEINTE EMBRAYAGE	1
6	4-1075005	PAL1973	527-0017	ANNEAU EN C (DOUILLE EMBOUT)	1
7	4-1070304	5000892	524-0003	BAGUE	1
8	4-1070305	5000902	581-0025	RESSORT (BAGUE)	1
9	4-1070306	5000890	514-0010	DOUILLE EMBOUT (A)	1
10	4-1075014	PAL1928	507-0003	BILLE	2
11	4-1077135	PAL1231	557-0017	PION (PORTE SATELLITE)	1
12	4-1075018	PSK1954	527-0006	ANNEAU EN C	1
13		-	548-0177	ETIQUETTE BRIDE SUPPORT	1
14	4-1070310	5000887	590-0032	RONDELLE (CONIQUE)	1
15	4-1090119	PSK1921	509-0035	ROULEMENT (SECONDAIRE)	1
16	4-1002754	5000077	509-0028	ROULEMENT (SANS HUILE)	1
17	4-1090199	-	349-0003	ENSEMBLE COULISSANT	1
18	4-1002749	5000064	581-0043	RESSORT (LIMITE)	1
19	4-1075114	PSW2211	571-0012	VIS	2
20	4-1090195	-	346-0020	ENSEMBLE CAPTEUR (LEVIER)	1
21	4-1070311	5000901	557-0029	AIGUILLE	3
22	4-1077510	3000171	304-0014	BRIDE SUPPORT (LEVIER)	1
23	4-1090077	5000297	582-0002	SUPPORT (ROULEMENT)	1
24	4-1002783	5000376	509-0001	ROULEMENT (BILLE)	1
25	4-1002784	5000377	509-0002	ROULEMENT (BILLE)	1

Rep	Code DOGA	Ancienne Ref.	Nouvelle Ref.	Description	GX450-A/ GXT450-A
26	4-1075103	PFE1319	569-0010	ANNEAU COULISSANT	1
27	4-1070188	5000084	573-0003	ARBRE (LEVIER)	1
28	4-1070206	5000300	507-0004	BILLE	3
29	4-1070313	3000893	311-0016	ENSEMBLE EMBRAYAGE	1
30	4-1055332	5000147	536-0058	CARTER ENGRENAGE	1
31	4-1002835	5000665	571-0001	VIS (FL TORX)	4
32	4-1055333	5000009	536-0039	PIGNON (3EME ETAGE)	3
33	4-1090118	PSK1327	557-0032	AIGUILLE	1
34	4-1055334	3000170	325-0016	PORTE SATELLITE	1
35	4-1055335	5000008	536-0009	ENGRENAGE (SATELLITE)	6
36	4-1002707	3000175	325-0007	PORTE SATELLITE	1
37	4-1090114	PFE1947	590-0005	RONDELLE	1
38	4-1075125	PFE1903	578-0004	ANNEAU DE SERRAGE	1
39		-	330-0084	BOITIER D'ENGRENAGE	1
40	4-1000944	3000623	353-0001	ENSEMBLE THERMISTANCE	1
41	4-1002745	5000027	536-0075	ENGRENAGE (PIGNON MOTEUR)	1
42	4-1070314	5000894	544-0022	BAGUE DE MAINTIEN COQUE	1
43	4-1002752	5000069	515-0003	VIS	2
44		3000912	903-0048	KIT COQUE TYPE NF POUR GX40V	1
46	4-1077172	PSW2602	571-0025	VIS	3
47	4-1070143	PAL1803	541-0003	CROCHET	1
48	4-1002705	3000160	329-0014	ENSEMBLE LEVIER	1
49	4-1090112	PFE1841	581-0037	RESSORT (LEVIER)	1
50	4-1090118	PSK1327	557-0032	AIGUILLE	1
51	4-1012329	PFF1130	316-0012	INTERRUPTEUR DE REVERSIBILITE	1

Rep	Code DOGA	Ancienne Ref.	Nouvelle Ref.	Description	GX450-A/ GXT450-A
52	4-1070145	5000135	539-0005	DIFFUSEUR DE CHALEUR	1
53	4-1002759	5000143	903-0067	COUSSINET SILICONE THERMIQUE	1
54	4-1002843	PFF1842A	582-0016	SUPPORT (PCB)	2
55	4-1070148	5000070	520-0005	BOUCHON	2
56	4-1002878	PSW2803	590-0021	RONDELLE	2
57	4-1090116	PFF1824	555-0001	ECROU	2
58	4-1000938	3000561	330-0005	ENSEMBLE MOTEUR	1
59	4-1050632	3000270	332-0062	KIT CARTE ELECTRONIQUE DE COMMANDE <i>*Nota : Firmware non inclus (voir page 32)</i>	1
60	4-1077684	3000161	331-0012	KIT CARTE D'ALIMENTATION	1
62	4-1070151	5000659	548-0114	ETIQUETTE (FENETRE)	1
62	4-1070152	5000660	548-0115	ETIQUETTE (FENETRE)	1
62	4-1070153	5000661	548-0116	ETIQUETTE (FENETRE)	1
63	4-1070316	5000898	582-0035	SUPPORT (COUPLE RESSORT RONDELLE)	1
64	4-1070332	-	582-0044	SUPPORT (RESSORT COUPLE)	1
65	4-1070318	5001022	509-0022	ROULEMENT (BILLE)	1
66	4-1070319	5001026	579-0013	ANNEAU DE SERRAGE	1
67	4-1070320	5000889	510-0001	PORTE-ROULEMENT	1
68	4-1070321	5000904	527-0023	ANNEAU EN C (STOP)	1
69	4-1070322	5001027	547-0003	VIS	2
70	4-1070323	5001028	515-0024	VIS	2
73	4-1000920	-	557-0044	GOUPILLE (FIXE)	1

4. GX 450P - G (POUSSÉE) VUE ÉCLATÉE & LISTE DE PIÈCES

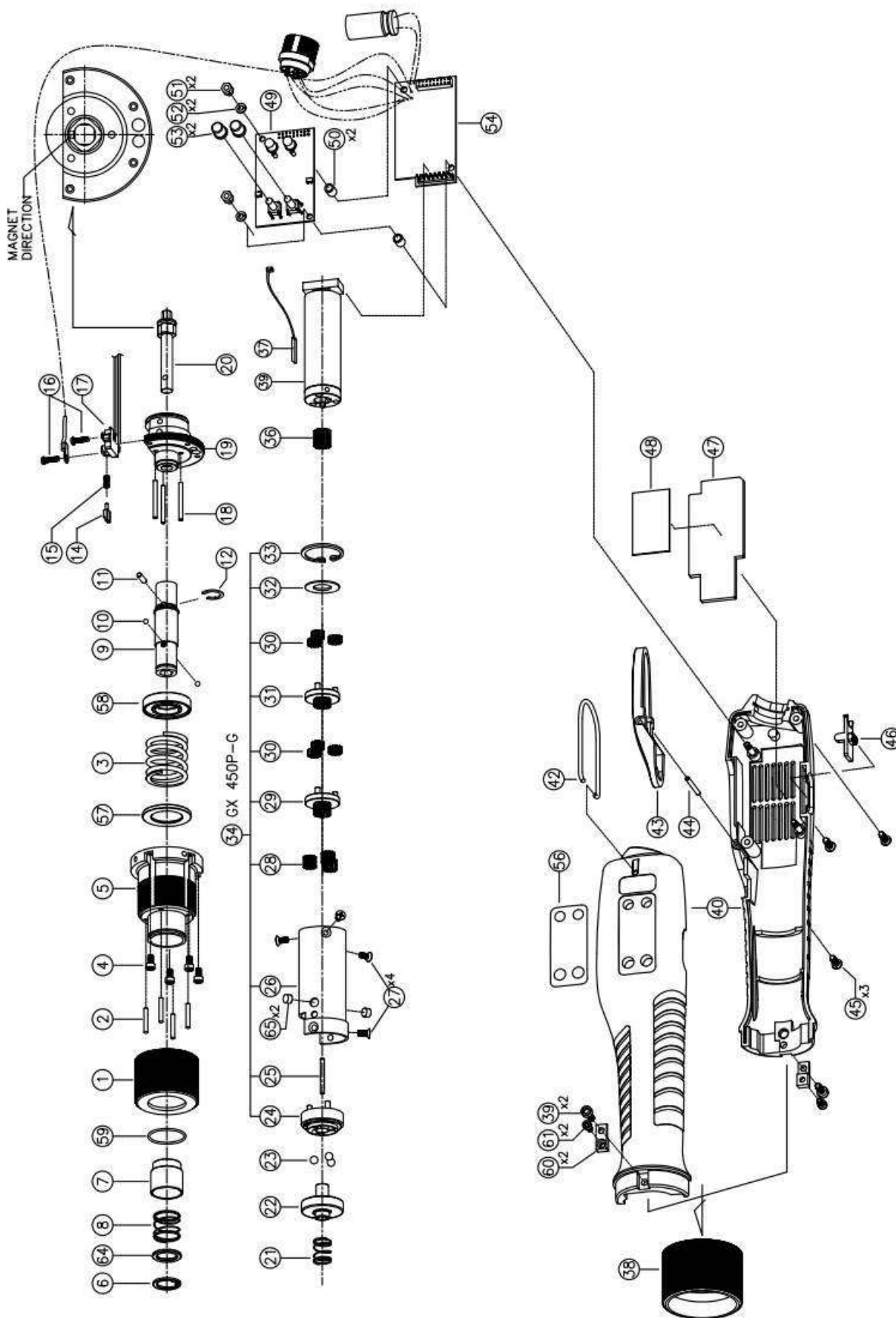

REV.	DATE	DESCRIPTION	검토 승인	DATE	DESCRIPTION	검토 승인
△	2016.10.26	초도작성	-	2018.11.15	54,55번 ASSY에M 분리, 품목코드 수정	SHS SJK
△-△	-	수정내용 확인 인칭	-	2019.07.05	상기변경으로 인한 14,17 CODE변경 40번 HOUSING ASSY 추가, 판매용 CODE 추가	- SJK
△	2017.03.06	26번 PIN 재리수기, 6.5번 부품 추가	JTG SJK			
△	2018.07.27	도면 형식 업데이트, HOUSING 수정	SHS SJK			

Rep	Code DOGA	Ancienne Ref.	Nouvelle Ref.	Description	GX450P-A
1	4-1070300	5000888	505-0002	BAGUE DE REGLAGE DE COUPLE	1
2	4-1070301	5000899	557-0003	GOUPILLE (AJUSTEMENT)	4
3	4-1070302	5000944	581-0069	RESSORT (COUPLE)	1
4	4-1075008	PSW2204	515-0009	VIS	4
5	4-1070324	3000949	316-0023	ENCEINTE EMBRAYAGE	1
6	4-1070325	5000945	579-0002	ANNEAU DE SERRAGE	1
7	4-1070326	5000912	524-0007	BAGUE (A)	1
8	4-1070328	5000903	581-0026	RESSORT (BAGUE)	1
9	4-1070329	5000909	514-0009	DOUILLE EMBOUT (A)	1
10	4-1090109	PAL1929	507-0002	BILLE	2
11	4-1077135	PAL1231	557-0017	PION (PORTE SATELLITE)	1
12	4-1075018	PSK1954	527-0006	ANNEAU EN C	1
13		-	548-0177	ETIQUETTE BRIDE SUPPORT	1
14	4-1090199	-	349-0003	ENSEMBLE COULISSANT	1
15	4-1002749	5000064	581-0043	RESSORT (LIMITE)	1
16	4-1075114	PSW2211	571-0012	VIS	2
17	4-1090196	-	346-0021	ENSEMBLE CAPTEUR (POUSSEE)	1
18	4-1070311	5000901	557-0029	AIGUILLE	3
19	4-1012407	3000172	304-0012	BRIDE SUPPORT (POUSSEE)	1
20	4-1032001	3000619	347-0014	ENSEMBLE ARBRE (POUSSEE)	1
21	4-1070204	5000299	581-0047	RESSORT (POUSSEE)	1
22	4-1070205	3000280	347-0016	ENSEMBLE ARBRE (B)	1
23	4-1070206	5000300	507-0004	BILLE	3
24	4-1012505	-	311-0030	ENSEMBLE EMBRAYAGE	1
25	4-1090118	PSK1327	557-0032	AIGUILLE	1

Rep	Code DOGA	Ancienne Ref.	Nouvelle Ref.	Description	GX450P-A
26	4-1055332	5000147	536-0058	CARTER ENGRENAGE	1
27	4-1002835	5000665	571-0001	VIS (FL TORX)	4
28	4-1055333	5000009	536-0039	PIGNON (3EME ETAGE)	3
29	4-1055334	3000170	325-0016	PORTE SATELLITE	1
30	4-1055335	5000008	536-0009	ENGRENAGE (SATELLITE)	6
31	4-1002707	3000175	325-0007	PORTE SATELLITE	1
32	4-1090114	PFE1947	590-0005	RONDELLE	1
33	4-1075125	PFE1903	578-0004	ANNEAU DE SERRAGE	1
34		-	330-0086	BOITIER D'ENGRENAGE	1
35	4-1000944	3000623	353-0001	ENSEMBLE THERMISTANCE	1
36	4-1002745	5000027	536-0075	ENGRENAGE (PIGNON MOTEUR)	1
37	4-1000938	3000561	330-0005	ENSEMBLE MOTEUR	1
38	4-1070314	5000894	544-0022	BAGUE DE MAINTIEN COQUE	1
39	4-1002752	5000069	515-0003	VIS	2
40		3000912	903-0048	KIT COQUE TYPE NF POUR GX40V	1
42	4-1070143	PAL1803	541-0003	CROCHET	1
43	4-1070167	5000144	506-0012	FIXATION	1
44	4-1090118	PSK1327	557-0032	AIGUILLE	1
45	4-1077172	PSW2602	571-0025	VIS	3
46	4-1012329	PFF1130	316-0012	INTERRUPTEUR DE REVERSIBILITE	1
47	4-1070145	5000135	539-0005	DIFFUSEUR DE CHALEUR	1
48	4-1002759	5000143	903-0067	COUSSINET SILICONE THERMIQUE	1
49	4-1050631	3000162	332-0065	KIT CARTE ELECTRONIQUE DE COMMANDE <i>*Nota : Firmware non inclus (voir page 32)</i>	1
50	4-1002843	PFF1842A	582-0016	SUPPORT (PCB)	2
51	4-1090116	PFF1824	555-0001	ECROU	2

Rep	Code DOGA	Ancienne Ref.	Nouvelle Ref.	Description	GX450P-A
52	4-1002878	PSW2803	590-0021	RONDELLE	2
53	4-1070148	5000070	520-0005	BOUCHON	2
54	4-1077684	5000161	331-0012	KIT CARTE D'ALIMENTATION	1
56	4-1070151	5000659	548-0114	ETIQUETTE (FENETRE)	1
56	4-1070152	5000660	548-0115	ETIQUETTE (FENETRE)	1
57	4-1070316	5000898	582-0035	SUPPORT (RONDELLE COUPLE RESSORT)	1
58	4-1070332	-	582-0044	SUPPORT (COUPLE RESSORT)	1
59	4-1070321	5000904	527-0023	ANNEAU EN C (STOP)	1
60	4-1070322	5001027	547-0003	VIS	2
61	4-1070323	5001028	515-0024	VIS	2
64	4-1070341	5000914	582-0006	SUPPORT (BAGUE RESSORT)	1
65	4-1000920	-	557-0044	GOUPILLE (FIXE)	1

5. GXA 150, 200, 450 - G VUE ÉCLATÉE & LISTE DE PIÈCES

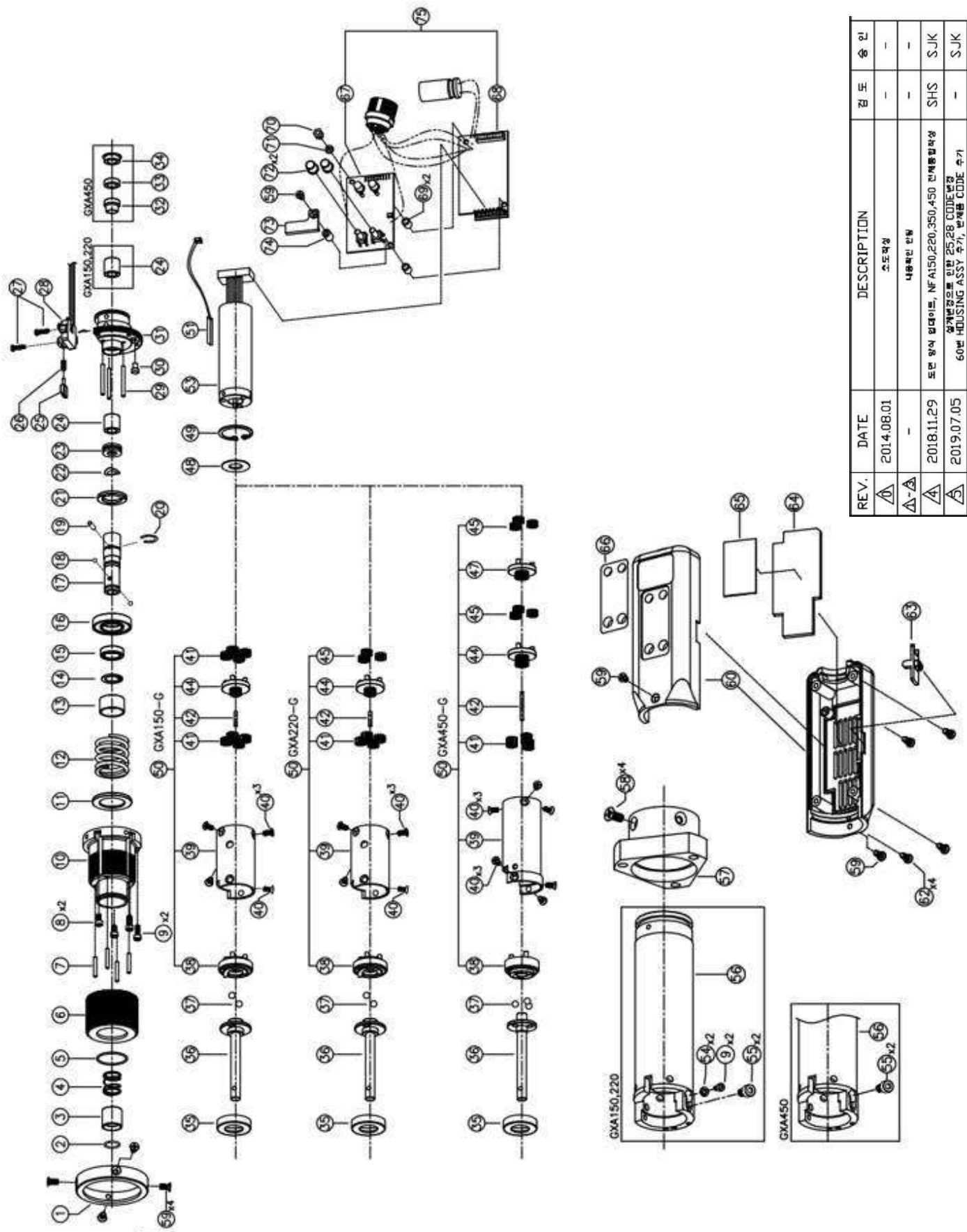

Rep	Code DOGA	Ancienne Ref.	Nouvelle Ref.	Description	GXA150-A	GXA220-A	GXA450-A
1	4-1070333	5001029	526-0036	COUVERCLE (POUSSIÈRE)	1	1	1
2	4-1075005	PAL1973	527-0017	ANNEAU EN C (DOUILLE EMBOUT)	1	1	1
3	4-1070304	5000892	524-0003	BAGUE	1	1	1
4	4-1070305	5000902	581-0025	RESSORT (BAGUE)	1	1	1
5	4-1070321	5000904	527-0023	ANNEAU EN C (STOP)	1	1	1
6	4-1070300	5000888	505-0002	BAGUE DE REGLAGE DE COUPLE	1	1	1
7	4-1070301	5000899	557-0003	GOUPILLE (AJUSTEMENT)	4	4	4
8	4-1075080	PSW2201	515-0008	VIS	2	2	2
9	4-1075008	PSW2204	515-0009	VIS	4	4	2
10	4-1077679	3000989	316-0024	ENCEINTE EMBRAYAGE	1	1	1
11	4-1070316	5000898	582-0035	SUPPORT (COUPLE RESSORT RONDELLE)	1	1	1
12	4-1070335	5000942	581-0065	RESSORT (COUPLE)	1		
12	4-1070336	5000943	581-0067	RESSORT (COUPLE)		1	
12	4-1070302	5000944	581-0069	RESSORT (COUPLE)			1
13	4-1070320	5000889	510-0001	PORTE-ROULEMENT	1	1	1
14	4-1070319	5001026	579-0013	ANNEAU DE SERRAGE	1	1	1
15	4-1070318	5001022	509-0022	ROULEMENT (BILLE)	1	1	1
16	#N/A	5000897	582-0037	SUPPORT (COUPLE RESSORT)	1	1	1
17	4-1070306	5000890	514-0010	DOUILLE EMBOUT (A)	1	1	1
18	4-1075014	PAL1928	507-0003	BILLE	2	2	2
19	4-1077135	PAL1231	557-0017	PION (PORTE SATELLITE)	1	1	1
20	4-1075018	PSK1954	527-0006	ANNEAU EN C	1	1	1
21	4-1070332	-	582-0044	SUPPORT (COUPLE RESSORT)	1	1	1
22	4-1070310	5000887	590-0032	RONDELLE (CONIQUE)	1	1	
22	#N/A	PAL1946	590-0030	RONDELLE (CONIQUE)			1
23	4-1090119	PSK1921	509-0035	ROULEMENT (SECONDAIRE)	1	1	1

Rep	Code DOGA	Ancienne Ref.	Nouvelle Ref.	Description	GXA150-A	GXA220-A	GXA450-A
24	4-1002754	5000077	509-0028	ROULEMENT (SANS HUILE)	2	2	1
25	4-1090199	-	349-0003	ENSEMBLE COULISSANT	1	1	1
26	4-1002749	5000064	581-0043	RESSORT (LIMITE)	1	1	1
27	4-1075114	PSW2211	571-0012	VIS	2	2	2
28	4-1090197	-	346-0022	ENSEMBLE CAPTEUR (LEVIER)	1	1	1
29	4-1070338	5000900	557-0028	AIGUILLE	3	3	
	4-1070311	5000901	557-0029	AIGUILLE			3
30	4-1070209	5000291	557-0009	GOUPILLE (FIXE)	1	1	1
31	4-1002762	3000079	304-0008	BRIDE SUPPORT (LEVIER)	1	1	
31	4-1070222	3000531	304-0013	BRIDE SUPPORT (LEVIER)			1
32	4-1090077	5000297	582-0002	SUPPORT (ROULEMENT)			1
33	4-1002783	5000376	509-0001	ROULEMENT (BILLE)			1
34	4-1002784	5000377	509-0002	ROULEMENT (BILLE)			1
35	4-1090115	PFF1319	569-0011	ANNEAU COULISSANT	1	1	
35	4-1075103	PFE1319	569-0010	ANNEAU COULISSANT			1
36	4-1002750	5000066	573-0001	ARBRE (LEVIER)	1	1	
36	4-1070188	5000084	573-0003	ARBRE (LEVIER)			1
37	4-1075106	PAL1932	507-0005	BILLE	2	2	
37	4-1070206	5000300	507-0004	BILLE			3
38	4-1002708	3000268	311-0017	ENSEMBLE EMBRAYAGE	1		
38	4-1077680	3000269	311-0019	ENSEMBLE EMBRAYAGE		1	
38	4-1012505	-	311-0030	ENSEMBLE EMBRAYAGE			1
39	4-1090108	PFE1201A	536-0048	CARTER ENGRENAGE	1		
39	4-1002796	5000491	536-0046	CARTER ENGRENAGE		1	
39	4-1070223	5000450	536-0057	CARTER ENGRENAGE			1
40	4-1002835	5000665	571-0001	VIS (FL TORX)	4	4	6
41	4-1002751	5000067	536-0028	PIGNON (2EME ETAGE)	8		

Rep	Code DOGA	Ancienne Ref.	Nouvelle Ref.	Description	GXA150-A	GXA220-A	GXA450-A
41	4-1075118	PFE1212	536-0024	PIGNON (2EME ETAGE B)		4	
41	4-1055333	5000009	536-0039	PIGNON (3EME ETAGE)			3
42	4-1090113	PFE1915	557-0007	GOUPILLE (CENTRAGE)	1	1	
42	4-1090118	PSK1327	557-0032	AIGUILLE			1
44	4-1002850	PFE1102	325-0009	PORTE SATELLITE	1		
44	4-1075123	PFE1103	325-0012	PORTE SATELLITE		1	
44	4-1055334	3000170	325-0016	PORTE SATELLITE			1
45	4-1002758	5000134	536-0018	SATELLITE (1ER ETAGE)		3	
45	4-1055335	5000008	536-0009	ENGRENAGE (SATELLITE)			6
47	4-1002707	3000175	325-0007	PORTE SATELLITE			1
48	4-1090114	PFE1947	590-0005	RONDELLE	1	1	1
49	4-1075125	PFE1903	578-0004	ANNEAU DE SERRAGE	1	1	1
50		-	330-0081	BOITIER D'ENGRENAGE	1		
50		-	330-0082	BOITIER D'ENGRENAGE		1	
50		-	330-0088	BOITIER D'ENGRENAGE			1
51	4-1000944	3000623	353-0001	ENSEMBLE THERMISTANCE	1	1	1
52	4-1090111	PFE1235	536-0094	ENGRENAGE (PIGNON)	1		
52	4-1075127	PFE1236	536-0088	ENGRENAGE (PIGNON B)		1	
52	4-1002745	5000027	536-0075	ENGRENAGE (PIGNON MOTEUR)			1
53	4-1000938	3000561	330-0005	ENSEMBLE MOTEUR	1	1	1
54	4-1070210	PSW2805	590-0023	RONDELLE	2	2	
55	4-1002752	5000069	515-0003	VIS	2	2	
55	4-1002793	5000476	515-0005	VIS			2
56	4-1070212	5000289	574-0003	COQUILLE	1	1	1
57	4-1070331	5001030	532-0004	BRIDE	1	1	1
58	4-1077400	5000545	515-0001	VIS	4	4	4
59	4-1075115	PSW2207	571-0010	VIS	7	7	7

Rep	Code DOGA	Ancienne Ref.	Nouvelle Ref.	Description	GXA150-A	GXA220-A	GXA450-A
60	4-1001032	-	327-0024	KIT COQUE	1	1	1
62	4-1077172	PSW2602	571-0025	VIS	4	4	4
63	4-1012329	PFF1130	316-0012	INTERRUPTEUR DE REVERSIBILITE	1	1	1
64	4-1070145	5000135	539-0005	DIFFUSEUR DE CHALEUR	1	1	1
65	4-1002759	5000143	903-0067	COUSSINET SILICONE THERMIQUE	1	1	1
66	4-1070220	5000662	548-0117	ETIQUETTE (FENETRE)	1	1	1
67	4-1050633	3000558	332-0077	KIT CARTE ELECTRONIQUE DE COMMANDE <i>*Nota : Firmware non inclus (voir page 32)</i>	1	1	1
68	4-1070218	3000555	331-0007	KIT CARTE D'ALIMENTATION	1	1	1
69	4-1002843	PFF1842A	582-0016	SUPPORT (PCB)	2	2	2
70	4-1090116	PFF1824	555-0001	ECROU	1	1	1
71	4-1002878	PSW2803	590-0021	RONDELLE	1	1	1
72	4-1070148	5000070	520-0005	BOUCHON	2	2	2
73	4-1012345	PFF1719	526-0020	COUVERCLE (VERROUILLAGE CONNECTEUR)	1	1	1
74	4-1078885	PFF1824A	555-0002	ECROU	1	1	1
75	4-1050634	3000529	903-0099	ENSEMBLE CARTE COMMANDE <i>*Nota : Firmware non inclus (voir page 32)</i>	1	1	1

6. GXS 150, 200 - G (LEVIER) VUE ÉCLATÉE & LISTE DE PIÈCES

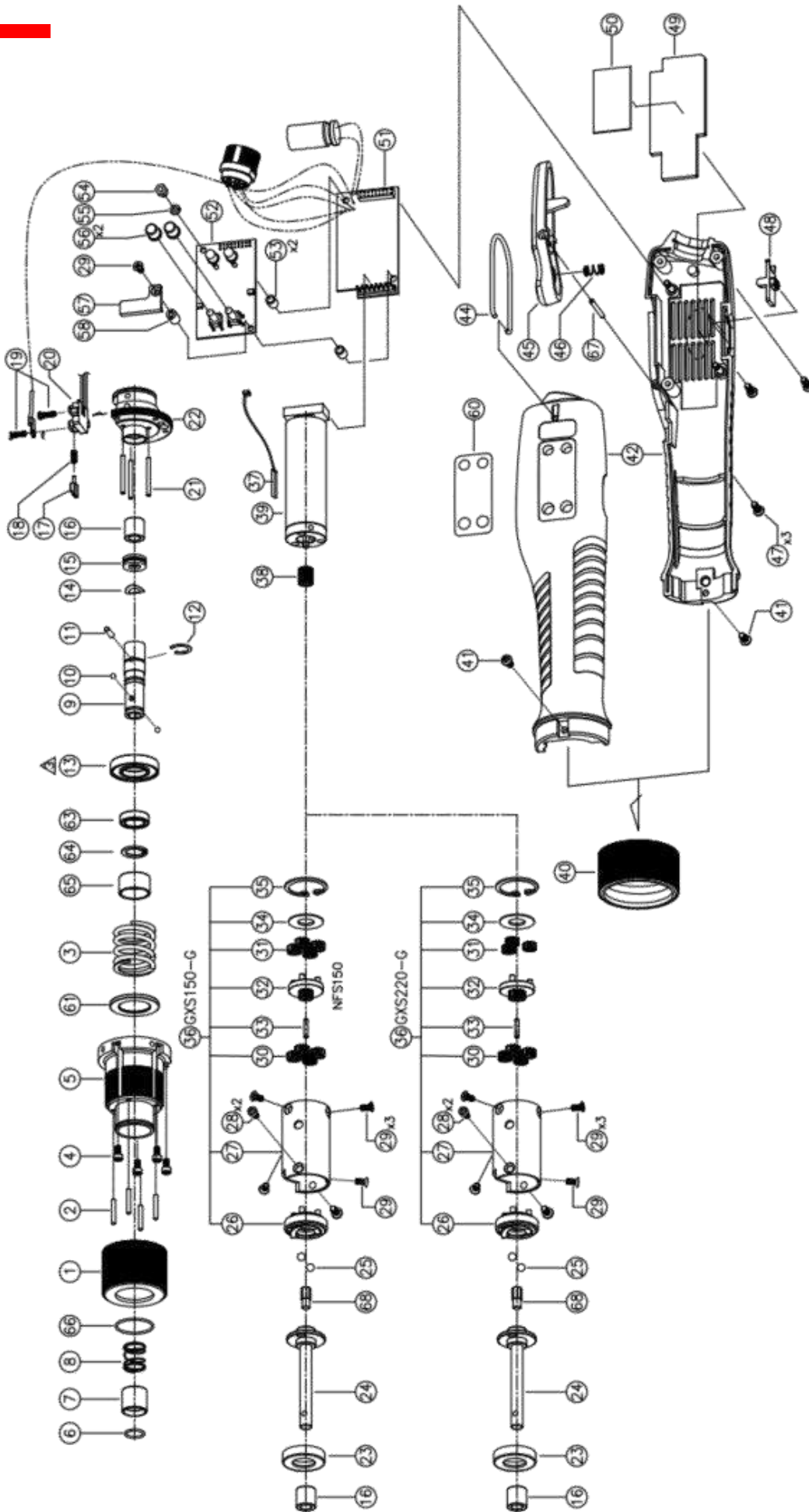

REV.	DATE	DESCRIPTION	검도	승인
1	2014.08.01	초도 작성	-	-
2	-	수정내용 확인 안됨	-	-
3	2018.08.08	도면 양자 업데이트, HOUSING 수정 62와제, 13번 수정	SHS	SJK
4	2019.07.05	설계변경으로 인한 17, 20 CODE 변경 42번 HOUSING ASSY 추가, 반제품 CODE 추가	-	SJK

Rep	Code DOGA	Ancienne Ref.	Nouvelle Ref.	Description	GXS150-A	GXS220-A
1	4-1070300	5000888	505-0002	BAGUE DE REGLAGE DE COUPLE	1	1
2	4-1070301	5000899	557-0003	GOUPILLE (AJUSTEMENT)	4	4
3	4-1070335	5000942	581-0065	RESSORT (COUPLE)	1	
3	4-1070336	5000943	581-0067	RESSORT (COUPLE)		1
4	4-1075080	PSW2201	515-0008	VIS	4	4
5	4-1077679	3000989	316-0024	ENCEINTE EMBRAYAGE	1	1
6	4-1075005	PAL1973	527-0017	ANNEAU EN C (DOUILLE EMBOUT)	1	1
7	4-1070304	5000892	524-0003	BAGUE	1	1
8	4-1070305	5000902	581-0025	RESSORT (BAGUE)	1	1
9	4-1070306	5000890	514-0010	DOUILLE EMBOUT (A)	1	1
10	4-1075014	PAL1928	507-0003	BILLE	2	2
11	4-1077135	PAL1231	557-0017	PION (PORTE SATELLITE)	1	1
12	4-1075018	PSK1954	527-0006	ANNEAU EN C	1	1
13	4-1070332		582-0044	SUPPORT (COUPLE RESSORT)	1	1
14	4-1070310	5000887	590-0032	RONDELLE (CONIQUE)	1	1
15	4-1090119	PSK1921	509-0035	ROULEMENT (SECONDAIRE)	1	1
16	4-1002754	5000077	509-0028	ROULEMENT (SANS HUILE)	2	2
17	4-1090199	-	349-0003	ENSEMBLE COULISSANT	1	1
18	4-1002749	5000064	581-0043	RESSORT (LIMITE)	1	1
19	4-1075114	PSW2211	571-0012	VIS	2	2
20	4-1090195	-	346-0020	ENSEMBLE CAPTEUR (LEVIER)	1	1
21	4-1070338	5000900	557-0028	AIGUILLE	3	3
22	4-1002762	3000079	304-0008	BRIDE SUPPORT (LEVIER)	1	1
23	4-1090115	PFF1319	569-0011	ANNEAU COULISSANT	1	1
24	#N/A	3000618	347-0006	ARBRE (LEVIER)	1	1
25	4-1075106	PAL1932	507-0005	BILLE	2	2

Rep	Code DOGA	Ancienne Ref.	Nouvelle Ref.	Description	GXS150-A	GXS220-A
26		3000617	311-0001	ENSEMBLE EMBRAYAGE	1	
26		3001029	311-0027	ENSEMBLE EMBRAYAGE		1
27	4-1002796	5000491	536-0046	CARTER ENGRENAGE		1
27	4-1090108	PFE1201A	536-0048	CARTER ENGRENAGE	1	
28	4-1075008	PSW2204	515-0009	VIS	2	2
29	4-1002835	5000665	571-0001	VIS (FL TORX)	5	5
30	4-1002751	5000067	536-0028	PIGNON (2EME ETAGE)	4	
30	4-1075118	PFE1212	536-0024	PIGNON (2EME ETAGE B)		4
31	4-1002751	5000067	536-0028	PIGNON (2EME ETAGE)	4	
31	4-1002758	5000134	536-0018	SATELLITE (1ER ETAGE)		3
32	4-1002850	PFE1102	325-0009	PORTE SATELLITE	1	
32	4-1075123	PFE1103	325-0012	PORTE SATELLITE		1
33	4-1090113	PFE1915	557-0007	GOUPILLE (CENTRAGE)	1	1
34	4-1090114	PFE1947	590-0005	RONDELLE	1	1
35	4-1075125	PFE1903	578-0004	ANNEAU DE SERRAGE	1	1
36		-	330-0089	BOITIER D'ENGRENAGE	1	
36		-	330-0090	BOITIER D'ENGRENAGE		1
37	4-1000944	3000623	353-0001	ENSEMBLE THERMISTANCE	1	1
38	4-1090111	PFE1235	536-0094	ENGRENAGE (PIGNON)	1	
38	4-1075127	PFE1236	536-0088	ENGRENAGE (PIGNON B)		1
39	4-1000938	3000561	330-0005	ENSEMBLE MOTEUR	1	1
40	4-1070339	5000893	544-0020	BAGUE DE MAINTIEN COQUE	1	1
41	4-1002753	5000072	571-0016	VIS	2	2
42	#N/A	3000912	903-0048	KIT COQUE TYPE NF POUR GX40V	1	1
44	4-1070143	PAL1803	541-0003	CROCHET	1	1
45	4-1002705	3000160	329-0014	ENSEMBLE LEVIER	1	1

Rep	Code DOGA	Ancienne Ref.	Nouvelle Ref.	Description	GXS150-A	GXS220-A
46	4-1090112	PFE1841	581-0037	RESSORT (LEVIER)	1	1
47	4-1077172	PSW2602	571-0025	VIS	3	3
48	4-1012329	PFF1130	316-0012	INTERRUPTEUR DE REVERSIBILITE	1	1
49	4-1070145	5000135	539-0005	DIFFUSEUR DE CHALEUR	1	1
50	4-1002759	5000143	903-0067	COUSSINET SILICONE THERMIQUE	1	1
51	4-1077684	3000161	331-0012	KIT CARTE D'ALIMENTATION	1	1
52	4-1050632	3000270	332-0062	KIT CARTE ELECTRONIQUE DE COMMANDE <i>*Nota : Firmware non inclus (voir page 32)</i>	1	1
53	4-1002843	PFF1842A	582-0016	SUPPORT (PCB)	2	2
54	4-1090116	PFF1824	555-0001	ECROU	1	1
55	4-1002878	PSW2803	590-0021	RONDELLE	1	1
56	4-1070148	5000070	520-0005	BOUCHON	2	2
57	4-1012345	PFF1719	526-0020	COUVERCLE (VERROUILLAGE CONNECTEUR)	1	1
58	4-1078885	PFF1824A	555-0002	ECROU	1	1
60	4-1070151	5000659	548-0114	ETIQUETTE (FENETRE)	1	1
60	4-1070152	5000660	548-0115	ETIQUETTE (FENETRE)	1	1
60	4-1070153	5000661	548-0116	ETIQUETTE (FENETRE)	1	1
61	4-1070316	5000898	582-0035	SUPPORT (COUPLE RESSORT RONDELLE)	1	1
63	4-1070318	5001022	509-0022	ROULEMENT (BILLE)	1	1
64	4-1070319	5001026	579-0013	ANNEAU DE SERRAGE	1	1
65	4-1070320	5000889	510-0001	PORTE-ROULEMENT	1	1
66	4-1070321	5000904	527-0023	ANNEAU EN C (STOP)	1	1
67	4-1090118	PSK1327	557-0032	AIGUILLE	1	1
68	4-1000943	5000568	573-0019	ARBRE (EMBRAYAGE)	1	1

7. GXA 450P - G VUE ÉCLATÉE & LISTE DE PIÈCES

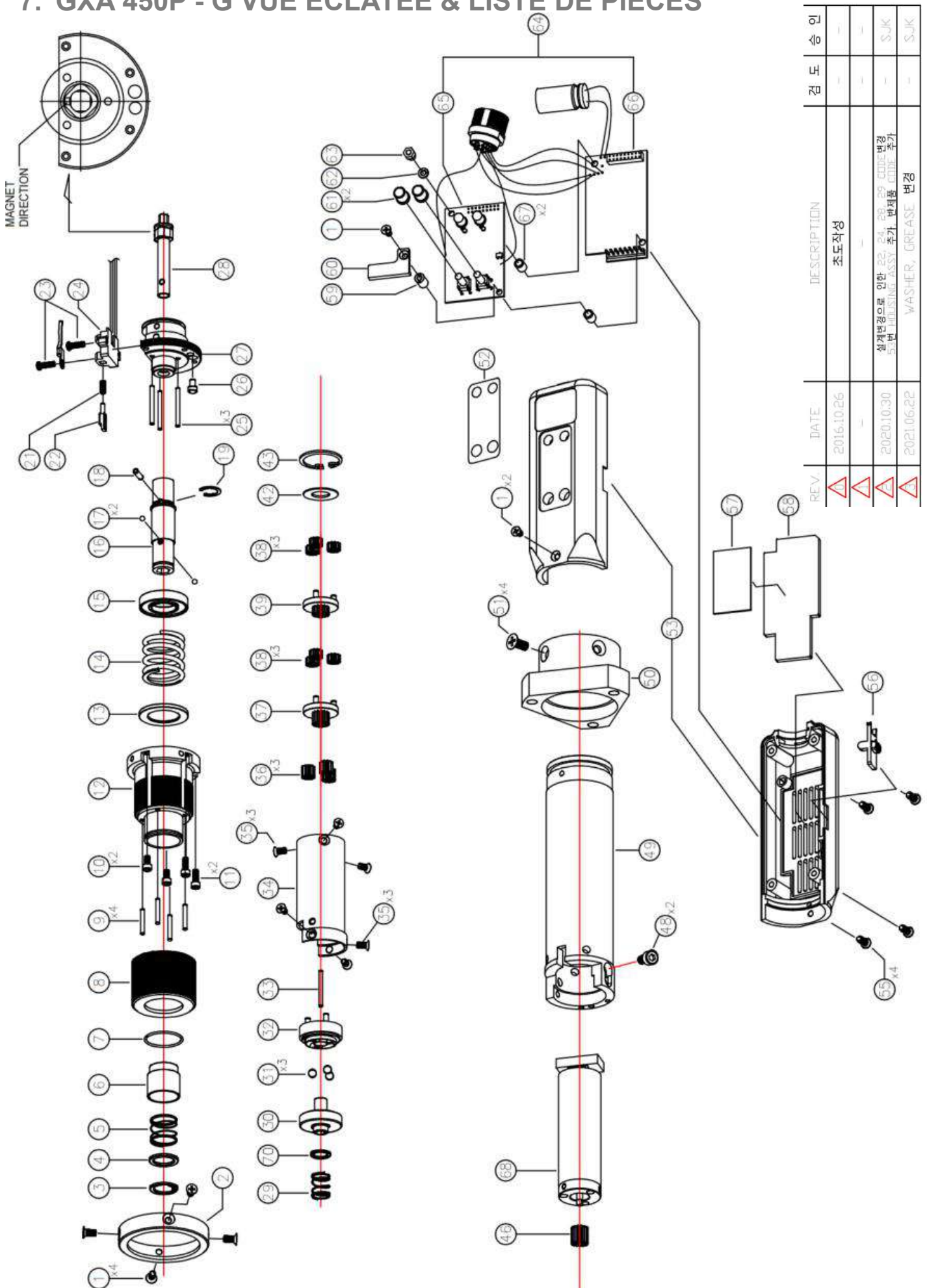

REV	DATE	DESCRIPTION	검도 승인
△A	2016.10.26	초도작성	-
△A	-	-	-
△A	2020.10.30	실제반경으로 인한 22, 24, 25, 29 CODE 변경 5번 HOUSING ASSY 추가. 부품품 CODE 추가	SJK
△A	2021.06.22	WASHER, GREASE 변경	SJK

Rep	Code DOGA	Ancienne Ref.	Nouvelle Ref.	Description	GXA450P
1	4-1075115	PSW2207	571-0010	VIS	7
2	4-1070333	5001029	526-0036	COUVERCLE (POUSSIÈRE)	1
3	4-1070325	5000945	579-0002	ANNEAU DE SERRAGE	1
4	4-1070341	5000914	582-0006	SUPPORT (BAGUE RESSORT)	1
5	4-1070328	5000903	581-0026	RESSORT (BAGUE)	1
6	4-1070326	5000912	524-0007	BAGUE (A)	1
7	4-1070321	5000904	527-0023	ANNEAU EN C (STOP)	1
8	4-1070300	5000888	505-0002	BAGUE DE REGLAGE DE COUPLE	1
9	4-1070301	5000899	557-0003	GOUPILLE (AJUSTEMENT)	4
10	4-1075080	PSW2201	515-0008	VIS	2
11	4-1075008	PSW2204	515-0009	VIS	2
12	4-1070324	3000949	316-0023	ENCEINTE EMBRAYAGE	1
13	4-1070316	5000898	582-0035	SUPPORT (COUPLE RESSORT RONDELLE)	1
14	4-1070302	5000944	581-0069	RESSORT (COUPLE)	1
15	4-1070332	582-0037	582-0044	SUPPORT (COUPLE RESSORT)	1
16	4-1070329	5000909	514-0009	DOUILLE EMBOUT (A)	1
17	4-1090109	PAL1929	507-0002	BILLE	2
18	4-1077135	PAL1231	557-0017	PION (PORTE SATELLITE)	1
19	4-1075018	PSK1954	527-0006	ANNEAU EN C	1
21	4-1002749	5000064	581-0043	RESSORT (LIMITE)	1
22	4-1090199	-	349-0003	ENSEMBLE COULISSANT	1

Rep	Code DOGA	Ancienne Ref.	Nouvelle Ref.	Description	GXA450P
23	4-1075114	PSW2211	571-0012	VIS	2
24	4-1090198	-	346-0023	ENSEMBLE CAPTEUR (POUSSEE)	1
25	4-1070311	5000901	557-0029	AIGUILLE	3
26	4-1070209	5000291	557-0009	GOUPILLE (FIXE)	1
27		-	304-0056	BRIDE SUPPORT (POUSSEE)	1
28		-	347-0031	ENSEMBLE ARBRE (POUSSEE)	1
29		-	581-0102	RESSORT (POUSSEE)	1
30	4-1070205	3000280	347-0016	ENSEMBLE ARBRE (B)	1
31	4-1070206	5000300	507-0004	BILLE	3
32	4-1012505	-	311-0030	ENSEMBLE EMBRAYAGE	1
33	4-1090118	PSK1327	557-0032	AIGUILLE	1
34	4-1070223	5000450	536-0057	CARTER ENGRENAGE	1
35	4-1002835	5000665	571-0001	VIS (FL TORX)	6
36	4-1055333	5000009	536-0039	PIGNON (3EME ETAGE)	3
37	4-1055334	3000170	325-0016	PORTE SATELLITE	1
38	4-1055335	5000008	536-0009	ENGRENAGE (SATELLITE)	6
39	4-1002707	3000175	325-0007	PORTE SATELLITE	1
42	4-1000934	-	590-0048	RONDELLE	1
43	4-1075125	PFE1903	578-0004	ANNEAU DE SERRAGE	1
44	4-1070347	PSW2216	515-0012	VIS	3
45	4-1077551	PFF1839A	532-0023	BRIDE	1
46	4-1002745	5000027	536-0075	ENGRENAGE (PIGNON MOTEUR)	1

Rep	Code DOGA	Ancienne Ref.	Nouvelle Ref.	Description	GXA450P
47	4-1070139	5000418	551-0010	MOTEUR BRUSHLESS	1
48	4-1002793	5000476	515-0005	VIS	2
49	4-1070212	5000289	574-0003	COQUILLE	1
50	4-1070331	5001030	532-0004	BRIDE	1
51	4-1077400	5000545	515-0001	VIS	4
52	4-1070220	5000662	548-0117	ETIQUETTE (FENETRE)	1
53	4-1001032	-	327-0024	KIT COQUE	1
55	4-1077172	PSW2602	571-0025	VIS	4
56	4-1012329	PFF1130	316-0012	INTERRUPTEUR DE REVERSIBILITE	1
57	4-1002759	5000143	903-0067	COUSSINET SILICONE THERMIQUE	1
58	4-1070145	5000135	539-0005	DIFFUSEUR DE CHALEUR	1
59	4-1078885	PFF1824A	555-0002	ECROU	1
60	4-1012345	PFF1719	526-0020	COUVERCLE (VERROUILLAGE CONNECTEUR)	1
61	4-1070148	5000070	520-0005	BOUCHON	2
62	4-1002878	PSW2803	590-0021	RONDELLE	1
63	4-1090116	PFF1824	555-0001	ECROU	1
64	4-1050634	3000529	903-0099	ENSEMBLE CARTE COMMANDE	1
65	4-1050633	3000558	332-0077	KIT CARTE ELECTRONIQUE DE COMMANDE	1
66	4-1070218	3000555	331-0007	KIT CARTE D'ALIMENTATION	1

Rep	Code DOGA	Ancienne Ref.	Nouvelle Ref.	Description	GXA450P
67	4-1002843	PFF1842A	582-0016	SUPPORT (PCB)	2
68	4-1000938	3000561	330-0005	ENSEMBLE MOTEUR	1
69	4-1000944	3000623	353-0001	ENSEMBLE THERMISTANCE	1
70		-	580-0029	ENTRETOISE	1

8. FIRMWARE TABLE

Logiciel à commander séparément et à installer par le Service SAV de DOGA.

TYPE	Modèle	Code DOGA	Désignation	Signaux	Sécurité
STANDARD	GX/S 150 (L & P)	4-1035201	FIRMWARE STANDARD GX150ST	Rotation (RUN) en vissage uniquement. Couple atteint (TORQUE UP) en vissage uniquement.	La rotation est libre dans les deux sens. L'opérateur peut modifier la vitesse et l'accélération.
	GX/S 220 (L & P)	4-1035202	FIRMWARE STANDARD GX220ST		
	GX450 (L & P)	4-1035251	FIRMWARE STANDARD GX450ST		
	GXA150 (E & P)	4-1035203	FIRMWARE STANDARD GXA150ST		
	GXA220 (E & P)	4-1035204	FIRMWARE STANDARD GXA220ST		
	GXA450 (E & P)	4-1035205	FIRMWARE STANDARD GXA450ST		
	GXT150	4-1035217	FIRMWARE STANDARD GXT150ST	Rotation (RUN) en vissage et dévissage. Couple atteint (TORQUE UP) en vissage uniquement.	La rotation est libre dans les deux sens. L'opérateur peut modifier la vitesse et l'accélération. L'opérateur peut modifier le reverse.
	GXT220	4-1035218	FIRMWARE STANDARD GXT220ST		
	GXT450	4-1035219	FIRMWARE STANDARD GXT450ST		
LOCK KEY	GX/S 150 (L & P)	4-1035221	FIRMWARE LOCK KEY GX150LK	Rotation (RUN) en vissage uniquement. Couple atteint (TORQUE UP) en vissage uniquement.	La rotation est libre dans les deux sens. Verrouillage des boutons, impossible de modifier la vitesse et le soft start sans la clé de déverrouillage.
	GX/S 220 (L & P)	4-1035222	FIRMWARE LOCK KEY GX220LK		
	GX450 (L & P)	4-1035223	FIRMWARE LOCK KEY GX450LK		
	GXT150	4-1035231	FIRMWARE SPECIAL LOCK KEY GXT150LK	Rotation (RUN) en vissage et dévissage. Couple atteint (TORQUE UP) en vissage uniquement.	La rotation est libre dans les deux sens. Verrouillage des boutons, impossible de modifier la vitesse, le reverse et soft start sans la clé de déverrouillage.
	GXT220	4-1035232	FIRMWARE SPECIAL LOCK KEY GXT220LK		
	GXT450	4-1035233	FIRMWARE SPECIAL LOCK KEY GXT450LK		
REVERSE CCW	GXA450	4-1035235	FIRMWARE REVERSE GXA450CCW	Signaux (sens anti-horaire) : Rotation (RUN) en vissage uniquement. Couple atteint (TORQUE UP) en vissage uniquement.	La rotation est libre dans les deux sens. L'opérateur peut modifier la vitesse et l'accélération.
2 WAYS SIGNALS	GX150 GXS150	4-1035236	FIRMWARE 2 SENS GX150RTVD	Rotation (RUN) en vissage et dévissage. Couple atteint (TORQUE UP) en vissage et dévissage.	La rotation est libre dans les deux sens. L'opérateur peut modifier la vitesse et l'accélération.
	GX220 GXS220	4-1035237	FIRMWARE 2 SENS GX220RTVD		
	GX450	4-1035238	FIRMWARE 2 SENS GX450RTVD		
DOUBLE LOCK	GX150 GXS150	4-1035239	FIRMWARE DOUBLE LOCK GX150DL	Double verrouillage des paramètres avec une clé + un DPC Touch. Rotation (RUN) en vissage uniquement. Couple atteint (TORQUE UP) en vissage uniquement.	La rotation est libre dans les deux sens. Double verrouillage des boutons, impossible de modifier la vitesse et soft start sans la clé de déverrouillage + DPC Touch.
	GX220 GXS220	4-1035240	FIRMWARE DOUBLE LOCK GX220DL		
	GX450	4-1035241	FIRMWARE DOUBLE LOCK GX450DL		

LOCK REMOTE	GX150 GXS150	4-1035242	FIRMWARE LOCK REMOTE GX150LR	Rotation (RUN) en vissage uniquement. Couple atteint (TORQUE UP) en vissage uniquement.	La rotation est libre dans les deux sens. Verrouillage des boutons, impossible de modifier la vitesse et soft start sans la commande externe.
	GX220 GXS220	4-1035243	FIRMWARE LOCK REMOTE GX220LR		
	GX450	4-1035244	FIRMWARE LOCK REMOTE GX450LR		

