

6

The most versatile vises!

MULTIFLEX

Morsé e Cubi / Vises & Vise Towers

DOGA® | USINAGE

✉ usinage-fraisage@doga.fr

☎ +33 1 30 66 41 41

📍 8, avenue Gutenberg - CS 50510
78317 Maurepas Cedex - FRANCE

© DOGA | DOC.10103.04/24

Nous travaillons constamment à l'amélioration de nos produits. De ce fait, les dimensions et indications portées dans cette brochure peuvent parfois ne pas correspondre aux dernières exécutions. De convention expresse, nos ventes sont faites sous bénéfice de réserve de propriété (les dispositions de la loi du 12/05/1980 trouvent donc toute leur application).

www.doga-usinage.fr

VALIGETTA DI CAMPIONATURA STD (Art.600)

SAMPLE KIT CASE STD (Art.600)



Art. 984

Valigetta di campionatura morsa Art.600 T.1x400
 Sample kit case Art.600 T.1x400 vise

Cod. 0.98.40000

All'Interno - Inside:

	Art.604		Art.610B		Art.297
	Art.605		Art.610C		Art.298
	Art.609		Art.610D		Art.370
	Art.613		Art.610E		Art.375
	Art.615		Art.610F		Art.376
	Art.605L		Art.610T	-	-



SIMBOLOGIA DATI TECNICI

TECHNICAL DATA ICONS

GANASCE JAWS		Fissa Fixed		Mobile e fissa Fixed and movable		Mobile e fissa a gradino Fixed and movable with step		Mobile doppia Double movable
	PIASTRE GANASCE JAW PLATES		Piana Straight		GRIP integrale Integral GRIP			
POSSIBILITÀ POSSIBILITY			Predisposizione Zero Point Zero Point Ready		Cubi-morsa Vise tower		Divisore automatico Dividing head	
	PAGINE PAGES		Accessori & Ricambi Accessories & Spare Parts		Istruzioni corretto utilizzo Instruction for a proper use		Diagrammi forze di serraggio Clamping force diagrams	

Morse e cubi morsa / Vises & vise-towers

MULTIFLEX SERIES



Precisione / Accuracy
 $\pm 0,02\text{mm}$



Durezza / Hardened
HRC 58 \pm 2

Per serraggi multipli fino a 19 particolari di varie dimensioni

For flexible clamping of multiple workpieces of various sizes

USURA INESISTENTE / NO WEAR

Grazie all'accurata scelta dei materiali impiegati ed allo studio dimensionale computerizzato dei componenti. Costruzione completamente in speciali leghe di acciaio ad alta resistenza, normalizzato, cementato e temprato con durezza 60 \pm 2 HRC. Tutto ciò al fine di conferire massima rigidità, elevate prestazioni e usura inesistente. A riprova di tutto ciò assicuriamo 5 ANNI DI GARANZIA su tutto il programma morse e organi meccanici in genere.

Thanks to the manufacturing with only the most suitable materials and to the structure of the vise components (developed using computer customised softwares and the experience gained during many years spent working on the specific field).

High alloyed quality resistance steel, case hardened HRC 60 \pm 2, is used in manufacturing all the Gerardi vises and accessories in order to give maximum rigidity, high performances and no wear. As evidence we give 5 YEARS WARRANTY on all the vises and mechanical components.

TEMPI DI ATTREZZAZGIO RIDOTTI REDUCED SET-UP TIMES

Posizionamenti ed ancoraggi delle ganasce sul corpo base di rapida esecuzione ed in prossimità del particolare da lavorare.

Quick and versatile jaws positioning very close to the workpiece.

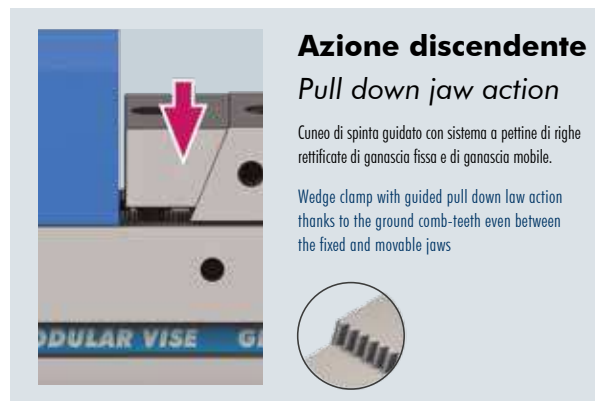

Azione discendente

Pull down jaw action

Cuneo di spinta guidato con sistema a pettine di righe rettificate di ganascia fissa e di ganascia mobile.

Wedge clamp with guided pull down low action thanks to the ground comb-teeth even between the fixed and movable jaws



SERRAGGI ILLIMITATI / UNLIMITED CLAMPING

(Ganasce a gradino, zigrinate, lisce, per tondi, dolci, doppie, ecc.) La posizione, il numero o il tipo di ganascia può variare a seconda delle necessità di serraggio (possibilità di bloccare da 1 a 19 pezzi sulla stessa morso) Pag.6.21

(Step jaws, serrated, flat, prismatic, soft, double, etc.) The jaws positioning, number or type could vary according to the workholding needs (from 1 to 19 pcs. clamping possibility on the same vise base) Page. 6.21



Montaggio in parallelo

Parallel mounting

10 morse - Serraggio di 1 particolare
10 vises - 1 workpiece clamped



Montaggio in parallelo

Parallel mounting

10 morse - Serraggio di 4 particolari
10 vises - 4 workpiece clamped



Montaggio in Linea

In line mounting

6 morse - Serraggio di 8 particolari
6 vises - 8 workpiece clamped



Montaggio in Linea

In line mounting

6 morse - Serraggio di 24 particolari
6 vises - 24 workpiece clamped

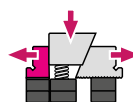

Ganascia fissa e mobile
con gradino per il sollevamento del particolare
Fixed & Movable jaw
with step to rise up the workpiece

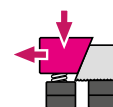

Ganascia fissa e mobile
per particolari in appoggio sulla base.
Fixed & Movable jaw
with step to rise up the workpiece

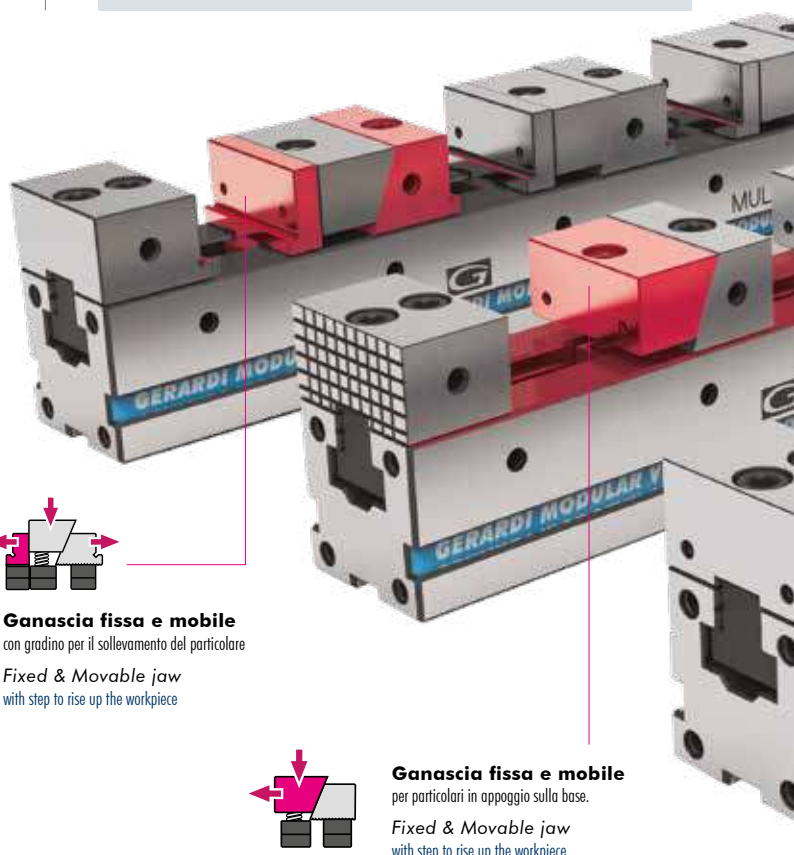

Le morse della serie MULTIFLEX rappresentano un innovativo sistema modulare di serraggio in grado di sfruttare al massimo la capacità della tavola della macchina e di aumentarne, di conseguenza, la produttività. Il sistema è stato ideato per poter serrare contemporaneamente un notevole numero di pezzi sulla tavola della macchina utensile, riducendo così notevolmente i tempi morti.

The MULTIFLEX series vises are a total new concept of modular clamping system able to maximize the machine table capacity and thus to increase its productivity. This system is designated for clamping several workpieces at the same time on the machine tool table, thus reducing tool changeover times.

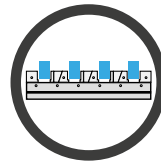

SCAN IT TO WATCH THE



VIDEO PRESENTATION



Le morse più versatili!
The most versatile vises!

Massima precisione garantita
Highest accuracy guaranteed

Di posizionamento ed allineamento delle ganasce e delle morse grazie alla rettificatura dal pieno della dentatura di ancoraggio della base.

In positioning and alignment ($\pm 0,02$ mm) thanks to the ground rack teeth on both the base and the fixed jaws.

Versatilità
Versatility

Possibilità di posizionamento, aggiunta o rimozione ganasce su qualsiasi posizione della dentatura.

Possibility of jaws positioning, addition or remove on whatever position on the vise base teeth

2 mm
 Passo delle righe
 Rows pitch

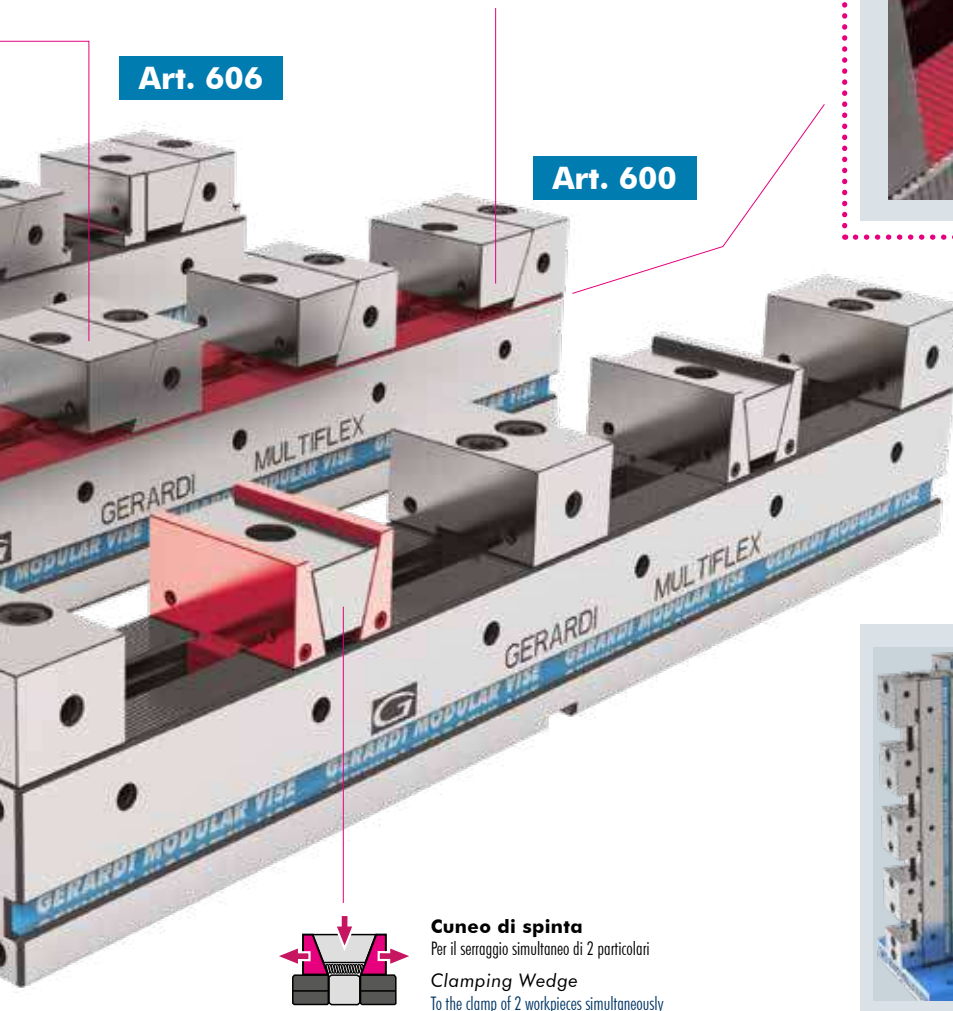
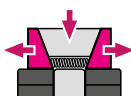
Art. 606
Art. 600
Art. 611

Cuneo di spinta
 Per il serraggio simultaneo di 2 particolari
Clamping Wedge
 To the clamp of 2 workpieces simultaneously



Montaggio Verticale
Vertical Set-Up

Tramite distanziali, strutture portapezzi o cubi-morsa verticali. Le morse modulari MULTIFLEX possono essere assemblate verticalmente, legate fra loro o montate su specifiche strutture portapezzi.

Through spacers, tombstones or vise-towers. MULTIFLEX vises can be vertically assembled linked each other or clamped to specific workholding structures.

Staffe d'ancoraggio / Vise holding clamps

NEW
2024

MULTIFLEX

Coppia staffe di fissaggio Art.296, complete di vite e dado a "T"
Pair of vise holding clamps Art.296 complete of screw and "T" nuts

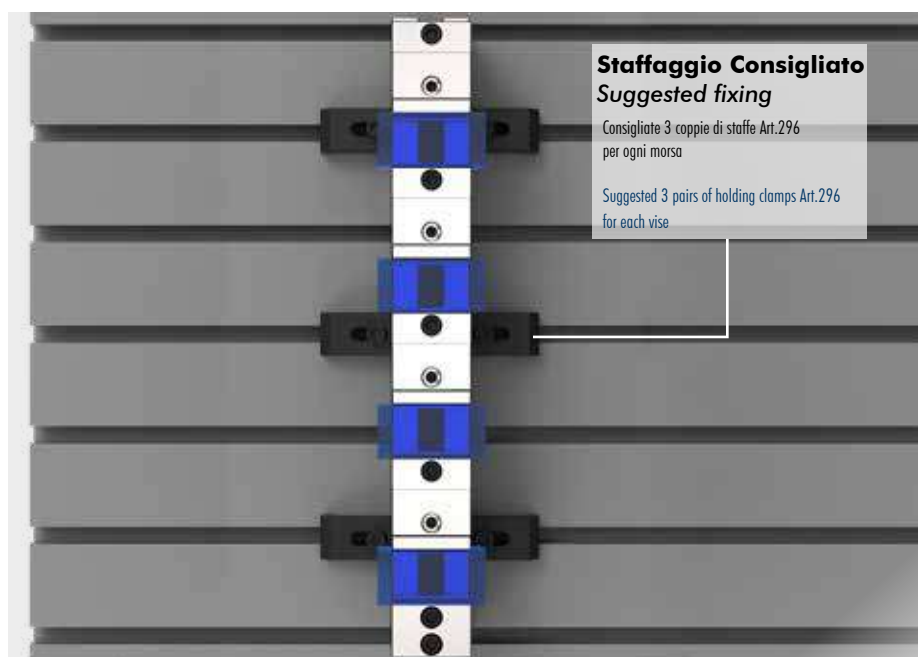
Esempio d'ordine per morsa tipo 3 su macchina con cave a T da 18mm: Art.296 T.3 X=18mm
Oppure con codice: 2.29.6200 X=18mm
Order example for Type 3 vise on machine with 18mm T-slots: Art.296 T.3 X=18mm
Also with code: 2.29.6200 X=18mm

Staffaggio Consigliato
Suggested fixing

Consigliate 3 coppie di staffe Art.296 per ogni morsa

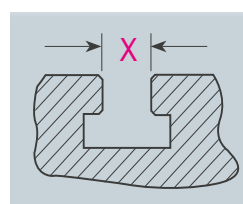
Suggested 3 pairs of holding clamps Art.296 for each vise

Cava a T
T Slot

Specificare sempre la cava della vostra macchina

Always specify the machine T-slot dimension

Ref N° Pag.4.34

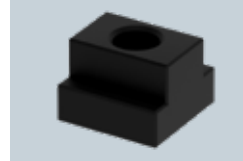
Art.287
Dadi a T - T Nuts

Per fissaggio morse alle cave a T della macchina

For vise clamping on the machine T-slots

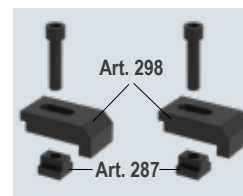
Art.296
(Art.298 + Art.287)

Consigliate 3 coppie di staffe Art.296 per ogni morsa

Suggested 3 pairs of holding clamps Art.296 for each vise

Tipo (grandezza) Type (size)	1				1								2 - 3								
Art. 296	Cava a T slot X	12	14	16	18	12*	14	16	16	18	20	18*	20	22	16	18	20	22	18*	20	22
	T-nuts Ref. N°	8	9	10	11	12	13	14	20	21	22	32	33	34	20	21	33	34	32	33	34
Coppia di staffe Holding clamps pair	Filetto vite Screw thread	M8				M10		M12 *		M16		M12		M16 *							
1 X M8 	A	50				50		50		50		76		76							
	B	24				24		24		24		30		30							
	C	6				6		6		6		6		6							
	Ø D	8,5				11		13		17		13		17							
	E	10				10		10		10		13		13							
	Ø F	14				-		-		-		-		-							
	G / G1	14				16/15		17,5/13		19/9		17/22		16/15							
	H	34				34		34		34		42		42							
	I	8				10		10		10		-		-							
	J	4				4		4		4		10		10							
T ± 0,1	15				15		15		15		20		20								
	Cod.	2.29.61000 / M8				2.29.61000 / M10		2.29.61000 / M12		2.29.61000 / M16		2.29.63000 / M12		2.29.63000 / M12							

* Scelta consigliata - Suggested choice

* Scelta NON consigliata - NOT Suggested choice

Soluzioni personalizzate / Customized solutions

MULTIFLEX

Soluzioni personalizzate a tutti i vostri problemi di serraggio

Customized solutions for all your clamping problems



Morse Multiflex montate verticalmente

Multiflex vises vertically mounted

Cubo portapezzi Art.53C con 8 morse Multiflex Art.606 2x600 montato su Matura H.Plus 400 per serraggio di 32 pezzi

Tombstone Art.53C with 8 Multiflex vises Art.606 2x600 mounted on Matura H.Plus 400 for 32 pcs clamping



Morse Multiflex

Multiflex vises

Morse Multiflex montate in parallelo su centro di lavoro verticale per serraggi multipli

Multiflex vises mounted in parallel on vertical machining centre for multiple clamping



Cubo Multiflex

Multiflex vise tower

Particolari fuori dimensione, ma lavorati su cubo Multiflex Art.607 tipo 2

Rather big work-pieces machined on a Multiflex vise tower Art.607 Type 2



Morse Multiflex su quarto asse

Multiflex vises on 4th axis

Morsa Multiflex con relativa piastra di interfaccia montata su quarto asse

Multiflex vise with interface plate assembled on 4th axis



Morse Multiflex

Multiflex vises

Morse Multiflex Art.611 Tipo 1x700mm con ganasce doppie montate su centro di lavoro HAAS per serraggio di 2 particolari, uno fuori dimensione ed uno molto più piccolo

Multiflex vises Art.611 Type 1x700mm with double jaws shown on Haas machining centre for 2 workpieces clamping, one rather big and the other much smaller.

GUIDA RAPIDA

Per la scelta della morsa Multiflex più adatta alle vostre esigenze

Tipo (grandezza) morsa / Vise type (size)

Art. 600 Art. 600W

Art. 600S

 Ogni morsa è completa di
 1 ganascia fissa,
 4 ganasce fisse-mobili

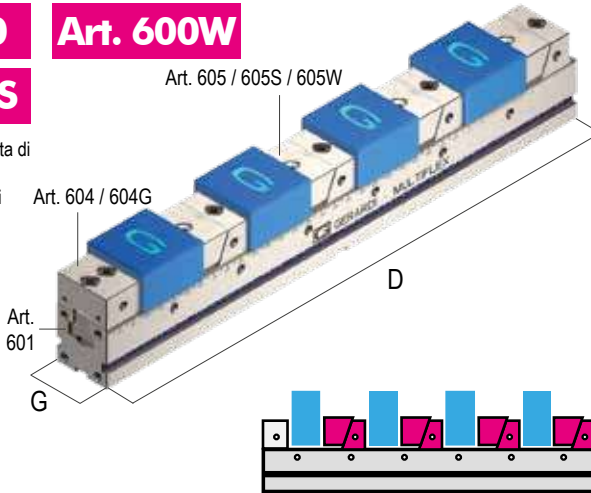
 Each vise is
 supplied with
 1 fixed jaw and
 4 fixed-movable
 jaws

 Per particolari in appoggio sulla base
 For workpieces clamped directly on vise base

 Apertura max in relazione al numero dei particolari
 Max opening according to workpieces to be clamped

kN	1		
	20 kN		
D	300	400	500
$G_{-0.02}^0$	50	50	50
1 pezzo / piece	205	305	408
2 pezzi / pieces	75	125	175
3 pezzi / pieces	30	64	96
4 pezzi / pieces	8	33	58
5 pezzi / pieces	-	15	35
6 pezzi / pieces	-	3	19
7 pezzi / pieces	-	-	8
8 pezzi / pieces	-	-	-
9 pezzi / pieces	-	-	-
10 pezzi / pieces	-	-	-
11 pezzi / pieces	-	-	-
12 pezzi / pieces	-	-	-
Cod. Art. 600	6.60.01300	6.60.01400	6.60.01500
Cod. Art. 600S	6.60.0S130	6.60.0S140	6.60.0S150
Cod. Art. 600W	6.60.0W130	6.60.0W140	6.60.0W150

Art. 606 Art. 606T

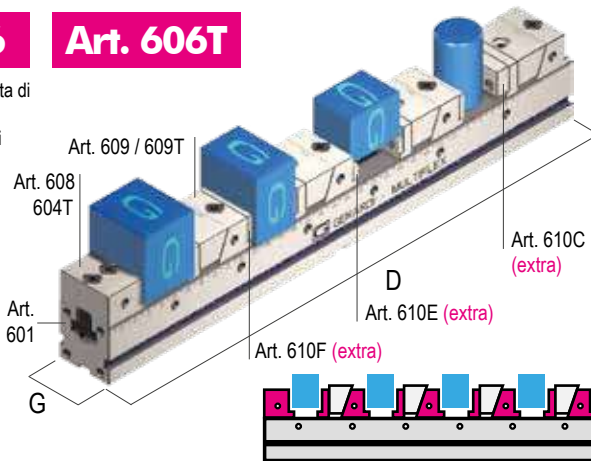
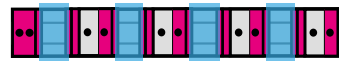
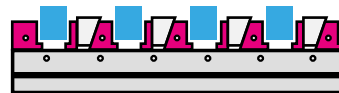
 Ogni morsa è completa di
 1 ganascia fissa,
 4 ganasce fisse-mobili

 Each vise is
 supplied with
 1 fixed jaw and
 4 fixed-movable
 jaws

 Per particolari sollevati per forature passanti
 Rised workpieces for drill through holes

 Apertura max in relazione al numero dei particolari
 Max opening according to workpieces to be clamped

D	300 *	400	500
	$G_{-0.02}^0$		
$G_{-0.02}^0$	50	50	50
1 pezzo / piece	193	293	393
2 pezzi / pieces	63	113	163
3 pezzi / pieces	19	53	86
4 pezzi / pieces	-	23	48
5 pezzi / pieces	-	-	25
6 pezzi / pieces	-	-	-
7 pezzi / pieces	-	-	-
8 pezzi / pieces	-	-	-
9 pezzi / pieces	-	-	-
10 pezzi / pieces	-	-	-
11 pezzi / pieces	-	-	-
12 pezzi / pieces	-	-	-
Cod. Art. 606	6.60.61300	6.60.61400	6.60.61500
Cod. Art. 606T	6.60.6T130	6.60.6T140	6.60.6T150

* Solo per tipo 1 x 300 e 2 x 400 n. 3 ganasce fisse-mobili in dotazione Standaard

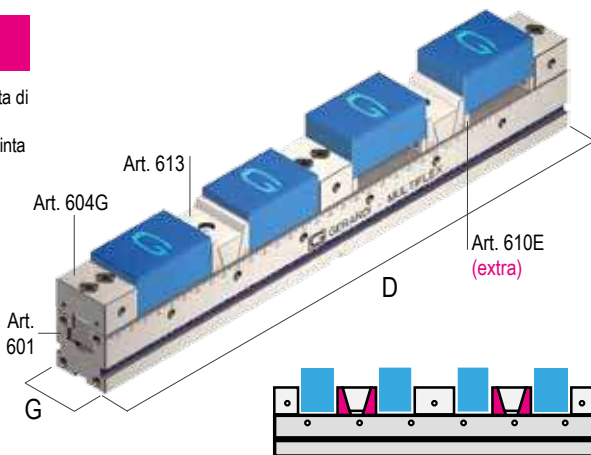
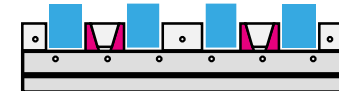
Art. 611

 Ogni morsa è completa di
 3 ganasce fisse,
 2 ganasce mobili di spinta

 Each vise is
 supplied with
 3 fixed jaws
 and 2 clamping
 movable jaws

 Per particolari in appoggio oppure sollevati con parallele
 For workpieces on vise base or rised up with parallels

 Apertura max in relazione al numero dei particolari
 Max opening according to workpieces to be clamped

D	300	400	500
	$G_{-0.02}^0$		
$G_{-0.02}^0$	50	50	50
1 pezzo / piece	174	274	374
2 pezzi / pieces	87	137	185
3 pezzi / pieces	28	62	95
4 pezzi / pieces	21	46	71
5 pezzi / pieces	-	19	39
6 pezzi / pieces	-	16	33
7 pezzi / pieces	-	-	15
8 pezzi / pieces	-	-	13
9 pezzi / pieces	-	-	2
10 pezzi / pieces	-	-	-
11 pezzi / pieces	-	-	-
12 pezzi / pieces	-	-	-
Cod.	6.61.11300	6.61.11400	6.61.11500

QUICK GUIDE

For the proper Multiflex vise choice according to your specific application

D	1 20 kN		2 30 kN						3 40 kN			
	600	700	400	500	600	700	800	900	700	800	900	1000
$G_{-0,02}^0$	50	50	75	75	75	75	75	75	100	100	100	100
1 pcs.	508	608	275	375	475	575	675	755	532	632	732	832
2 pcs.	225	275	100	150	200	250	300	350	217	267	317	367
3 pcs.	129	161	41	75	108	141	175	280	112	145	178	211
4 pcs.	83	108	12	37	62	87	112	137,5	59	84	109	134
5 pcs.	55	75	-	15	35	55	75	95	28	48	68	88
6 pcs.	36	52	-	-	16	33	50	66,5	7	23	39	55
7 pcs.	22	36	-	-	3	17	32	46	-	6	2	34
8 pcs.	12	24	-	-	-	6	18	31	-	-	5	18
9 pcs.	5	16	-	-	-	-	8	19	-	-	-	5
10 pcs.	-	8	-	-	-	-	-	10	-	-	-	-
11 pcs.	-	2	-	-	-	-	-	2	-	-	-	-
12 pcs.	-	-	-	-	-	-	-	-	-	-	-	-
Cod. Art.	6.60.01600	6.60.01700	6.60.02400	6.60.02500	6.60.02600	6.60.02700	6.60.02800	6.60.02900	6.60.03700	6.60.03800	6.60.03900	6.60.03100
Cod. Art.	6.60.0S160	6.60.0S170	6.60.0S240	6.60.0S250	6.60.0S260	6.60.0S270	6.60.0S280	6.60.0S290	6.60.0S370	6.60.0S380	6.60.0S390	6.60.0S310
Cod. Art.	6.60.0W160	6.60.0W170	6.60.0W240	6.60.0W250	6.60.0W260	6.60.0W270	6.60.0W280	6.60.0W290	6.60.0W370	6.60.0W380	6.60.0W390	6.60.0W310

D	600	700	400 *	500	600	700	800	900	700	800	900	1000
$G_{-0,02}^0$	50	50	75	75	75	75	75	75	100	100	100	100
1 pcs.	493	593	262	362	462	562	662	762	512	612	712	812
2 pcs.	213	263	87	137	187	237	287	337	197	247	294	347
3 pcs.	119	152	28	62	95	128	162	195	92	125	158	191
4 pcs.	73	97	-	4 x 27	4 x 52	4 x 77	4 x 102	4 x 127	39	64	89	114
5 pcs.	45	64	-	2	22	42	62	82	8	28	48	68
6 pcs.	26	42	-	-	3	20	37	53,5	-	3	20	37
7 pcs.	13	26	-	-	-	4	19	33	-	-	-	14
8 pcs.	-	14	-	-	-	-	5	18	-	-	-	-
9 pcs.	-	5	-	-	-	-	-	6	-	-	-	-
10 pcs.	-	-	-	-	-	-	-	-	-	-	-	-
11 pcs.	-	-	-	-	-	-	-	-	-	-	-	-
12 pcs.	-	-	-	-	-	-	-	-	-	-	-	-
Cod. Art.	6.60.61600	6.60.61700	6.60.62400	6.60.62500	6.60.62600	6.60.62700	6.60.62800	6.60.62900	6.60.63700	6.60.63800	6.60.63900	6.60.63100
Cod. Art.	6.60.6T160	6.60.6T170	6.60.6T240	6.60.6T250	6.60.6T260	6.60.6T270	6.60.6T280	6.60.6T290	6.60.6T370	6.60.6T380	6.60.6T390	6.60.6T310

* Only for type 1 x 300 and 2 x 400 n. 3 fixed-movable jaws Included in the standard equipment

D	600	700	400	500	600	700	800	900	700	800	900	1000
$G_{-0,02}^0$	50	50	75	75	75	75	75	75	100	100	100	100
1 pcs.	474	574	242	342	442	542	642	792	470	570	670	770
2 pcs.	237	287	121	171	221	271	321	371	235	285	335	285
3 pcs.	128	162	45	78	112	145	178	228	103	136	169	202
4 pcs.	96	121	34	59	84	109	134	158,5	77	102	127	152
5 pcs.	59	79	5	25	45	65	85	115	30	50	70	90
6 pcs.	49	66	-	21	38	54	71	87,5	25	41	57	73
7 pcs.	30	44	-	3	17	31	46	66,5	-	12	26	40
8 pcs.	26	38	-	-	15	27	40	52	-	11	23	35
9 pcs.	13	24	-	-	1	12	23	40	-	-	3	14
10 pcs.	12	22	-	-	-	11	21	31	-	-	-	-
11 pcs.	3	12	-	-	-	-	10	22,5	-	-	-	-
12 pcs.	2	11	-	-	-	-	9	16,5	-	-	-	-
Cod. Art.	6.61.11600	6.61.11700	6.61.12400	6.61.12500	6.61.12600	6.61.12700	6.61.12800	6.61.12900	6.61.13700	6.61.13800	6.61.13900	6.61.13100

GUIDA RAPIDA

Per la scelta della morsa Multiflex piú adatta alle vostre esigenze

GANASCIA Tipo 1 (49mm) su BASE Tipo 2 / JAW Type 1 (49mm) on BASE Type 2
Art. 632
Art. 632W
Art. 632S

 Ogni morsa è completa di
 1 ganascia fissa, 4 ganasce
 fisse-mobili

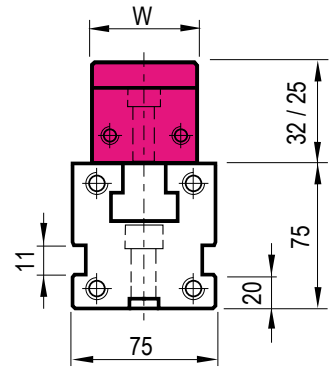
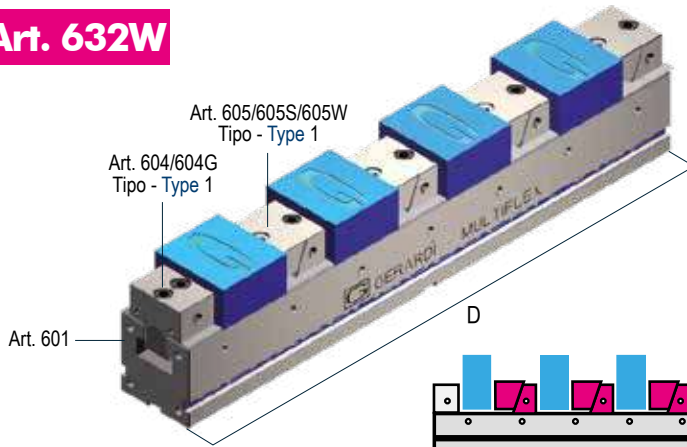
 Each vise is supplied with
 1 fixed jaw and 4 fixed-
 movable jaws

Ganascia tipo 1 ⇒ Base tipo 2
Jaw type 1 ⇒ Base type 2

 Per particolari in appoggio sulla base
 For workpieces clamped directly on vise base

Art. 652
Art. 652T

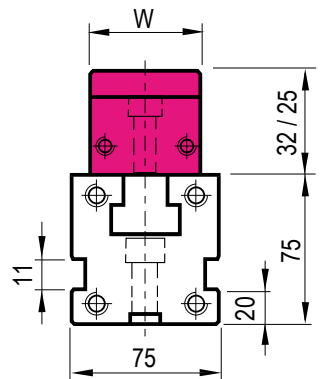
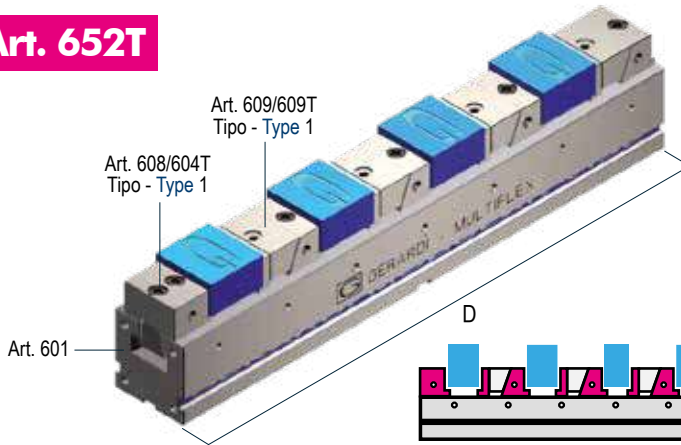
 Ogni morsa è completa di
 1 ganascia fissa,
 4 ganasce fisse-mobili

 Each vise is supplied with
 1 fixed jaw and 4 fixed-movable
 jaws

Ganascia tipo 1 ⇒ Base tipo 2
Jaw type 1 ⇒ Base type 2

 Per particolari sollevati per forature passanti
 Rised workpieces for drill through holes

Art. 692

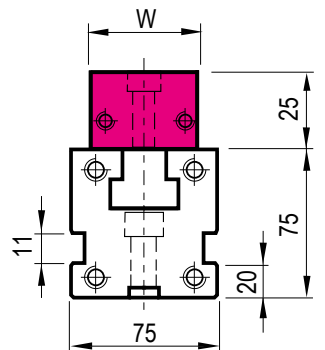
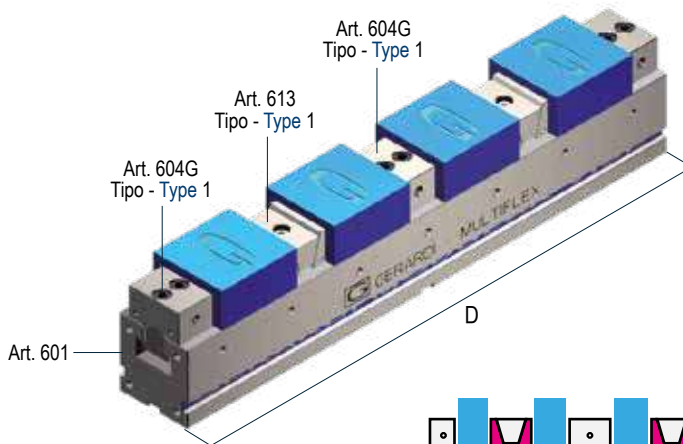
 Ogni morsa è completa di
 3 ganasce fisse, 2 ganasce
 mobili di spinta

 Each vise is supplied with
 3 fixed jaws and 2 clamping
 movable jaws

Ganascia tipo 1 ⇒ Base tipo 2
Jaw type 1 ⇒ Base type 2

 Per particolari in appoggio oppure sollevati con parallele
 For workpieces on vise base or rised up with parallels

QUICK GUIDE

 For the proper Multiflex vise choice according to your specific application

	kN	GANASCIA Tipo 1 - / JAW Type 1					
		20 kN					
	D	400	500	600	700	800	900
Apertura max in relazione al numero dei particolari Max opening according to workpieces to be clamped	1 pezzo / piece	304	404	504	604	704	804
	2 pezzi / pieces	123	173	223	273	323	373
	3 pezzi / pieces	62,7	96	129,3	162,7	196	229,3
	4 pezzi / pieces	32,5	57,5	82,5	107,5	132,5	157,5
	5 pezzi / pieces	14,4	34,4	54,4	74,4	94,4	114,4
	6 pezzi / pieces	2,3	19	35,7	52,3	69	85,7
	7 pezzi / pieces	-	8	22,3	36,6	50,9	65,1
	8 pezzi / pieces	-	-	12,3	24,8	37,3	49,8
	9 pezzi / pieces	-	-	4,4	15,6	26,7	37,8
	10 pezzi / pieces	-	-	-	8,2	18,2	28,2
	11 pezzi / pieces	-	-	-	2,2	11,3	20,4
	12 pezzi / pieces	-	-	-	-	5,5	13,8
	13 pezzi / pieces	-	-	-	-	11,3	8,3
	Cod. Art. 632	6.63.21400	6.63.21500	6.63.21600	6.63.21700	6.63.21800	6.63.21900
	Cod. Art. 632S	6.63.2S140	6.63.2S150	6.63.2S160	6.63.2S170	6.63.2S180	6.63.2S190
	Cod. Art. 632W	6.63.2W140	6.63.2W150	6.63.2W160	6.63.2W170	6.63.2W180	6.63.2W190

	D	400	500	600	700	800	900
2 pezzi / pieces	115	165	215	265	315	365	
3 pezzi / pieces	54,7	88	121,3	154,7	188	221,3	
4 pezzi / pieces	24,5	49,5	74,5	99,5	124,5	149,5	
5 pezzi / pieces	6,4	26,4	46,4	66,4	86,4	106,4	
6 pezzi / pieces	-	11	27,7	44,3	61	77,7	
7 pezzi / pieces	-	-	14,3	28,6	42,9	57,1	
8 pezzi / pieces	-	-	4,3	16,8	29,3	41,8	
9 pezzi / pieces	-	-	-	7,6	18,7	29,8	
10 pezzi / pieces	-	-	-	0,2	10,2	20,2	
11 pezzi / pieces	-	-	-	-	3,3	12,4	
12 pezzi / pieces	-	-	-	-	-	5,8	
	Cod. Art. 652	6.65.21400	6.65.21500	6.65.21600	6.65.21700	6.65.21800	6.65.21900
	Cod. Art. 652T	6.65.2T140	6.65.2T150	6.65.2T160	6.65.2T170	6.65.2T180	6.65.2T190

	D	400	500	600	700	800	900
2 pezzi / pieces	138,5	188,5	238,5	288,5	338,5	388,5	
3 pezzi / pieces	64	97,3	130,7	164	197,3	230,7	
4 pezzi / pieces	48	73	98	123	148	173	
5 pezzi / pieces	21,4	41,4	61,4	81,4	101,4	121,4	
6 pezzi / pieces	17,8	34,5	51,2	67,8	84,5	101,2	
7 pezzi / pieces	3,1	17,4	31,7	46	60,3	74,6	
8 pezzi / pieces	2,8	15,3	27,8	40,3	52,8	65,3	
9 pezzi / pieces	-	4,1	15,2	26,3	37,4	48,6	
10 pezzi / pieces	-	3,7	13,7	23,7	33,7	43,7	
11 pezzi / pieces	-	-	4,7	13,8	22,9	32	
12 pezzi / pieces	-	-	4,3	12,7	21	29,3	
13 pezzi / pieces	-	-	-	5,2	12,8	20,5	
14 pezzi / pieces	-	-	-	1,4	8,6	15,7	
15 pezzi / pieces	-	-	-	-	5,5	12,1	
16 pezzi / pieces	-	-	-	-	2,2	8,4	
17 pezzi / pieces	-	-	-	-	-	5,7	
	Cod.	6.69.21400	6.69.21500	6.69.21600	6.69.21700	6.69.21800	6.69.21900

GUIDA RAPIDA

Per la scelta della morsa Multiflex più adatta alle vostre esigenze

GANASCIA Tipo 1 o Tipo 2 (49 o 74mm) su BASE Tipo 3 / JAW Type 1 or Type 2 (49 o 74mm) on BASE Type 3

Art. 633

Art. 633W

Art. 633S

Ogni morsa è completa di
1 ganascia fissa,
4 ganasce fisse-mobili

Each vise is supplied with
1 fixed jaw and
4 fixed-movable jaws

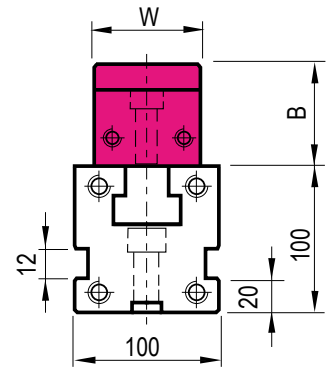
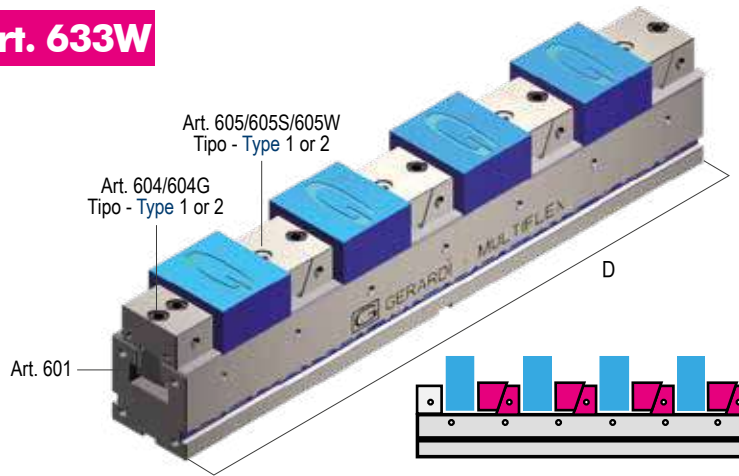

Ganascia tipo 1 o 2 ⇒ Base tipo 3

Jaw type 1 or 2 ⇒ Base type 3



Per particolari in appoggio sulla base
For workpieces clamped directly on vise base

Art. 653

Art. 653T

Ogni morsa è completa di
1 ganascia fissa,
4 ganasce fisse-mobili

Each vise is supplied with
1 fixed jaw and
4 fixed-movable jaws

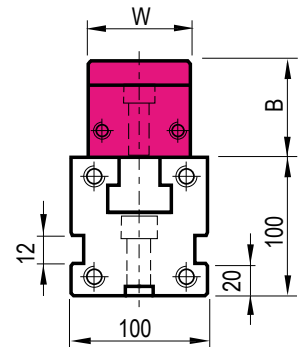
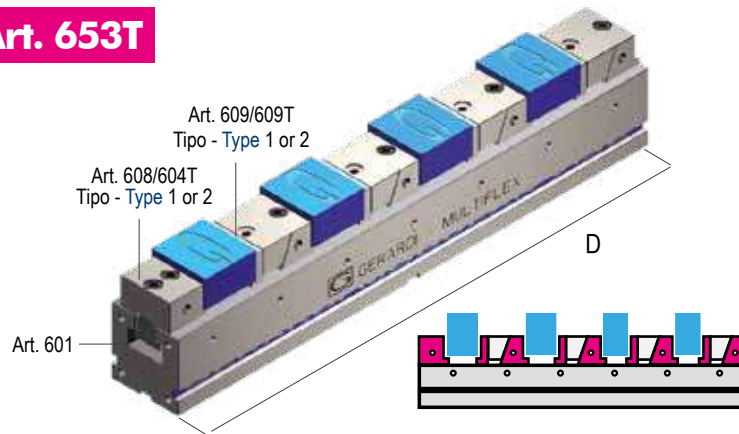

Ganascia tipo 1 o 2 ⇒ Base tipo 3

Jaw type 1 or 2 ⇒ Base type 3



Per particolari sollevati per forature passanti
Rised workpieces for drill through holes

Art. 693

Ogni morsa è completa di
3 ganasce fisse,
2 ganasce mobili di spinta

Each vise is supplied with
3 fixed jaws
and 2 clamping movable jaws

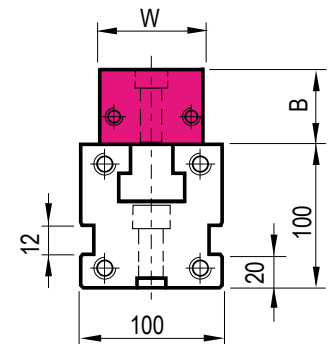
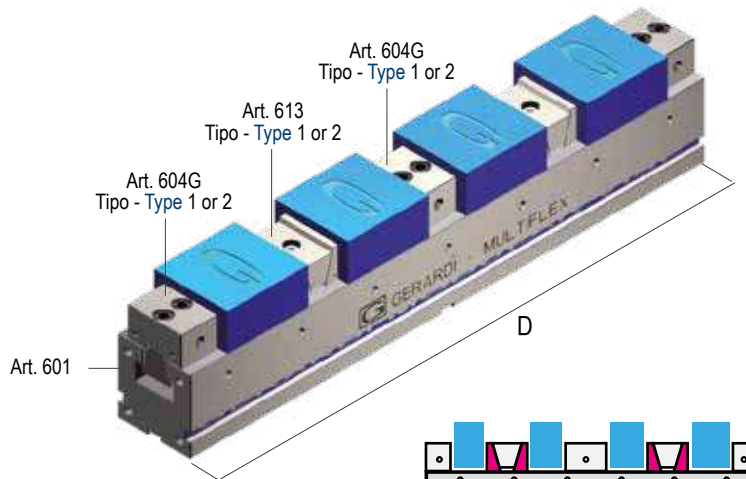

Ganascia tipo 1 o 2 ⇒ Base tipo 3

Jaw type 1 or 2 ⇒ Base type 3



Per particolari in appoggio oppure sollevati con parallele
For workpieces on vise base or rised up with parallels

QUICK GUIDE

For the proper Multiflex vise choice according to your specific application

kN	GANASCIA Tipo 1 - / JAW Type 1				GANASCIA Tipo 2 - / JAW Type 2			
	20 kN				30 kN			
D	700	800	900	1000	700	800	900	1000
W	49				74			
1 pezzo / piece	606	706	806	906	578	678	778	878
2 pezzi / pieces	275	325	375	425	253	303	353	403
3 pezzi / pieces	164,7	198	231,3	264,7	144,7	178	211,3	244,7
4 pezzi / pieces	109,5	134,5	159,5	184,5	90,5	115,5	140,5	165,5
5 pezzi / pieces	76,4	96,4	116,4	136,4	58	78	98	118
6 pezzi / pieces	54,3	71	87,7	104,3	36,3	53	69,7	86,3
7 pezzi / pieces	38,6	52,9	67,1	81,4	20,9	35	49,4	63,7
8 pezzi / pieces	26,8	39,3	51,8	64,3	9,3	21,8	34,3	46,8
9 pezzi / pieces	17,6	28,7	39,8	50,9	-	11,3	22,4	33,6
10 pezzi / pieces	10,2	20,2	30,2	40,2	-	3	13	23
11 pezzi / pieces	4,2	13,3	22,4	31,5	-	-	5,3	14,4
12 pezzi / pieces	-	7,5	15,8	24,2	-	-	-	7,2
13 pezzi / pieces	-	2,6	10,3	18	-	-	-	-
14 pezzi / pieces	-	-	5,6	12,7	-	-	-	-
15 pezzi / pieces	-	-	1,5	8,1	-	-	-	-
Cod. Art. 633	6.63.31700	6.63.31800	6.63.31900	6.63.31100	6.63.32700	6.63.32800	6.63.32900	6.63.32100
Cod. Art. 633S	6.63.3S170	6.63.3S180	6.63.3S190	6.63.3S110	6.63.3S270	6.63.3S280	6.63.3S290	6.63.3S210
Cod. Art. 633W	6.63.3W170	6.63.3W180	6.63.3W190	6.63.3W110	6.63.3W270	6.63.3W280	6.63.3W290	6.63.3W210

kN	GANASCIA Tipo 1 - / JAW Type 1				GANASCIA Tipo 2 - / JAW Type 2			
	20 kN				30 kN			
D	700	800	900	1000	700	800	900	1000
W	49				74			
1 pezzo / piece	596	696	796	896	565	665	765	865
2 pezzi / pieces	265	315	365	415	240	290	340	390
3 pezzi / pieces	154,7	188	221,3	254,7	131,7	165	198,3	231,7
4 pezzi / pieces	99,5	124,5	149,5	174,5	77,5	102,5	127,5	152,5
5 pezzi / pieces	66,4	86,4	106,4	126,4	45	65	85	105
6 pezzi / pieces	44,3	61	77,7	94,3	23,3	40	56,7	73,3
7 pezzi / pieces	28,6	42,9	57,1	71,4	7,9	22,1	36,4	50,7
8 pezzi / pieces	16,8	29,3	41,8	54,3	-	8,8	21,3	33,8
9 pezzi / pieces	7,6	18,7	29,8	40,9	-	-	9,4	20,6
10 pezzi / pieces	-	10,2	20,2	30,2	-	-	-	10
11 pezzi / pieces	-	3,3	12,4	21,5	-	-	-	-
12 pezzi / pieces	-	-	5,8	14,2	-	-	-	-
13 pezzi / pieces	-	-	-	8	-	-	-	-
Cod. Art. 653	6.65.31700	6.65.31800	6.65.31900	6.65.31100	6.65.32700	6.65.32800	6.65.32900	6.65.32100
Cod. Art. 653T	6.65.3T170	6.65.3T180	6.65.3T190	6.65.3T110	6.65.3T270	6.65.3T280	6.65.3T290	6.65.3T210

kN	GANASCIA Tipo 1 - / JAW Type 1				GANASCIA Tipo 2 - / JAW Type 2			
	20 kN				30 kN			
D	700	800	900	1000	700	800	900	1000
W	49				74			
1 pezzo / piece	577	677	777	877	545	645	745	845
2 pezzi / pieces	288,5	338,5	388,5	438,5	272	322,5	372,5	422,5
3 pezzi / pieces	164	197,3	230,7	264	146,7	180	213	246,7
4 pezzi / pieces	123	148	173	198	110	135	160	185
5 pezzi / pieces	81,4	101,4	121,4	141,4	67	87	107	127
6 pezzi / pieces	67,8	84,5	101,2	117,8	55,8	72,5	89,2	105,8
7 pezzi / pieces	46	60,3	74,6	88,9	32,9	47,1	61,4	75,7
8 pezzi / pieces	40,3	52,8	65,3	77,8	28,8	41,3	53,8	66,3
9 pezzi / pieces	26,3	37,4	48,6	59,7	13,9	25	36,1	47,2
10 pezzi / pieces	23,7	33,7	43,7	53,7	12,5	22,5	32,5	42,5
11 pezzi / pieces	13,8	22,9	32	41,1	-	10,9	20	29,1
12 pezzi / pieces	12,7	21	29,3	37,7	-	10	18,3	26,7
13 pezzi / pieces	5,2	12,8	20,5	28,2	-	-	8,8	16,5
14 pezzi / pieces	1,4	8,6	15,7	22,9	-	-	4,3	11,4
15 pezzi / pieces	-	5,5	12,1	18,8	-	-	-	7,3
16 pezzi / pieces	-	2,2	8,4	14,7	-	-	-	3,4
17 pezzi / pieces	-	-	5,7	11,6	-	-	-	-
18 pezzi / pieces	-	-	-	8,3	-	-	-	-
19 pezzi / pieces	-	-	-	5,9	-	-	-	-
Cod.	6.69.31700	6.69.31800	6.69.31900	6.69.31100	6.69.32700	6.69.32800	6.69.32900	6.69.32100

 Apertura max in relazione al numero dei particolari
 Max opening according to workpieces to be clamped

 Apertura max in relazione al numero dei particolari
 Max opening according to workpieces to be clamped

 Apertura max in relazione al numero dei particolari
 Max opening according to workpieces to be clamped

Tipo (grandezza) morsa / Vise type (size)

- Art.600** Morsa con ganasce lisce (Art. 605)
Vise with smooth jaws (Art. 605)
- Art.600S** Con ganasce zigrinate (Art. 605S)
With serrated jaws (Art. 605S)
- Art.600W** Con ganasce mobili lisce e fisse zigrinate (Art.605W)
With smooth movable jaw and fixed serrated jaws (Art.605W)

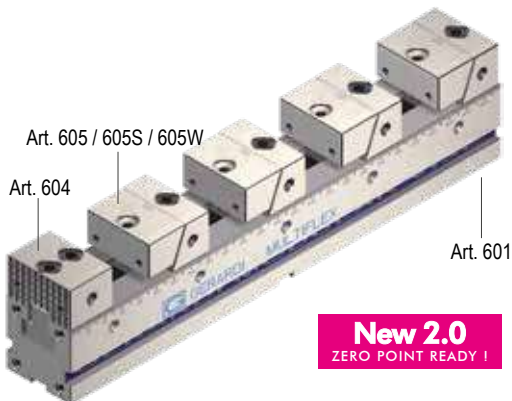

New 2.0
ZERO POINT READY !

Per particolari in appoggio sulla base
For workpieces clamped directly on vise base

kN	1				
	20 kN				
A	4 x 8mm	4 x 33	4 x 58	4 x 83	4 x 108
B	32 / 25				
C ⁰ / _{-0,02}	50				
D ⁰ / _{-0,05}	300	400	500	600	700
G ⁰ / _{-0,02}	50				
J	38				
J1	55 / 58				
I	10				
F	15				
W	49				
ØP	9				
Q ^{±0,02}	100 / 200	100 / 200	200	300	400
kg	7,2	8,7	10,1	11,6	13
Cod. Art. 600	6.60.01300	6.60.01400	6.60.01500	6.60.01600	6.60.01700
Cod. Art. 600S	6.60.0S130	6.60.0S140	6.60.0S150	6.60.0S160	6.60.0S170
Cod. Art. 600W	6.60.0W130	6.60.0W140	6.60.0W150	6.60.0W160	6.60.0W170

AMPLIA LE TUE APPLICAZIONI TRAMITE GLI ACCESSORI MODULARI !
Art. 604*

Ganascia fissa (1 lato liscia, 1 lato zigrinato)
Fixed jaw (1 side smooth, 1 side serrated)

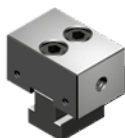

Cod. 6.60.41000

* Arresto laterale a richiesta - Workstop on request

Art. 605*

Ganascia mobile e fissa liscia
Fixed and movable smooth jaws

Art. 605S*

Ganascia mobile e fissa zigrinata
Fixed and movable serrated jaws



Cod. Art.605 6.60.51000

Cod. Art.605S 6.60.5S100

* Arresto laterale a richiesta - Workstop on request

Art. 605L

Cuneo di spinta a "V"
"V" clamping wedge

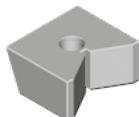

Cod. 6.60.5L100

Art. 615*

Ganascia con cuneo di posizionamento maggiorato
Jaw with bigger positioning wedge
(increased with respect to standard dimensions)

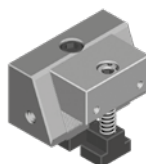

Cod. 6.61.51000

* Arresto laterale a richiesta - Workstop on request

Art. 600
Art. 600S
Art. 600W

Dotazione standard:

- 4 arresti laterali Art. 370
- 1 coppia di tasselli di posizionamento per cava da 16 mm Art. 297
- 1 chiave a T Art. 376

Extra per ogni foro aggiuntivo per Zero Point

**Art. 600 - Art. 600S
Art. 600W**

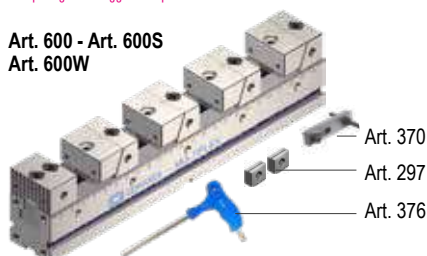

Standard equipment:

- 4 workstops Art. 370
- 1 pair of positioning key-nuts for 16 mm slot Art. 297
- 1 T-wrench Art. 376

Extra charge for each hole for Zero Point

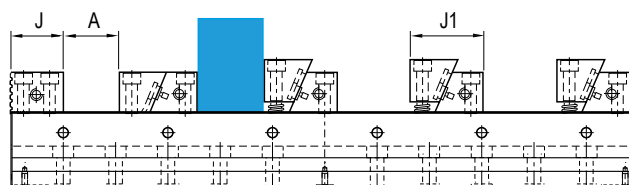
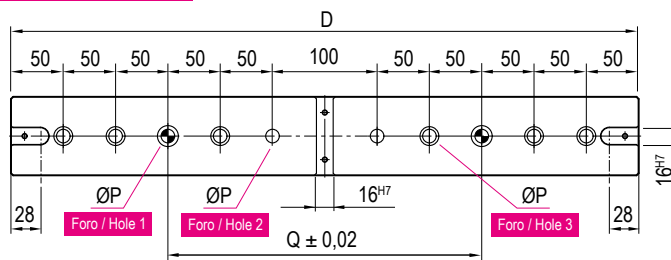

Fori per Zero Point Holes for Zero Point	Foro - Hole 1
Fori per fissaggio morsa Holes for vise clamping	Foro - Hole 2
	Foro - Hole 3

Vedi Pag - See Page 6.30

	2 30 kN						3 40 kN			
A	4 x 12mm	4 x 37	4 x 62	4 x 87	4 x 112	4x137	4 x 59	4 x 84	4 x 109	4 x 134
B	40						60			
C ⁰ _{-0,02}	75						100			
D ⁰ _{-0,05}	400	500	600	700	800	900	700	800	900	1000
G ⁰ _{-0,02}	75						100			
J	50						70			
J1	70 / 75						94,5 / 98,5			
I	11						12			
F	20						20			
W	74						99			
P	13						17			
Q ^{±0,02}	200 / 300	200	300	400	400 / 500	300 / 400 / 500	400	400 / 500	400 / 500	400 / 500
kg	22,45	25,95	29,45	32,95	36,4	39,9	65,1	70,6	77,6	83,3
Cod. Art. 600	6.60.02400	6.60.02500	6.60.02600	6.60.02700	6.60.02800	6.60.02900	6.60.03700	6.60.03800	6.60.03900	6.60.03100
Cod. Art. 600S	6.60.0S240	6.60.0S250	6.60.0S260	6.60.0S270	6.60.0S280	6.60.0S290	6.60.0S370	6.60.0S380	6.60.0S390	6.60.0S310
Cod. Art. 600W	6.60.0W240	6.60.0W250	6.60.0W260	6.60.0W270	6.60.0W280	6.60.0W290	6.60.0W370	6.60.0W380	6.60.0W390	6.60.0W310

UPGRADE YOUR VISE APPLICATIONS THROUGH MODULAR ACCESSORIES !

Cod.	6.60.42000	6.60.43000
Cod. Art.605	6.60.52000	6.60.53000
Cod. Art.605S	6.60.5S200	6.60.5S300
Cod.	6.60.5L200	6.60.5L300
Cod.	6.61.52000	6.61.53000

Art. 605
**GANASCIA LISCIA
JAW PLATE**

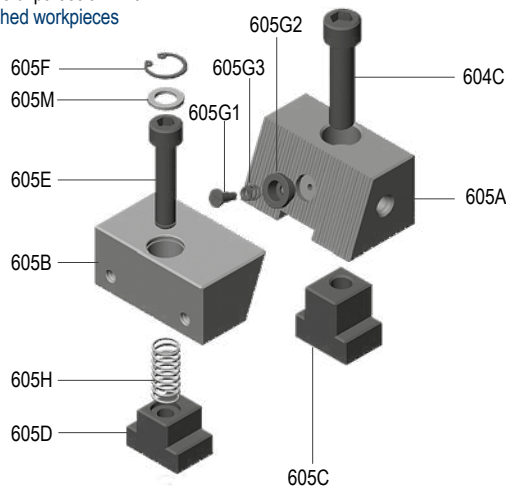
 Per il serraggio di particolari finiti
 To clamp finished workpieces

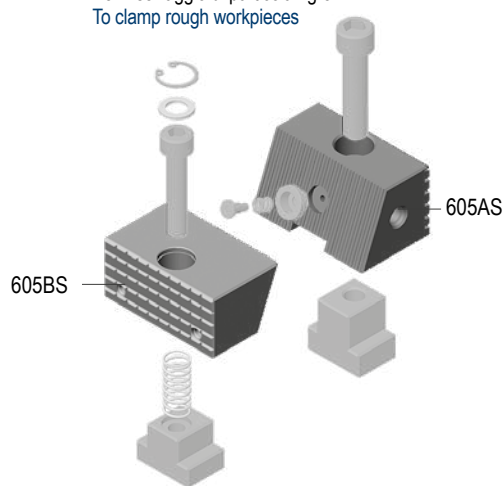
Art. 605S
**GANASCIA ZIGRINATA
SERRATED JAW**

 Per il serraggio di particolari grezzi
 To clamp rough workpieces

Art.	Pag.
601	6.30
604	6.32
605	6.33
605S	6.33
605A	6.35
605AS	6.35
605B	6.35
605BS	6.35
604C	6.35
605C	6.35
605D	6.35
605E	6.35
605F	6.35
605G1	6.35
605G2	6.35
605G3	6.35
605H	6.35
605M	6.35

Tipo (grandezza) morsa / Vise type (size)
Art.606

 Morsa con ganasce a gradino (Art. 609)
 Vise with step jaws (Art. 609)

Art.606T

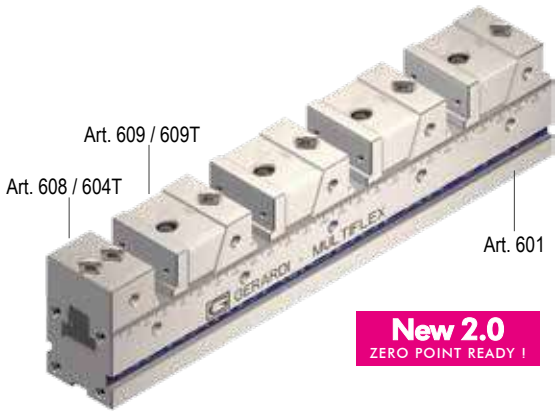
 Morsa con ganasca **GRIP** (Art. 609T)
 Vise with **GRIP** jaws (Art. 609T)

kN	1				
	20 kN				
A (606)	3 x 19mm*	4 x 23	4 x 48	4 x 73	4 x 97
A1 (606T)	3 x 15,3mm	4 x 18,8	4 x 43,8	4 x 68,8	4 x 93,8
B	32 / 25				
C $\begin{matrix} 0 \\ -0,02 \end{matrix}$	50				
D $\begin{matrix} 0 \\ -0,05 \end{matrix}$	300	400	500	600	700
G $\begin{matrix} 0 \\ -0,02 \end{matrix}$	50				
J	38				
J1	65 / 68				
I	10				
F	15				
W	49				
ØP	9				
Q $\pm 0,02$	100 / 200	100 / 200	200	300	400
kg	7,25	8,8	10,2	11,7	13,15
Cod. Art. 606	6.60.61300	6.60.61400	6.60.61500	6.60.61600	6.60.61700
Cod. Art. 606T	6.60.6T130	6.60.6T140	6.60.6T150	6.60.6T160	6.60.6T170

 Per particolari sollevati per forature passanti
 Rised workpieces for drill through holes

* Solo tipo 1 x 300 e 2 x 400 n. 3 ganasce fisse-mobili in dotazione

AMPLIA LE TUE APPLICAZIONI TRAMITE GLI ACCESSORI MODULARI !
Art. 609*

 Ganasca fissa e mobile con gradino
 Fixed and moving jaw with step

Cod. 6.60.91000

* Arresto laterale a richiesta - Workstop on request

Art. 610B

Piastra ganasca lavorabile / Soft jaw plate



Cod. Art. 610B 6.61.0B100

Art. 610C

Piastra ganasca liscia / Smooth jaw plate



Cod. Art. 610C 6.61.0C100

Art. 610D

Piastra ganasca zigrinata / Serrated jaw plate



Cod. Art. 610D 6.61.0D100

Art. 610E

Piastra ganasca parallela / Parallel jaw plate



Cod. Art. 610E 6.61.0E100

Art. 610F

Piastra ganasca prismatica / Prismatic jaw plate



Cod. Art. 610F 6.61.0F100

Piastrine Art.610B - 610C - 610D - 610E - 610F dimensioni come pagina 6.36 - Jaw plates Art.610B - 610C - 610E - 610F dimensions as page 6.36

Art. 609T*

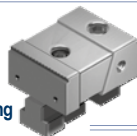
 Ganasca fissa e mobile con piastra ganasca **GRIP a forte serraggio**
 Fixed and moving jaw with **GRIP** jaw-plates for strongest clamping

Cod. 6.60.9T100

* Arresto laterale a richiesta - Workstop on request

Art. 606
Art. 606T

Dotazione standard:

- 4 arresti laterali Art. 370
- 1 coppia di tasselli di posizionamento per cava da 16 mm Art. 297
- 1 chiave a T Art. 376

Extra per ogni foro aggiuntivo per Zero Point

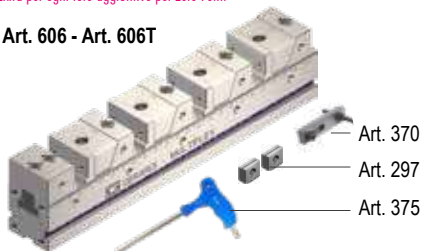
Art. 606 - Art. 606T

Standard equipment:

- 4 workstops Art. 370
- 1 pair of positioning key-nuts for 16 mm slot Art. 297
- 1 T-wrench Art. 376

Extra charge for each hole for Zero Point

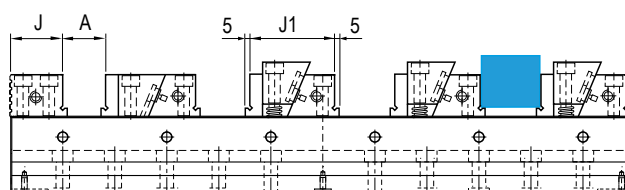
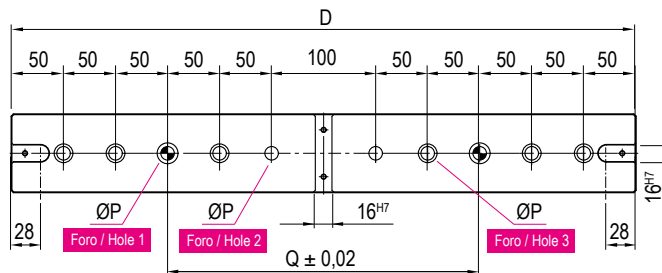

Fori per Zero Point Holes for Zero Point	Foro - Hole 1
Fori per fissaggio morsa Holes for vise clamping	Foro - Hole 2
	Foro - Hole 3

Vedi Pag - See Page 6.30

	2 30 kN						3 40 kN			
A (606)	3 x 31mm*	4 x 27	4 x 52	4 x 77	4 x 102	4 x 127	4 x 44	4 x 69	4 x 94	4 x 119
A1 (609T)	3 x 28mm	4 x 24	4 x 49	4 x 74	4 x 99	4 x 124	4 x 41,5	4 x 66,5	4 x 91,5	4 x 116,5
B	40						60			
C ⁰ _{-0,02}	75						100			
D ⁰ _{-0,05}	400	500	600	700	800	900	700	800	900	1000
G ⁰ _{-0,02}	75						100			
J	50						70			
J1	83 / 88						113 / 119			
I	11						12			
F	20						20			
W	74						99			
P	13						17			
Q ^{±0,02}	200 / 300	200	300	400	400 / 500	300 / 400 / 500	400	400 / 500	400 / 500	400 / 500
kg	21,9	25,4	28,9	32,4	38,1	41,6	68,3	73,8	81	86,5
Cod. Art. 606	6.60.62400	6.60.62500	6.60.62600	6.60.62700	6.60.62800	6.60.62900	6.60.63700	6.60.63800	6.60.63900	6.60.63100
Cod. Art. 606T	6.60.6T240	6.60.6T250	6.60.6T260	6.60.6T270	6.60.6T280	6.60.6T290	6.60.6T370	6.60.6T380	6.60.6T390	6.60.6T310

* Only type 1 x 300 and 2 x 400 n. 3 fixed-movable jaws included

UPGRADE YOUR VISE APPLICATIONS THROUGH MODULAR ACCESSORIES !

Cod.	6.60.92000	6.60.93000
Cod. Art. 610B	6.61.0B200	6.61.0B300
Cod. Art. 610C	6.61.0C200	6.61.0C300
Cod. Art. 610D	6.61.0D200	6.61.0D300
Cod. Art. 610E	6.61.0E200	6.61.0E300
Cod. Art. 610F	6.61.0F200	6.61.0F300

Piastri Art.610B - 610C - 610D - 610E - 610F dimensioni come pagina 6.36 - Jaw plates Art.610B - 610C - 610E - 610F dimensions as page 6.36

Cod.	6.60.9T200	6.60.9T300

Art. 609

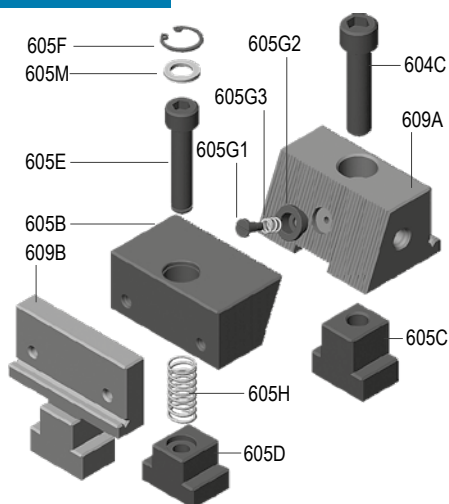

Art. 609T

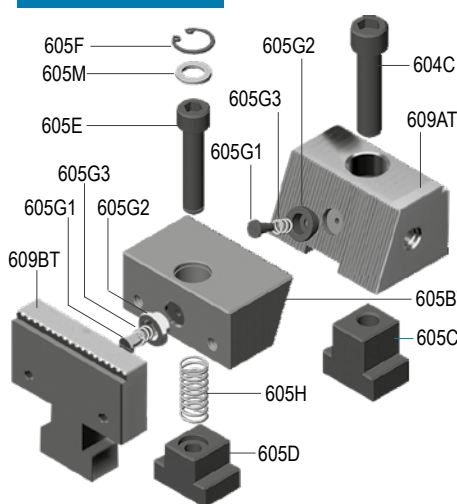

Art.	Pag.	Art.	Pag.
601	6.30	605G3	6.35
604C	6.35	605H	6.35
604T	6.32	605M	6.35
605B	6.35	608	6.32
605BT	6.36	609A	6.36
605C		609	6.16
605D		609B	6.36
605E	6.35	609AT	6.36
605F		609BT	6.36
605G1		609T	6.16
605G2			

* Quota J1 valida solo per Art. 609
J1 dimension valids only for Art. 609

* Quota J2 valida solo per Art. 609T
J2 dimension valids only for Art. 609T

Tipo (grandezza) morsa / Vise type (size)
Art.611

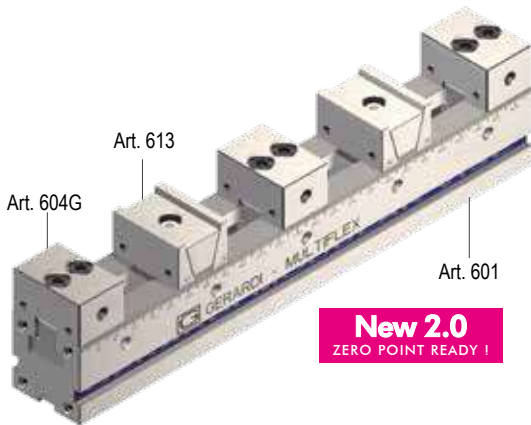
 Morsa con ganasce doppie (Art. 613)
 Vise with double clamping jaws (Art. 613)

kN	1				
	20 kN				
A	4 x 21mm	4 x 46	4 x 71	4 x 94	4 x 121
B			25		
C $0_{-0,02}$			50		
D $0_{-0,05}$	300	400	500	600	700
G $0_{-0,02}$			50		
J			38		
J1			44 / 50		
I			10		
F			15		
W			49		
ØP			9		
Q $\pm 0,02$	100 / 200	100 / 200	200	300	400
kg	6,6	8,1	9,5	11	12,5
Cod.	6.61.11300	6.61.11400	6.61.11500	6.61.11600	6.61.11700

 Per particolari in appoggio oppure sollevati con parallele
 For workpieces on vise base or rised up with parallels

AMPLIA LE TUE APPLICAZIONI TRAMITE GLI ACCESSORI MODULARI !
Art. 604G*

 Ganasca fissa liscia da entrambi i lati
 Fixed smooth jaws both sides

Cod. 6.60.4G100

* Arresto laterale a richiesta - Workstop on request

Art. 610B

Piastra ganascia lavorabile / Soft jaw plate



Cod. Art. 610B 6.61.0B100

Art. 610C

Piastra ganascia liscia / Smooth jaw plate



Cod. Art. 610C 6.61.0C100

Art. 610D

Piastra ganascia zigrinata / Serrated jaw plate



Cod. Art. 610D 6.61.0D100

Art. 610E

Piastra ganascia parallela / Parallel jaw plate



Cod. Art. 610E 6.61.0E100

Art. 610F

Piastra ganascia prismatica / Prismatic jaw plate



Cod. Art. 610F 6.61.0F100

Piastrine Art.610B - 610C - 610D - 610E - 610F dimensioni come pagina 6.36 - Jaw plates Art.610B - 610C - 610E - 610F dimensions as page 6.36

Art. 613

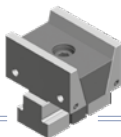
 Ganasca mobile doppia di spinta
 Double clamping movable jaws

Cod. 6.61.31000

Art. 611

- Dotazione standard:
- 4 arresti laterali Art. 370
 - 1 coppia di tasselli di posizionamento per cava da 16 mm Art. 297
 - 1 chiave a T Art. 376

Extra per ogni foro aggiuntivo per Zero Point

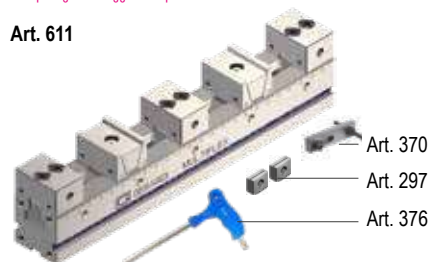
Art. 611

- Standard equipment:
- 4 workstops Art. 370
 - 1 pair of positioning key-nuts for 16 mm slot Art. 297
 - 1 T-wrench Art. 376

Extra charge for each hole for Zero Point

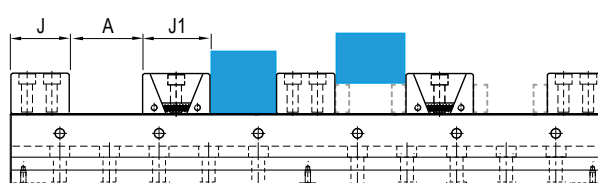
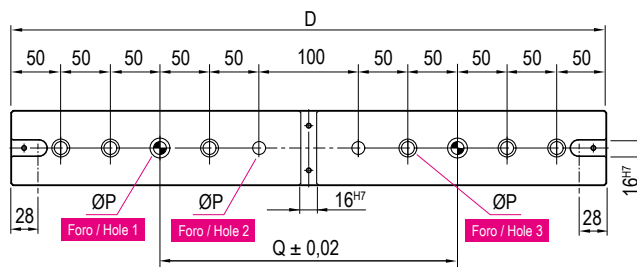

Fori per Zero Point Holes for Zero Point	Foro - Hole 1
Fori per fissaggio morsa Holes for vise clamping	Foro - Hole 2
	Foro - Hole 3

Vedi Pag - See Page 6.30

	2 30 kN						3 40 kN			
A	4 x 34	4 x 59	4 x 84	4 x 109	4 x 134	4x159	4 x 77	4 x 102	4 x 127	4 x 152
B	40						60			
C ⁰ _{-0,02}	75						100			
D ⁰ _{-0,05}	400	500	600	700	800	900	700	800	900	1000
G ⁰ _{-0,02}	75						100			
J	50						70			
J1	52 / 58						84 / 90			
I	11						12			
F	20						20			
W	74						99			
ØP	13						17			
Q ^{±0,02}	200 / 300	200	300	400	400 / 500	300 / 400 / 500	400	400 / 500	400 / 500	400 / 500
kg	20,79	24,29	27,79	31,29	34,8	38,3	63	68,5	74	79,5
Cod. Art. 606	6.61.12400	6.61.12500	6.61.12600	6.61.12700	6.61.12800	6.61.12900	6.61.13700	6.61.13800	6.61.13900	6.61.13100

UPGRADE YOUR VISE APPLICATIONS THROUGH MODULAR ACCESSORIES !

Cod.	6.60.4G200	6.60.4G300
Cod. Art. 610B	6.61.0B200	6.61.0B300
Cod. Art. 610C	6.61.0C200	6.61.0C300
Cod. Art. 610D	6.61.0D200	6.61.0D300
Cod. Art. 610E	6.61.0E200	6.61.0E300
Cod. Art. 610F	6.61.0F200	6.61.0F300

Piastrine Art.610B - 610C - 610D - 610E - 610F dimensioni come pagina 6.36 - Jaw plates Art.610B - 610C - 610E - 610F dimensions as page 6.36

Cod.	6.61.32000	6.61.33000

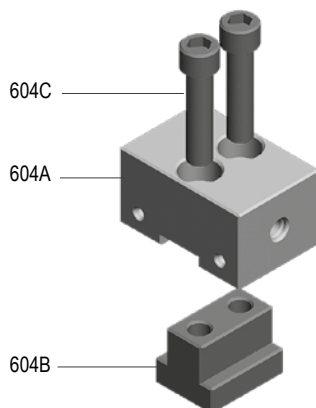
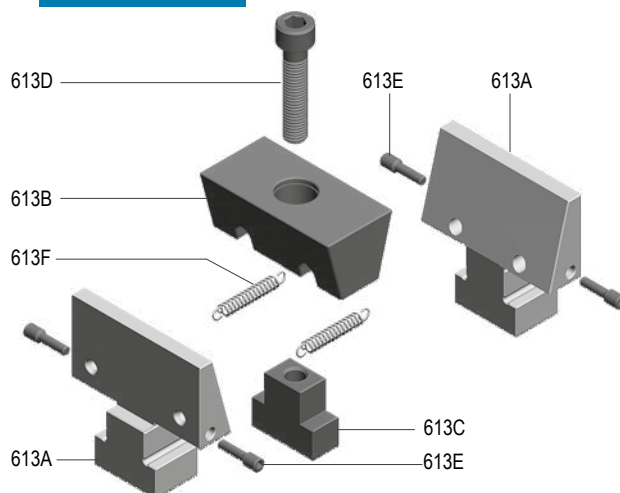
Art. 604G
GANASCIA FISSA
FIXED JAW

Art. 613
GANASCIA DOPPIA
DOUBLE JAW

Art.	Pag.
601	6.30
604A	6.35
604B	6.35
604C	6.35
604G	6.32
613	6.34
613A	6.37
613B	6.37
613C	6.37
613D	6.37
613E	6.37
613F	6.37

GANASCE TIPO 1 ⇒ BASE TIPO 2

JAWS TYPE 1 ⇒ BASE TYPE 2

Art. 632 Morsa con ganasce lisce (Art. 605)
Vise with smooth jaws (Art. 605)

Art. 632S Morsa con ganasce zigrinate (Art. 605S)
Vise with serrated jaws (Art. 605S)

Art. 632W Morsa con ganasca mobile liscia e fissa zigrinata (Art. 605W)
Vise with smooth movable jaws and fixed serrated jaws (Art. 605W)

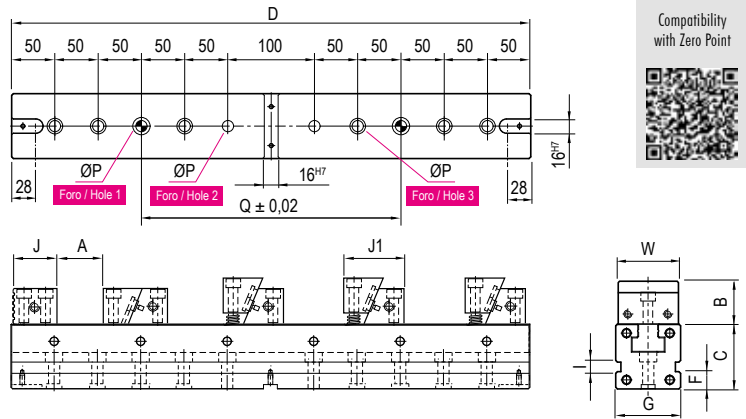
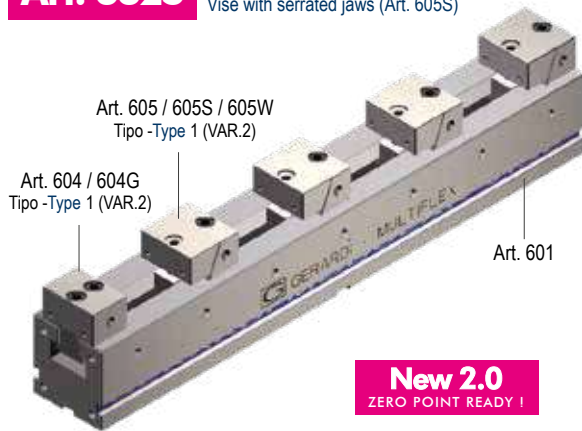

Compatibilità con Zero Point
Compatibility with Zero Point



Per particolari in appoggio sulla base
For workpieces clamped directly on vise base

Specificare quota W in fase d'ordine - To be specify the W quote in case of order

Art. 652 Morsa con ganasce a gradino (Art. 609)
Vise with step jaws (Art. 609)

Art. 652T Morsa con ganasce GRIP (Art. 609T)
Vise with GRIP jaws (Art. 609T)

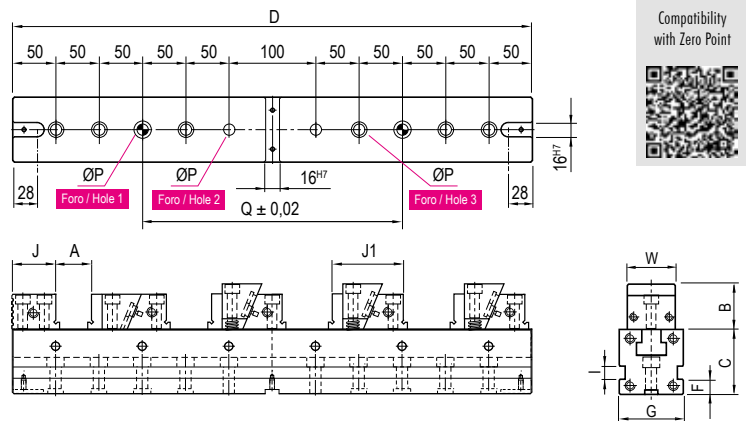
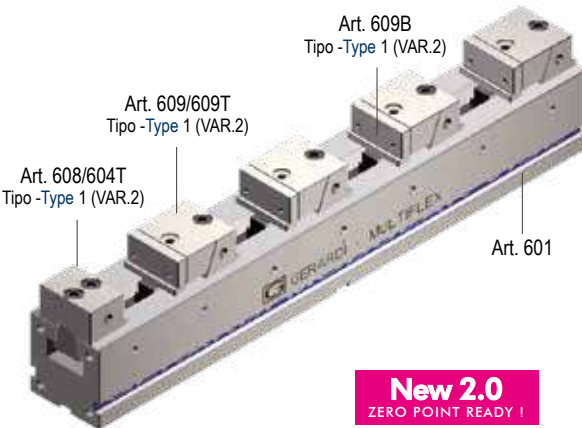

Compatibilità con Zero Point
Compatibility with Zero Point



Per particolari sollevati per forature passanti
Rised workpieces for drill through holes

Specificare quota W in fase d'ordine - To be specify the W quote in case of order

Art. 692 Morsa con ganasce doppie (Art. 613)
Vise with double jaws (Art. 613)

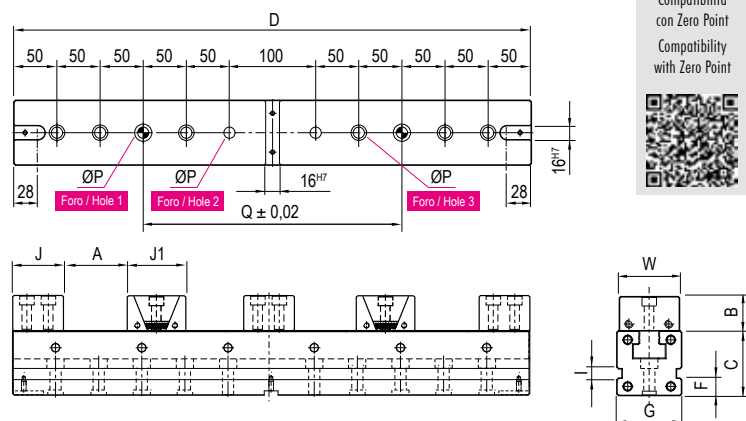
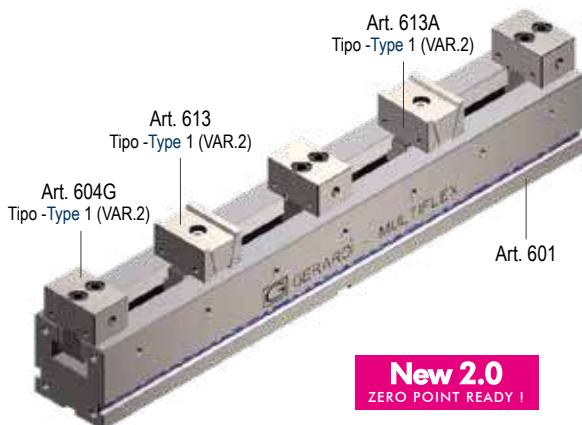

Compatibilità con Zero Point
Compatibility with Zero Point



Per particolari in appoggio oppure sollevati con parallele
For workpieces on vise base or rised up with parallels

Specificare quota W in fase d'ordine - To be specify the W quote in case of order

1 20 kN						
A	4 x 32,5	4 x 57,5	4 x 82,5	4 x 107,5	4 x 132,5	4 x 157,5
B	32 / 25					
C ^{0 -0,02}	75					
D ^{0 -0,05}	400	500	600	700	800	900
G ^{0 -0,02}	75					
J	38					
J1	55 / 58					
I	11					
F	20					
W	49					
ØP	13					
Q ^{±0,02}	200 / 300	200	300	400	400 / 500	300 / 400 / 500
kg	16,7	20,2	23,7	27,2	30,7	34,2
Cod. Art. 632	6.63.21400	6.63.21500	6.63.21600	6.63.21700	6.63.21800	6.63.21900
Cod. Art. 632S	6.63.2S140	6.63.2S150	6.63.2S160	6.63.2S170	6.63.2S180	6.63.2S190
Cod. Art. 632W	6.63.2W140	6.63.2W150	6.63.2W160	6.63.2W170	6.63.2W180	6.63.2W190

Extra per ogni foro aggiunto per Zero Point

Extra charge for each hole for Zero Point

Kit trasformazione ganasce
 Jaws transformations kit

Art. 604B T.1 (VAR.2)

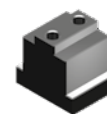
 Dado a "T" per ganasce fissa
 "T" nut for fixed jaw

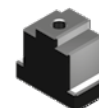
Art. 605C T.1 (VAR.2)

 Dado a "T" per cuneo di posizionamento
 "T" nut for positioning wedge

Art. 605D T.1 (VAR.2)

 Dado a "T" per cuneo di spinta
 "T" nut for clamping wedge

Vedi pag 6.38 - See pag 6.38

A	4 x 24,5	4 x 49,5	4 x 74,5	4 x 99,5	4 x 124,5	4 x 149,5
B	32 / 25					
C ^{0 -0,02}	75					
D ^{0 -0,05}	400	500	600	700	800	900
G ^{0 -0,02}	75					
J	38					
J1	65 / 68					
F	11					
F	20					
W	49					
ØP	13					
Q ^{±0,02}	200 / 300	200	300	400	400 / 500	300 / 400 / 500
kg	16,8	20,3	23,8	27,3	30,8	34,3
Cod. Art.652	6.65.21400	6.65.21500	6.65.21600	6.65.21700	6.65.21800	6.65.21900
Cod. Art.652T	6.65.2T140	6.65.2T150	6.65.2T160	6.65.2T170	6.65.2T180	6.65.2T190

Extra per ogni foro aggiunto per Zero Point

Extra charge for each hole for Zero Point

Art. 609B T.1 (VAR.2)

 Ganasce mobile guidata con gradino
 Movable guided jaw with step

Art. 604B T.1 (VAR.2)

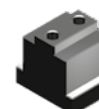
 Dado a "T" per ganasce fissa
 "T" nut for fixed jaw

Art. 605C T.1 (VAR.2)

 Dado a "T" per cuneo di posizionamento
 "T" nut for positioning wedge

Art. 605D T.1 (VAR.2)

 Dado a "T" per cuneo di spinta
 "T" nut for clamping wedge

Vedi pag 6.36-38 - See pag 6.36-38

A	4 x 48	4 x 73	4 x 98	4 x 123	4 x 148	4 x 173
B	25					
C ^{0 -0,02}	75					
D ^{0 -0,05}	400	500	600	700	800	900
G ^{0 -0,02}	75					
J	38					
J1	44 / 50					
I	11					
F	20					
W	49					
ØP	13					
Q ^{±0,02}	200 / 300	200	300	400	400 / 500	300 / 400 / 500
kg	16,1	19,6	23,1	26,6	30,1	33,7
Cod.	6.69.21400	6.69.21500	6.69.21600	6.69.21700	6.69.21800	6.69.21900

Extra per ogni foro aggiunto per Zero Point

Extra charge for each hole for Zero Point

Art. 613A T.1 (VAR.2)

 Ganasce mobile
 Movable jaw

Art. 604B T.1 (VAR.2)

 Dado a "T" per ganasce fissa
 "T" nut for fixed jaw

Vedi pag 6.37-38 - See pag 6.37-38

GANASCE TIPO 1 o 2 ⇒ BASE TIPO 3

JAWS TYPE 1 or 2 ⇒ BASE TYPE 3

Art. 633

Morsa con ganasce lisce (Art. 605)
Vise with smooth jaws (Art. 605)

Art. 633S

Morsa con ganasce zigrinate (Art. 605S)
Vise with serrated jaws (Art. 605S)

Art. 633W

Morsa con ganascia mobile liscia e fissa zigrinata (Art. 605W)
Vise with smooth movable jaws and fixed serrated jaws (Art. 605W)

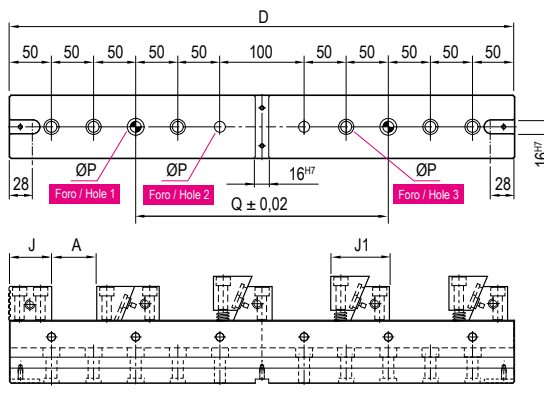
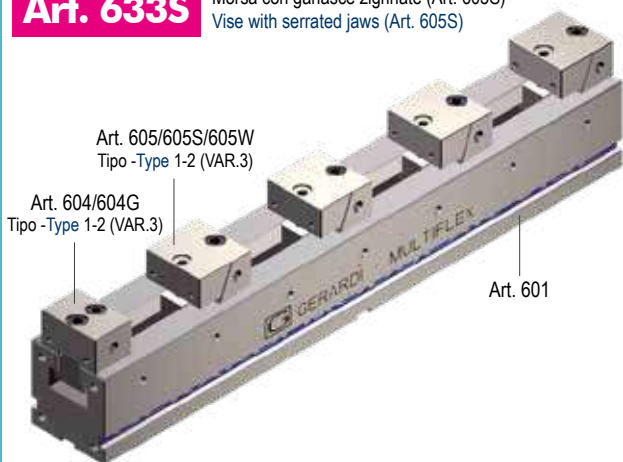

Compatibilità con Zero Point
Compatibility with Zero Point

Per particolari in appoggio sulla base
For workpieces clamped directly on vise base

Specificare quota W in fase d'ordine - To be specify the W quote in case of order

Art. 653

Morsa con ganasce a gradino (Art. 609)
Vise with step jaws (Art. 609)

Art. 653T

Morsa con ganasce GRIP (Art. 609T)
Vise with GRIP jaws (Art. 609T)

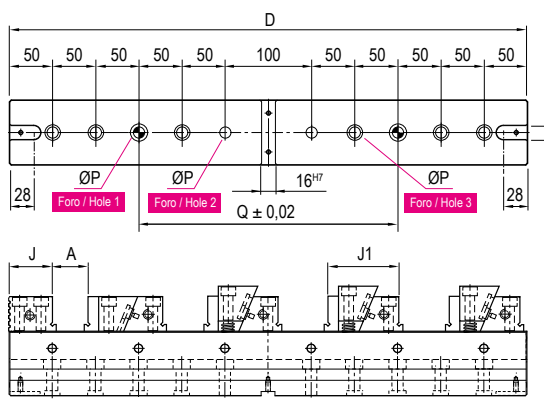
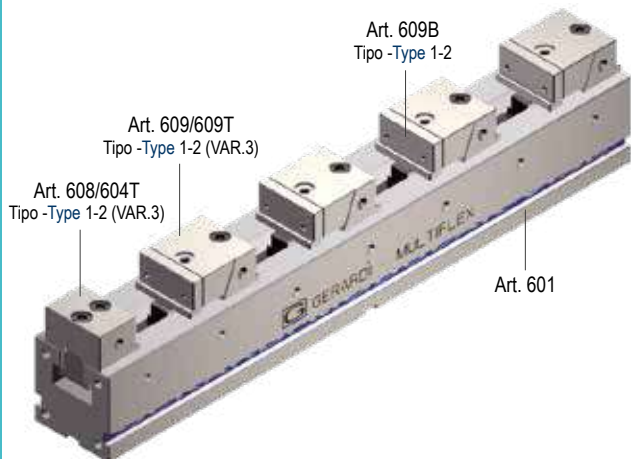

Compatibilità con Zero Point
Compatibility with Zero Point

Per particolari sollevati per forature passanti
Rised workpieces for drill through holes

Specificare quota W in fase d'ordine - To be specify the W quote in case of order

Art. 693

Morsa con ganasce doppie (Art. 613)
Vise with double jaws (Art. 613)

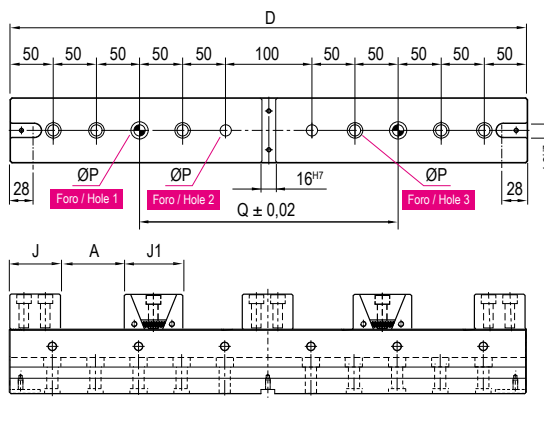
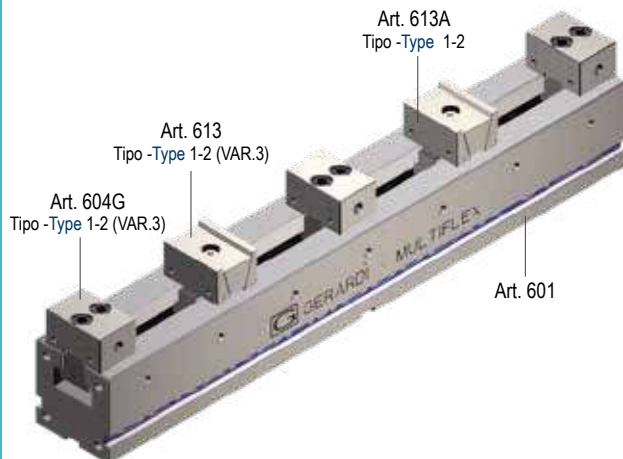

Compatibilità con Zero Point
Compatibility with Zero Point

Per particolari in appoggio oppure sollevati con parallele
For workpieces on vise base or rised up with parallels

Specificare quota W in fase d'ordine - To be specify the W quote in case of order

	1 20 kN				2 30 kN			
	A	4 x 109,5	4 x 134,5	4 x 159,5	4 x 184,5	4 x 90,5	4 x 115,5	4 x 140,5
B	32 / 25				40			
C ^{0 -0,02}	100				100			
D ^{0 -0,05}	700	800	900	1000	700	800	900	1000
G ^{0 -0,02}	100				100			
J	38				50			
J1	55 / 58				70 / 25			
I	12				12			
F	20				20			
W	49				74			
ØP	17				17			
Q ^{±0,02}	400	400 / 500	400 / 500	400 / 500	400	400 / 500	400 / 500	400 / 500
kg	45,3	50,8	57,8	63,5	50,5	56	63	68,7
Cod. Art. 633	6.63.31700	6.63.31800	6.63.31900	6.63.31100	6.63.32700	6.63.32800	6.63.32900	6.63.32100
Cod. Art. 633S	6.63.3S170	6.63.3S180	6.63.3S190	6.63.3S110	6.63.3S270	6.63.3S280	6.63.3S290	6.63.3S210
Cod. Art. 633W	6.63.3W170	6.63.3W180	6.63.3W190	6.63.3W110	6.63.3W270	6.63.3W280	6.63.3W290	6.63.3W210

Extra per ogni foro aggiunto per Zero Point

Extra charge for each hole for Zero Point

Vedi pag 6.38 - See pag 6.38

	1				2			
	A	4 x 99,5	4 x 124,5	4 x 149,5	4 x 174,5	4 x 77,5	4 x 102,5	4 x 127,5
B	32 / 25				40			
C ^{0 -0,02}	100				100			
D ^{0 -0,05}	700	800	900	1000	700	800	900	1000
G ^{0 -0,02}	100				100			
J	38				50			
J1	65 / 68				83 / 88			
I	12				12			
F	20				20			
W	49				74			
ØP	17				17			
Q ^{±0,02}	400	400 / 500	400 / 500	400 / 500	400	400 / 500	400 / 500	400 / 500
kg	45,4	50,9	57,9	63,6	51,1	56,6	63,6	69,3
Cod. Art. 653	6.65.31700	6.65.31800	6.65.31900	6.65.31100	6.65.32700	6.65.32800	6.65.32900	6.65.32100
Cod. Art. 653T	6.65.3T170	6.65.3T180	6.65.3T190	6.65.3T110	6.65.3T270	6.65.3T280	6.65.3T290	6.65.3T210

Extra per ogni foro aggiunto per Zero Point

Extra charge for each hole for Zero Point

Vedi pag 6.36-38 - See pag 6.36-38

	1				2			
	A	4 x 123	4 x 148	4 x 173	4 x 198	4 x 110	4 x 135	4 x 160
B	25				40			
C ^{0 -0,02}	100				100			
D ^{0 -0,05}	700	800	900	1000	700	800	900	1000
G ^{0 -0,02}	100				100			
J	38				50			
J1	44 / 50				52 / 58			
I	12				12			
F	20				20			
W	49				74			
ØP	17				17			
Q ^{±0,02}	400	400 / 500	400 / 500	400 / 500	400	400 / 500	400 / 500	400 / 500
kg	44,7	50,2	57,9	62,9	49,4	54,9	61,9	66,6
Cod.	6.69.31700	6.69.31800	6.69.31900	6.69.31100	6.69.32700	6.69.32800	6.69.32900	6.69.32100

Extra per ogni foro aggiunto per Zero Point

Extra charge for each hole for Zero Point

Vedi pag 6.37-38 - See pag 6.37-38

Kit trasformazione ganasce
 Jaws transformations kit

Art. 604B T.1 (VAR.2)

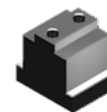
 Dado a "T" per
 ganascia fissa
 "T" nut for
 fixed jaw

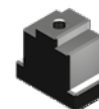
Art. 605C T.1 (VAR.2)

 Dado a "T" per
 cuneo di
 posizionamento
 "T" nut for
 positioning wedge

Art. 605D T.1 / (VAR.2)

 Dado a "T" per
 cuneo di spinta
 "T" nut for
 clamping wedge

Art. 609B T.1 (VAR.2)

 Ganascia mobile
 guidata con gradino
 Movable guided
 jaw with step

Art. 604B T.1 (VAR.2)

 Dado a "T" per
 ganascia fissa
 "T" nut for
 fixed jaw

Art. 605C T.1 (VAR.2)

 Dado a "T" per
 cuneo di
 posizionamento
 "T" nut for
 positioning wedge

Art. 605D T.1 (VAR.2)

 Dado a "T" per
 cuneo di spinta
 "T" nut for
 clamping wedge

Art. 613A T.1 (VAR.2)

 Ganascia mobile
 Movable jaw

Art. 604B T.1 (VAR.2)

 Dado a "T" per
 ganascia fissa
 "T" nut for
 fixed jaw



Tipo (grandezza) morsa / Vise type (size)
Art. 602

 Cubo-morsa con ganasce lisce (Art. 605)
 Vise-tower with smooth jaws (Art. 605)

Art. 602S

 Cubo-morsa con ganasce zigrinate (Art. 605S)
 Vise-tower with serrated jaws (Art. 605S)

Art. 602W

 Cubo-morsa con ganasce mobili lisce e
 fisse zigrinate (Art. 605W)
 Vise cube with smooth movable jaw and
 fixed serrated jaws (Art. 605W)

 Ogni cubo-morsa è completo di 4 ganasce fisse, 16 ganasce fisse mobili,
 1 chiave a T, 1 coppia tasselli di posizionamento per cava da 16mm e 16
 arresti laterali

 Each vise-tower is supplied with 4 fixed jaws and
 16 fixed-movable jaws, 1 T wrench, 1 pair of
 positioning key-nuts for 16 mm slot Art. 297 and 16 workstops

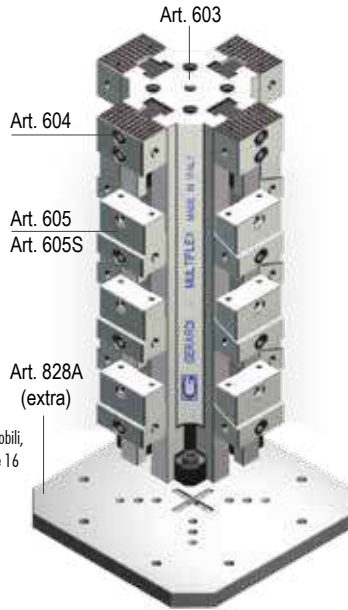
Per particolari in appoggio sulla base
For workpieces clamped directly on vise base

kN	1				
	20 kN				
A	4 x 8mm	4 x 33	4 x 58	4 x 83	4 x 108
B	25				
B1	32 / 25				
C ⁻⁰ _{-0,02}	100				
D	300	400	500	600	700
G ⁻⁰ _{-0,02}	50				
J	38				
J1	55 / 58				
H	66				
Ø I ^{H7}	25				
L	20				
M	14				
kg	26,2	31,2	36,2	41,2	46,3
Cod. Art.602	6.60.21300	6.60.21400	6.60.21500	6.60.21600	6.60.21700
Cod. Art.602S	6.60.2S130	6.60.2S140	6.60.2S150	6.60.2S160	6.60.2S170
Cod. Art.602W	6.60.2W130	6.60.2W140	6.60.2W150	6.60.2W160	6.60.2W170

AMPLIA LE TUE APPLICAZIONI TRAMITE GLI ACCESSORI MODULARI !
Art. 604*

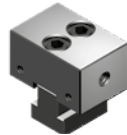
 Ganasca fissa (1 lato liscia, 1 lato zigrinata)
 Fixed jaw (1 side smooth, 1 side serrated)

Cod. 6.60.41000

* Arresto laterale a richiesta - Workstop on request

Art. 605*

 Ganasca mobile
 e fissa liscia
 Fixed and movable
 smooth jaws

Art. 605S*

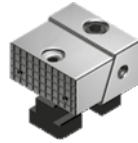
 Ganasca mobile
 e fissa zigrinata
 Fixed and movable
 serrated jaws

Cod. Art.605 6.60.51000

Cod. Art.605S 6.60.5S100

* Arresto laterale a richiesta - Workstop on request

Art. 605L

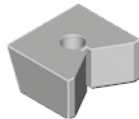
 Cuneo di spinta a "V"
 "V" clamping wedge

Cod. 6.60.5L100

Art. 615*

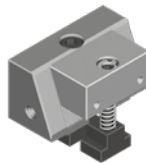
 Ganasca con cuneo di posizionamento maggiorato
 Jaw with bigger positioning wedge
 (increased with respect to standard dimensions)

Cod. 6.61.51000

* Arresto laterale a richiesta - Workstop on request

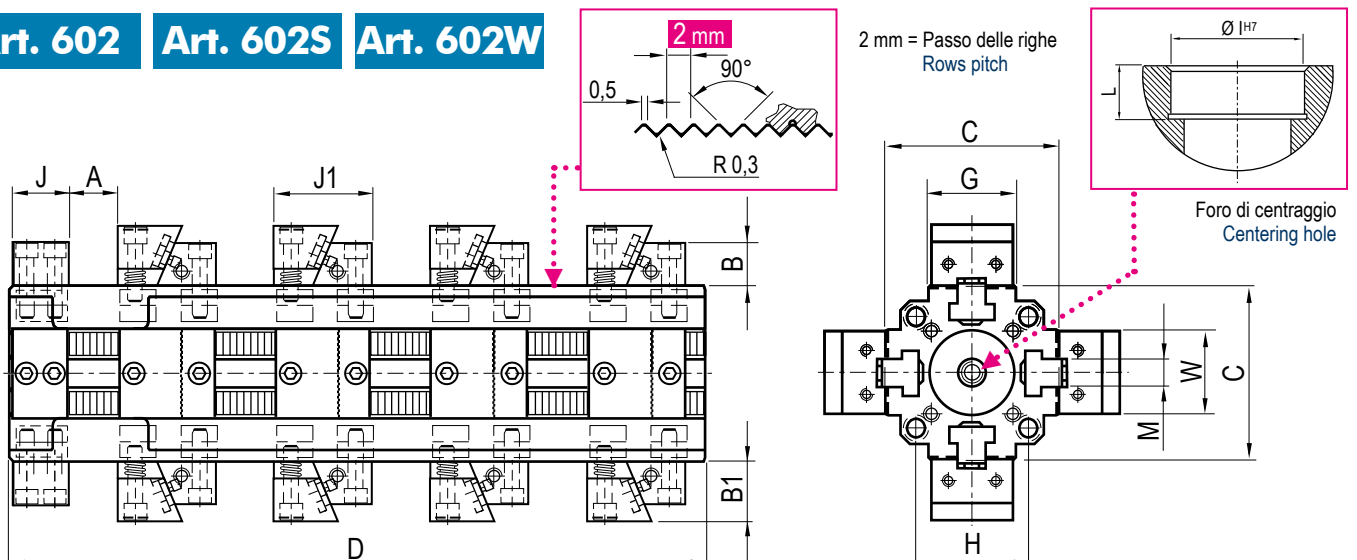
Art. 602 Art. 602S Art. 602W

2 30 kN						3 40 kN						
A	4 x 12mm	4 x 37	4 x 62	4 x 62	4 x 87	4 x 87	4 x 87	4 x 112	4 x 59	4 x 84	4 x 109	4 x 134
B		40		40	40		40			60		
B1		40		40	40		40			60		
C ⁻⁰ _{-0,02}		150		230	150	210	240			240		
D	400	500	600	600	700	700	700	800	700	800	900	1000
G ⁻⁰ _{-0,02}		75		75	75		75			100		
J		50		50	50		50			70		
J1		70 / 75		70 / 75	70 / 75		70 / 75			94,5 / 98,5		
H		100		-	100	100	-	-		150 / 200		
Ø I ^{H7}		50		50	50		50			50		
L		20		20	20		20			20		
M		22		22	22		22			30		
kg	79	90,2	101,4	144	112,6	149,2	175	195	254	278	301	325
Cod. Art.	6.60.22400	6.60.22500	6.60.22600	6.60.22601	6.60.22700	6.60.22701	6.60.22702	6.60.22800	6.60.23700	6.60.23800	6.60.23900	6.60.23100
Cod. Art.	6.60.2S240	6.60.2S250	6.60.2S260	6.60.2S261	6.60.2S270	6.60.2S271	6.60.2S272	6.60.2S280	6.60.2S370	6.60.2S380	6.60.2S390	6.60.2S310
Cod. Art.	6.60.2W240	6.60.2W250	6.60.2W260	6.60.2W261	6.60.2W270	6.60.2W271	6.60.2W272	6.60.2W280	6.60.2W370	6.60.2W380	6.60.2W390	6.60.2W310

I prezzi su fondo magenta sono **comprensivi di base integrale** / Prices on the magenta background include the solid head plate with the vise-tower

UPGRADE YOUR VISE APPLICATIONS THROUGH MODULAR ACCESSORIES !

6.60.42000

6.60.43000

6.60.52000

6.60.53000

6.60.5S200

6.60.5S300

6.60.5L200

6.60.5L300

6.61.52000

6.61.53000

Art. 605
**GANASCIA LISCIA
JAW PLATE**

Per il serraggio di particolari finiti
To clamp finished workpieces

Art. 605W

Ganascia mobile liscia e fissa zigrinata
Smooth movable jaw and fixed serrated jaw

Art. 605S
**GANASCIA ZIGRINATA
SERRATED JAW**

Per il serraggio di particolari grezzi
To clamp rough workpieces

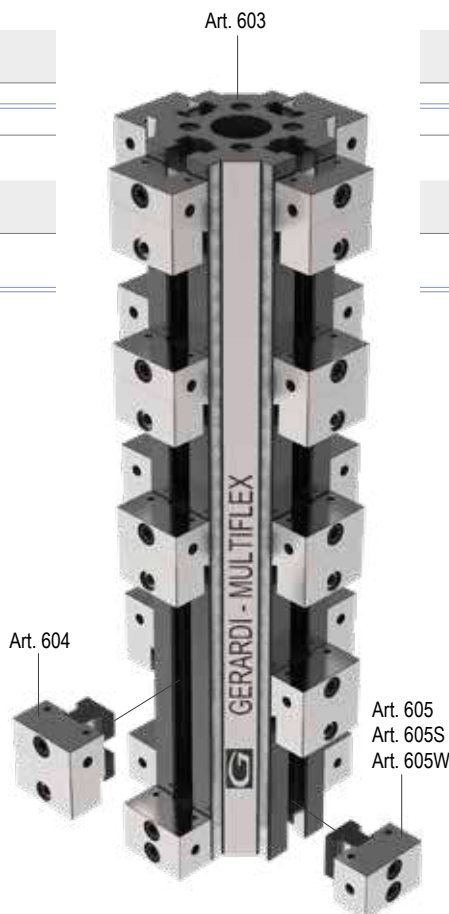

Art.	Pag.
603	6.31
604	6.32
605	6.33
605S	6.33

Tipo (grandezza) morsa / Vise type (size)
kN
1
20 kN
Art. 607

 Cubo-morsa con ganasce a gradino (Art. 609)
 Vise-tower with step jaws (Art. 609)

Art. 607T

 Cubo-morsa con ganasce **GRIP** (Art. 609T)
 Vise-tower with **GRIP** jaws (Art. 609T)

 Ogni cubo-morsa è completo di 4 ganasce fisse, 16 ganasce fisse mobili,
 1 chiave a T, 1 coppia tasselli di posizionamento per cava da 16mm e
 16 arresti laterali

 Each vise-tower is supplied with 4 fixed jaws and 16 fixed-movable jaws 1
 T wrench, 1 pair of positioning key-nuts for 16 mm slot Art. 297 and 16
 workstops

 * Solo tipo 1x300 e 2x400 n. 12 ganasce fisse-mobili in dotazione
 Only type 1x300 and 2x400 n. 12 fixed-movable jaws included

Art. 828A extra



	3 x 19mm *		4 x 23			4 x 48			4 x 73			4 x 97		
A														
B														
B1														
C ⁻⁰ _{-0.02}														
D	300		400			500			600			700		
G ⁻⁰ _{-0.02}														
J														
J1														
J2														
H														
Ø ^{H7}														
L														
M														
W														
kg	29,6		34,6			39,6			44,6			49,7		
Cod. Art. 607	6.60.71300		6.60.71400			6.60.71500			6.60.71600			6.60.71700		
Cod. Art. 607T	6.60.7T130		6.60.7T140			6.60.7T150			6.60.7T160			6.60.7T170		

 Per particolari sollevati per forature passanti
 Rised workpieces for drill through holes

AMPLIA LE TUE APPLICAZIONI TRAMITE GLI ACCESSORI MODULARI !
Art. 609*

 Ganasca fissa e mobile con gradino
 Fixed and moving jaw with step

Cod. 6.60.91000

* Arresto laterale a richiesta - Workstop on request

Art. 610B

Piastra ganasca lavorabile / Soft jaw plate



Cod. Art. 610B 6.61.0B100

Art. 610C

Piastra ganasca liscia / Smooth jaw plate



Cod. Art. 610C 6.61.0C100

Art. 610D

Piastra ganasca zigrinata / Serrated jaw plate



Cod. Art. 610D 6.61.0D100

Art. 610E

Piastra ganasca parallela / Parallel jaw plate



Cod. Art. 610E 6.61.0E100

Art. 610F

Piastra ganasca prismatica / Prismatic jaw plate



Cod. Art. 610F 6.61.0F100

Piastrine Art.610B - 610C - 610D - 610E - 610F dimensioni come pagina 6.36 - Jaw plates Art.610B - 610C - 610E - 610F dimensions as page 6.36

Art. 609T*

 Ganasca fissa e mobile con piastra ganasca
GRIP a forte serraggio

 Fixed and moving jaw with **GRIP** jaw-plates for strongest clamping

Cod. 6.60.9T100

* Arresto laterale a richiesta - Workstop on request

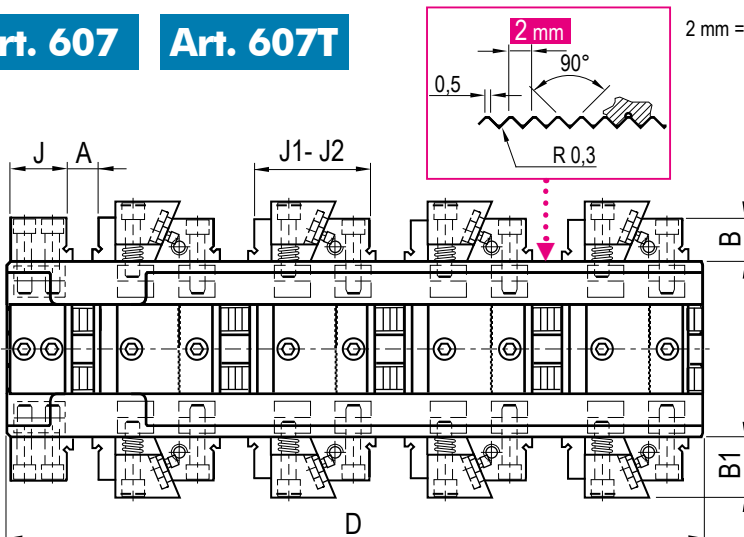
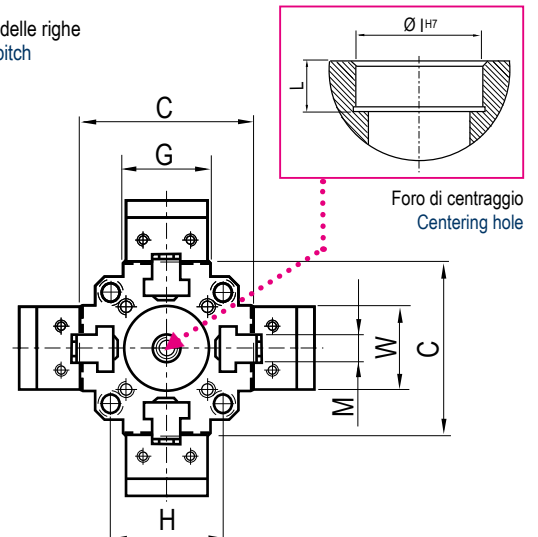
Art. 607
Art. 607T

 2 mm = Passo delle righe
 Rows pitch

 Foro di centraggio
 Centering hole

2 30 kN					3 40 kN							
A	3 x 28mm*	4 x 24	4 x 49	4 x 49	4 x 74	4 x 74	4 x 74	4 x 99	4 x 39	4 x 64	4 x 89	4 x 114
B		40		40	40			40			60	
B1		40		40	40			40			60	
C ^{-0 -0.02}		150		230	150	210		240			240	
D	400	500	600	600	700	700	700	800	700	800	900	1000
G ^{-0 -0.02}		75		75	75			75			100	
J		50		50	50			50			70	
J1		83 / 88		83 / 88	83 / 88			83 / 88			109 / 113	
J2		77 / 82		77 / 82	77 / 82			77 / 82			103 / 107	
H		100		-	100	-	-	-			150 / 200	
Ø I ^{H7}		50		50	50			50			50	
L		20		20	20			20			20	
M		22		22	22			22			30	
W		74		74	74			74			99	
kg	85,6	96,8	108	150	119,2	155,8	183	203	268	292	315	339
Cod. Art.	6.60.72400	6.60.72500	6.60.72600	6.60.72601	6.60.72700	6.60.72701	6.60.72702	6.60.72800	6.60.73700	6.60.73800	6.60.73900	6.60.73100
Cod. Art.	6.60.7T240	6.60.7T250	6.60.7T260	6.60.7T261	6.60.7T270	6.60.7T271	6.60.7T272	6.60.7T280	6.60.7T370	6.60.7T380	6.60.7T390	6.60.7T310

I prezzi su fondo magenta sono **comprensivi di base integrale** / Prices on the magenta background include the solid head plate with the vise-tower

UPGRADE YOUR VISE APPLICATIONS THROUGH MODULAR ACCESSORIES !

Cod.	6.60.92000	6.60.93000
Cod. Art. 610B	6.61.0B200	6.61.0B300
Cod. Art. 610C	6.61.0C200	6.61.0C300
Cod. Art. 610D	6.61.0D200	6.61.0D300
Cod. Art. 610E	6.61.0E200	6.61.0E300
Cod. Art. 610F	6.61.0F200	6.61.0F300

Piastrine Art.610B - 610C - 610D - 610E - 610F dimensioni come pagina 6.36 - Jaw plates Art.610B - 610C - 610E - 610F dimensions as page 6.36

Cod.	6.60.9T200	6.60.9T300
------	------------	------------

Art. 609

Ganascia fissa e mobile con gradino
Fixed and moving jaw with step

Art. 609T

Ganascia fissa e mobile con piastra
ganascia **GRIP a forte serraggio**
Fixed and moving jaw with **GRIP**
jaw-plates for strongest clamping



Art.	Pag.
603	6.31
608	6.32
609	6.33

Tipo (grandezza) morsa / Vise type (size)
Art. 612

 Cubo-morsa con ganasce doppie (Art. 613)
 Vise-tower with double jaws (Art. 613)

 Ogni cubo-morsa è completo di 12 ganasce fisse,
 8 ganasce fisse mobili, 1 chiave a T, 1 coppia tasselli di
 posizionamento per cava da 16mm e 16 arresti laterali

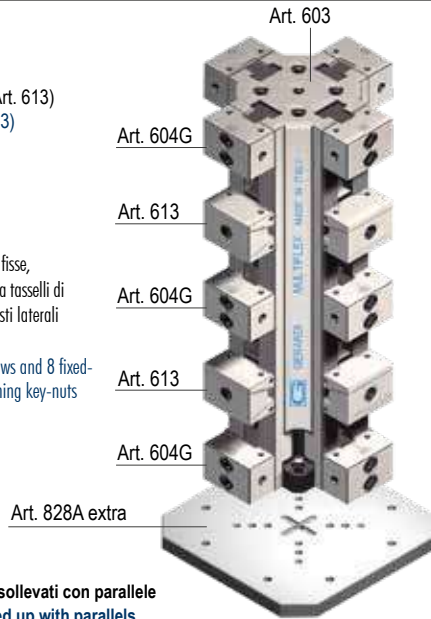
 Each vise-tower is supplied with 12 fixed jaws and 8 fixed-
 movable jaws 1 T wrench, 1 pair of positioning key-nuts
 for 16 mm slot Art. 297 and 16 workstops

kN	1				
	20 kN				
A	4 x 21mm	4 x 46	4 x 71	4 x 94	4 x 121
B	25				
C ⁻⁰ _{-0.02}	100				
D	300	400	500	600	700
G ⁻⁰ _{-0.02}	50				
J	38				
J1	44 / 50				
H	66				
Ø I ^{H7}	50				
L	20				
M	14				
W	49				
kg	24,2	29,3	34,4	39,5	44,5
Cod.	6.61.21300	6.61.21400	6.61.21500	6.61.21600	6.61.21700

 Per particolari in appoggio oppure sollevati con parallele
 For workpieces on vise base or rised up with parallels

AMPLIA LE TUE APPLICAZIONI TRAMITE GLI ACCESSORI MODULARI !
Art. 604G*

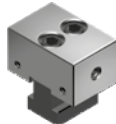
 Ganasca fissa liscia da entrambi i lati
 Fixed smooth jaws both sides

Cod. 6.60.4G100

* Arresto laterale a richiesta - Workstop on request

Art. 610B

Piastra ganasca lavorabile / Soft jaw plate



Cod. Art. 610B 6.61.0B100

Art. 610C

Piastra ganasca liscia / Smooth jaw plate



Cod. Art. 610C 6.61.0C100

Art. 610D

Piastra ganasca zigrinata / Serrated jaw plate



Cod. Art. 610D 6.61.0D100

Art. 610E

Piastra ganasca parallela / Parallel jaw plate



Cod. Art. 610E 6.61.0E100

Art. 610F

Piastra ganasca prismatica / Prismatic jaw plate



Cod. Art. 610F 6.61.0F100

Piastrine Art.610B - 610C - 610D - 610E - 610F dimensioni come pagina 6.36 - Jaw plates Art.610B - 610C - 610E - 610F dimensions as page 6.36

Art. 613

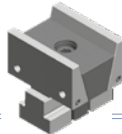
 Ganasca mobile doppia di spinta
 Double clamping movable jaws

Cod. 6.61.31000

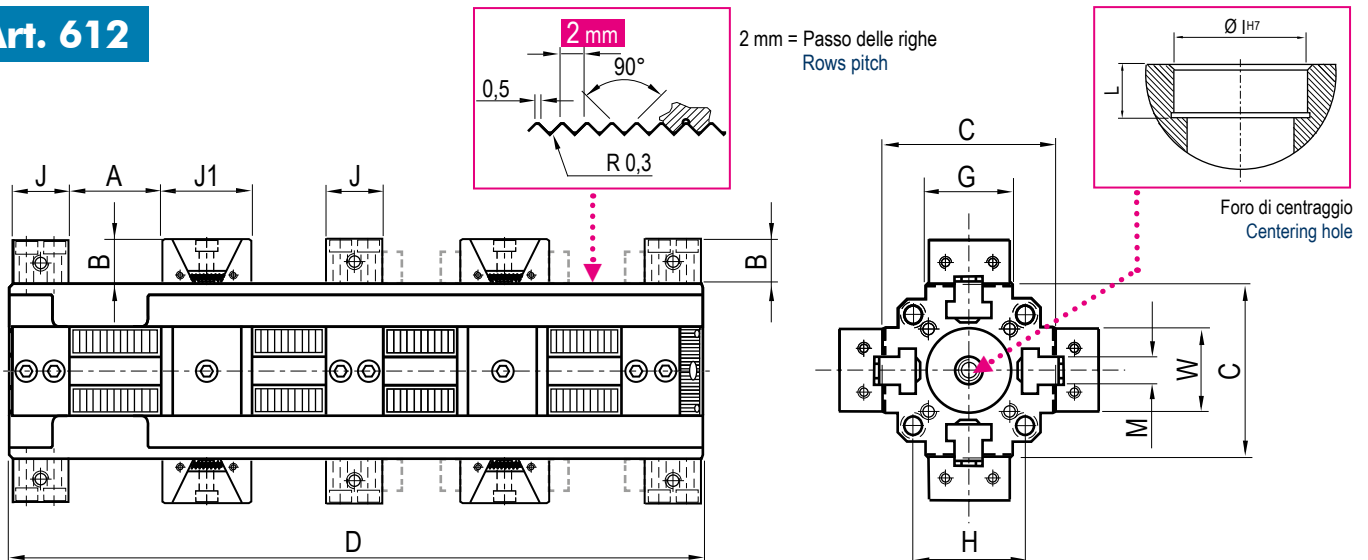
Art. 612



2 30 kN						3 40 kN						
A	4 x 34mm	4 x 59	4 x 84	4 x 84	4 x 109	4 x 109	4 x 109	4 x 134	4 x 77	4 x 102	4 x 127	4 x 152
B		40		40	40		40			60		
C ^{-0 -0.02}		150		230	150	210	240			240		
D	400	500	600	600	700	700	700	800	700	800	900	1000
G ^{-0 -0.02}		75		75	75		75			100		
J		50		50	50		50			70		
J1		52 / 58		52 / 58	52 / 58		52 / 58			84 / 90		
H		100		-	100	-	-	-		150 / 200		
Ø I ^{H7}		50		50	50		50			50		
L		20		20	20		20			20		
M		22		22	22		22			30		
W		74		74	74		74			99		
kg	72,4	83,6	94,8	137	106	142,6	170	190	244	268	291	315
Cod.	6.61.22400	6.61.22500	6.61.22600	6.61.22601	6.61.22700	6.61.22701	6.61.22702	6.61.22800	6.61.23700	6.61.23800	6.61.23900	6.61.23100

I prezzi su fondo magenta sono **comprensivi di base integrale** / Prices on the magenta background include the solid head plate with the vise-tower

UPGRADE YOUR VISE APPLICATIONS THROUGH MODULAR ACCESSORIES !

Cod.	6.60.4G200	6.60.4G300
Cod. Art. 610B	6.61.0B200	6.61.0B300
Cod. Art. 610C	6.61.0C200	6.61.0C300
Cod. Art. 610D	6.61.0D200	6.61.0D300
Cod. Art. 610E	6.61.0E200	6.61.0E300
Cod. Art. 610F	6.61.0F200	6.61.0F300

Piastrine Art.610B - 610C - 610D - 610E - 610F dimensioni come pagina 6.36 - Jaw plates Art.610B - 610C - 610E - 610F dimensions as page 6.36

Cod.	6.61.32000	6.61.33000
------	------------	------------

Art. 613

Ganascia mobile doppia di spinta
 Double clamping movable jaws

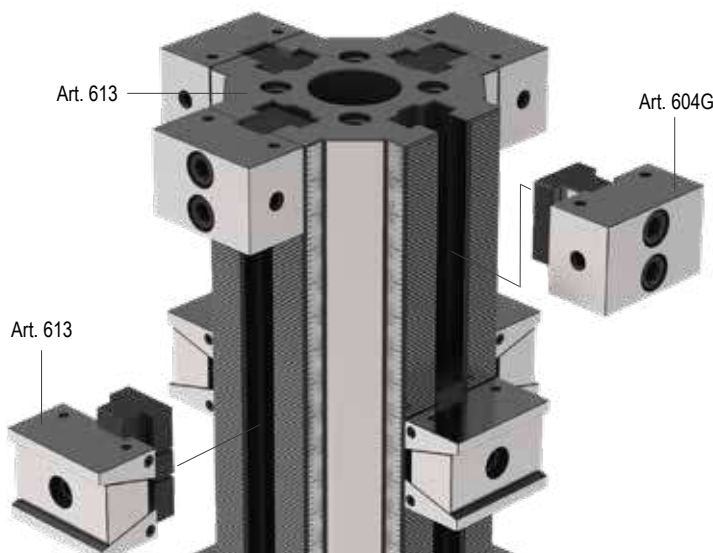

Art.	Pag.
603	6.31
604G	6.32
613	6.34

Tipo (grandezza) / Type (size)		1					2					3				
Art. 601	A	34 (M8)					50 (M10)					70 (M10)				
New 2.0 ZERO POINT READY I	A1	34 (M8)					54 (M10)					70 (M10)				
Corpo base morsa Vise base body	B	8 (M8)					12,5 (M10)					15 (M10)				
	B1	8 (M8)					10,5 (M10)					15 (M10)				
	C $\pm 0,02$	50					75					100				
	D $\pm 0,05$	300	400	500	600	700	400	500	600	700	800	900	700	800	900	1000
	E	37,5					55					75				
	F	15					20					20				
	G $\pm 0,02$	50					75					100				
	I	10					11					12				
	L $\pm 0,025$	14					22					30				
	ØP	9					13					17				
	Q $\pm 0,02$	100/200	100/200	200	300	400	200/300	200	300	400	400/500	300/400/500	400	400/500	400/500	400/500
	ØT ^{H7}	14					20					20				
	ØU	12					18					-				
	kg	4,4	5,9	7,3	8,8	10,2	13,9	17,4	20,9	24,4	27,9	31,4	42,5	48	55	60,7
	Cod.	6.60.11300	6.60.11400	6.60.11500	6.60.11600	6.60.11700	6.60.12400	6.60.12500	6.60.12600	6.60.12700	6.60.12800	6.60.12900	6.60.13700	6.60.13800	6.60.13900	6.60.13100

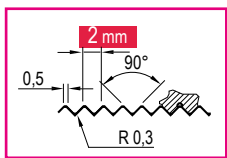

2 mm = Passo delle righe - Rows pitch

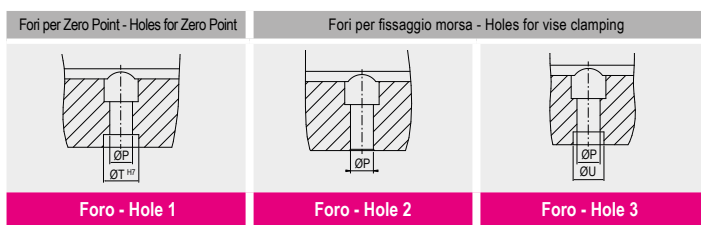
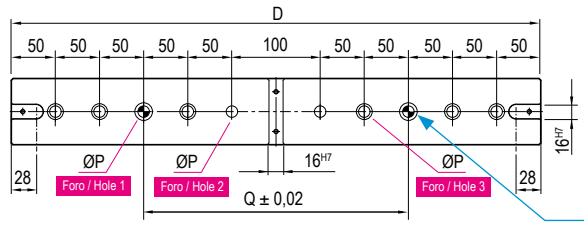

Modificabili per Zero Point
Adaptable for Zero Point

Art.96 Pag - Page 6.38
Perno di centraggio per montaggio su reticolo
Centering pin for mounting on grip plate

Tipo (grandezza) / Type (size)		1					2					3					
Art. 62	D	300	400	500	600	700	400	500	600	700	800	900	700	800	900	1000	
MULTIFLEX	G	50					75					100					
Piastra di interfaccia Zero Point per morsa MULTIFLEX Zero Point connecting plate for MULTIFLEX vises	C1	28					33					33					
	N	3	4	5	6	7	4	5	6	7	8	9	7	8	9	100	
	ZZ $\pm 0,02$	200	200	250	200x2	200	250	200x2	300x2	200x2	300x2	400x2	200x2	300x2	400x2	400x2	
	kg	3,1	4,2	5,3	6,4	7,4	7,5	9,5	11,4	13,2	15,2	17,2	17,8	20,4	23	25,5	
	Cod.	6.62.13000	6.62.14000	6.62.15000	6.62.16000	6.62.17000	6.62.24000	6.62.25000	6.62.26000	6.62.27000	6.62.28000	6.62.29000	6.62.37000	6.62.38000	6.62.39000	6.62.31000	
	A	200	200	200	200	200	200	200	200	200	200	200	200	200	200	200	
	B	400	500	600	400	500	600	800	600	800	1000						
	Art.665 Tipo / Type2																
	P	200	250	200X2	200	250	200X2	300X2	200x2	300X2	400x2						
	kg	29	35	42	29	35	42	59	42	59	71,5						
Cod.	9.81.P2040S2	9.81.P2060S2	9.81.P2060S3	9.81.P2040S2	9.81.P2060S2	9.81.P2080S3	9.81.P22080S3	9.81.P2060S3	9.81.P2080S3	9.81.P2010S3							
Art.81P Piastra Zero Point in acciaio con montaggio incassato Zero Point steel plate built-in mounting																	

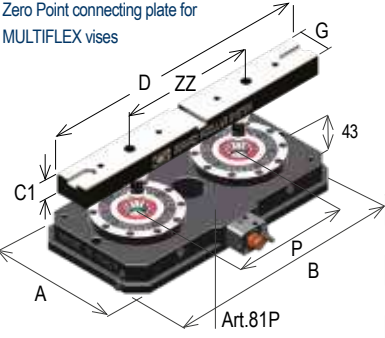

Tiranti e viti INCLUSI
Pull Studs and screws INCLUDED

Art.81P

Piastra Zero Point in acciaio
con montaggio incassato
Zero Point steel plate built-in mounting

Tipo (grandezza) / Type (size)	1					2					3									
Art. 603																				
Corpo base cubo Cube base body																				
C ^{-0,02}	100					150					230	150	210	240	240					
D	300	400	500	600	700	400	500	600	600	700	700	700	800	700	800	900	1000			
G ^{-0,02}	50					75					75	75	75				100			
Ø I ^{H7}	25					50					50	50	50				50			
L ^{-0,02}	20					20					20	20	20				20			
kg	15,4	20,5	25,6	30,7	35,8	44,8	56	67,2	110	78,4	115	143	163	164	188	211	235			
Cod.	6.60.31300	6.60.31400	6.60.31500	6.60.31600	6.60.31700	6.60.32400	6.60.32500	6.60.32600	6.60.32601	6.60.32700	6.60.32701	6.60.32702	6.60.32800	6.60.33700	6.60.33800	6.60.33900	6.60.33100			

I prezzi su fondo magenta sono **comprensivi di base integrale**
 Prices on the magenta background **include the solid head plate with the vise-tower**

Art. 603

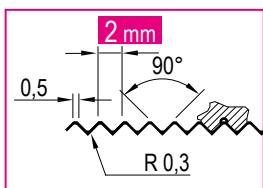
 Corpo cubo semplice
 Simple cube body

2 mm =
 Passo delle righe
 Rows pitch

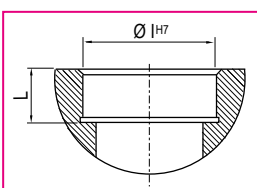

Foro di centraggio
 Centering hole

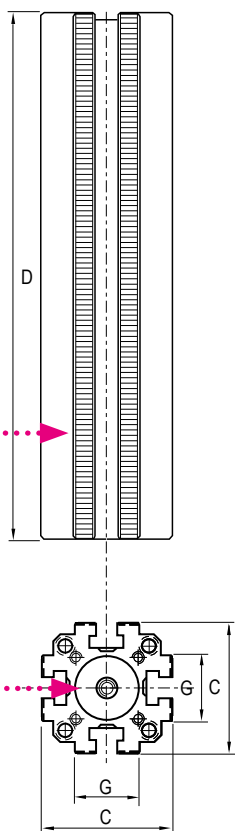
Art. 603

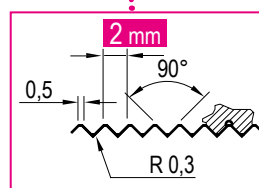
 Corpo cubo con base integrale
 Cube body with integral base

2 mm = Passo delle righe
 Rows pitch

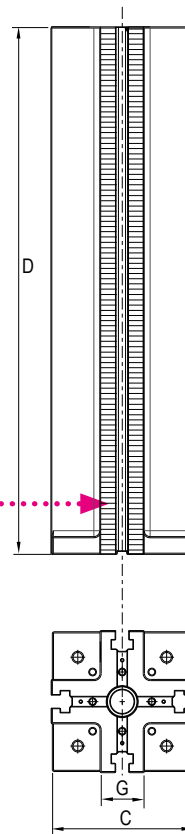
Art. 828A
MULTIFLEX

 Piastra base per
 cubo-morsa
 personalizzata
 (Bussola di centraggio
 Art. 852 compresa)

 Head plate for vise-tower
 tailor made

(Centering bushing Art. 852 included)

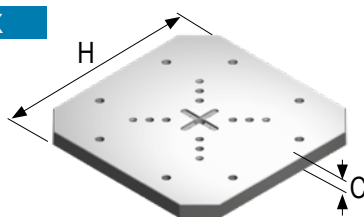

	1	2	3	4	5	6	7
C	33	33	38	38	38	38	38
H	300	350	400	450	500	630	800
kg	22	30	44,5	56,5	71	113	182
Cod.	6.82.8A100	6.82.8A200	6.82.8A300	6.82.8A400	6.82.8A500	6.82.8A600	6.82.8A700

Tipo (grandezza) / Type (size)	1	2	3
--------------------------------	---	---	---

Art. 604*

 Ganaschia fissa (1 lato liscia, 1 lato zigrinata) per morsa Art. 600 e 602
 Fixed jaw (1 side smooth, 1 side serrated) for vise Art. 600 and 602

kg	0,4	1,35	3,84
Cod.	6.60.41000	6.60.42000	6.60.43000

* Arresto laterale a richiesta - Workstop on request

Art. 604G*

 Ganaschia fissa liscia da entrambi i lati, per morsa Art. 611 e cubi Art. 612
 Fixed smooth jaw both sides, for vise Art. 611 and cubes Art. 612

kg	0,5	1,40	3,90
Cod.	6.60.4G100	6.60.4G200	6.60.4G300

* Arresto laterale a richiesta - Workstop on request

Art. 604T*

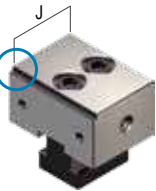
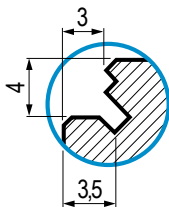
 Ganaschia fissa GRIP per morsa Art. 606T
 Fixed GRIP jaw for vise Art. 606T

J	38	50	70
Cod.	6.60.4T100	6.60.4T200	6.60.4T300

* Arresto laterale a richiesta - Workstop on request

Art. 608*

 Ganaschia fissa con gradino per morsa Art. 606
 Fixed step jaw for vise Art. 606

J	38	50	70
kg	0,45	1,4	4
Cod.	6.60.81000	6.60.82000	6.60.83000

* Arresto laterale a richiesta - Workstop on request

Art. 614T*

 Ganaschia fissa con doppio gradino
 Fixed jaw with double step

Cod.	6.61.4T100	6.61.4T200	6.61.4T300
------	------------	------------	------------

* Arresto laterale a richiesta - Workstop on request

6

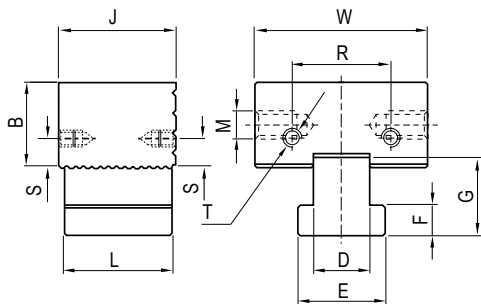
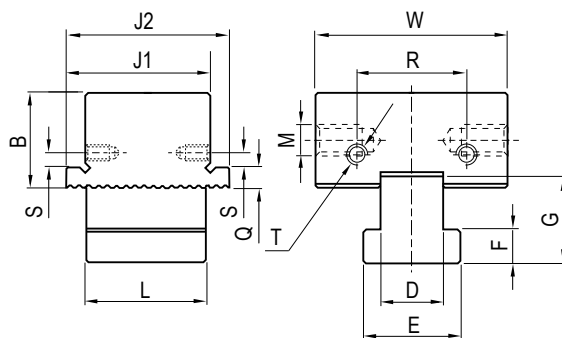
Art. 604

Art. 608
Art. 614T

Art.	1	2	3
W	49	74	99
B	25	40	60
D	14	22	30
E	22	35	48
F	8	14	21
G	21	33	46
J	38	50	70
J1	43	55	75
J2	48	60	80
L	30	45	60
M	M10	M10	M10
Q	5	8	10
R	30	50	50
S	7	10	10
T	M5	M6	M6

Tipo (grandezza) / Type (size)
Art. 605*

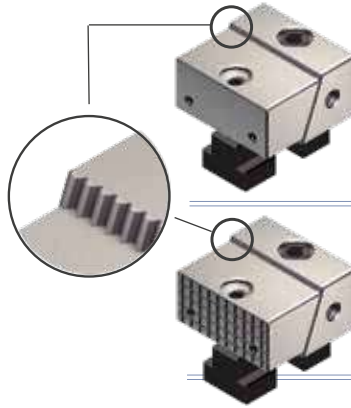
 Ganascia fissa e mobile liscia per morsa Art. 600
 Fixed and movable smooth jaw for vise Art. 600

 Ganascia discendente guidata / Sistema a pettine (Particolare)
 Guided pull down jaw / Comb system (Detail)

kg	0.6	1.8	4.7
Cod.	6.60.51000	6.60.52000	6.60.53000

* Arresto laterale a richiesta - Workstop on request

Art. 605S*

 Ganascia fissa e mobile zigrinata per morsa Art. 600
 Fixed and movable serrated jaw Art. 600

Art. 605W*

 Ganascia fissa zigrinata e mobile liscia per morsa Art. 600
 Serrated fixed jaw and movable smooth for vise Art. 600

kg	0.6	1.8	4.7
Cod.	6.60.5S100	6.60.5S200	6.60.5S300

* Arresto laterale a richiesta - Workstop on request

Cod.	6.60.5W100	6.60.5W200	6.60.5W300
------	------------	------------	------------

* Arresto laterale a richiesta - Workstop on request

Art. 609*

 Ganascia fissa e mobile con gradino per morsa Art. 606
 Fixed and moving jaw with step for vise Art. 606

kg	0.8	2.2	5.5
Cod.	6.60.91000	6.60.92000	6.60.93000

* Arresto laterale a richiesta - Workstop on request

Art. 609T*

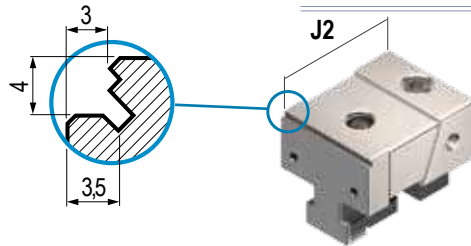
 Ganascia fissa e mobile GRIP per morsa Art. 606T
 Fixed and moving GRIP jaw for vise Art. 606T

Cod.	6.60.9T100	6.60.9T200	6.60.9T300
------	------------	------------	------------

* Arresto laterale a richiesta - Workstop on request

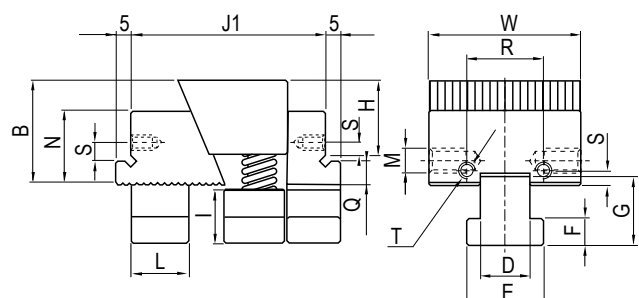
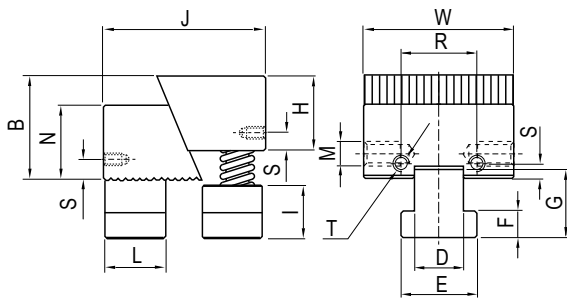
Art. 605
Art. 605S
Art. 605W
Art. 609
Art. 609T

Art.	1	2	3
W	49	74	99
B	35 / 25	40	60
D	14	22	30
E	22	35	48
F	8	14	21
G	25	33	46
H	25	34	50
I	18	26	42
J	54 / 58	70 / 75	94,5 / 98,5
J1	63,5 / 67,5	85 / 88	114,5 / 119
J2	70 / 74	87 / 90	120,5 / 115,5
L	22	26	35
M	M10	M10	M10
N	25	40	60
Q	5	8	10
R	30	50	50
S	7	10	10
T	M5	M6	M6

Tipo (grandezza) / Type (size)	1	2	3
--------------------------------	---	---	---

Art. 613

 Ganaschia mobile di spinta doppia per morza Art. 611
 Double clamping movable jaws for vise Art. 611

kg	0.5	1.4	4.3
Cod.	6.61.31000	6.61.32000	6.61.33000

Art. 615*

 Ganaschia di posizionamento liscia maggiorata
 e cuneo mobile liscio
 Bigger positioning smooth jaw with movable smooth wedge
 (Increased with respect to standard dimensions)

Cod.Art.615	6.61.51000	6.61.52000	6.61.53000
Cod.Art.615S	6.61.5S100	6.61.5S200	6.61.5S300
Cod.Art.615W	6.61.5W100	6.61.5W200	6.61.5W300

Art. 615S

 Ganaschia di posizionamento zigrinata maggiorata
 e cuneo mobile zigrinato
 Bigger positioning serrated jaw with movable serrated wedge
 (Increased with respect to standard dimensions)

Art. 615W*

 Ganaschia di posizionamento zigrinata maggiorata
 e cuneo mobile liscio
 Bigger positioning serrated jaw with movable smooth wedge
 (Increased with respect to standard dimensions)

* Arresto laterale a richiesta Workstop on request

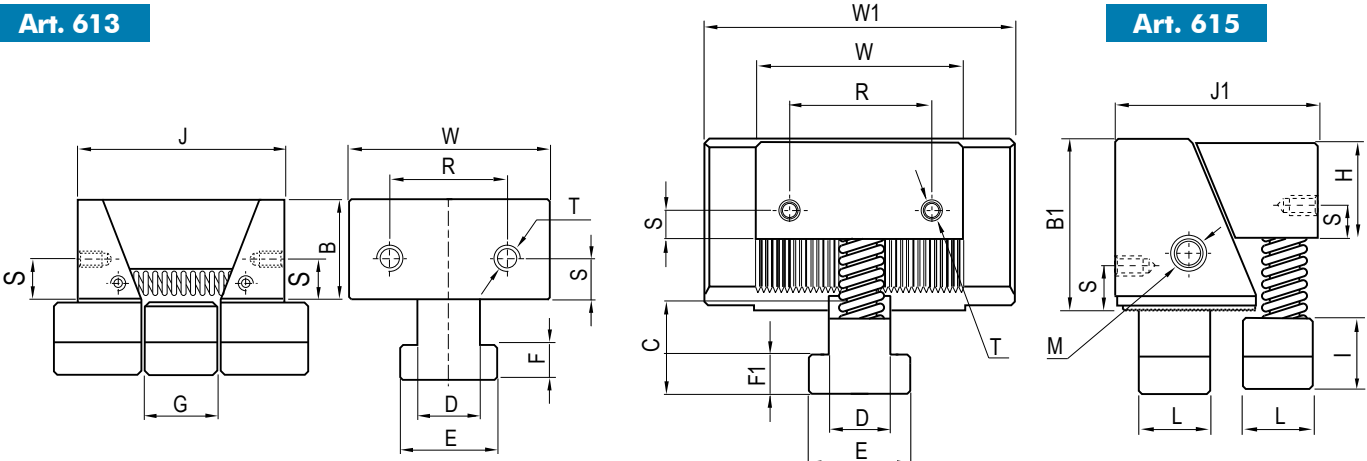
Art. 613
Art. 615

Art.	1	2	3
W	49	74	99
W1	64	110	150
B	25	40	60
B1	45	60	75
C	21	33	46
D	14	22	30
E	22	35	48
F	9	15	21
F1	8	14	21
G	13	15	25
H	25	34	50
I	18	26	40
J	44 / 50	52 / 58	84 / 90
J1	54 / 58	73 / 79	94.5 / 98.5
L	22	25	35
M	M10	M10	M10
N	45	60	75
R	30	50	50
S	7	10	10
T	M5	M6	M6

6

Tipo (grandezza) / Type (size)		1	2	3
Art. 604 Ganascia fissa (1 lato liscia, 1 lato zigrinata) / Fixed jaw (1 side smooth, 1 side serrated)		Cod. 6.60.41000	6.60.42000	6.60.43000
Art. 604A Ganascia fissa (un lato liscio e uno zigrinato) / Fixed jaw (1 side smooth, 1 side serrated)		Cod. 6.60.4A100	6.60.4A200	6.60.4A300
Art. 604B Dado a "T" per ganascia fissa / "T" nut for fixed jaw		Cod. 6.60.4B100	6.60.4B200	6.60.4B300
Art. 604C Vite TCEI fissaggio ganascia fissa / Hex socket head screw for fixed jaw		Cod. 6.60.4C100	6.60.4C200	6.60.4C300
Art. 605A Cuneo di posizionamento / Positioning wedge		Cod. 6.60.5A100	6.60.5A200	6.60.5A300
Art. 605AS Cuneo di posizionamento zigrinato / Serrated positioning wedge		Cod. 6.60.5AS10	6.60.5AS20	6.60.5AS30
Art. 605B Cuneo di spinta / Clamping wedge		Cod. 6.60.5B100	6.60.5B200	6.60.5B300
Art. 605BS Cuneo di spinta zigrinato / Serrated clamping wedge		Cod. 6.60.5BS10	6.60.5BS20	6.60.5BS30
Art. 605C Dado a "T" per cuneo di posizionamento / "T" nut for positioning wedge		Cod. 6.60.5C100	6.60.5C200	6.60.5C300
Art. 605D Dado a "T" per cuneo di spinta / "T" nut for clamping wedge		Cod. 6.60.5D100	6.60.5D200	6.60.5D300
Art. 605E Vite TCEI / TCEI screw		Cod. 6.60.5E100	6.60.5E200	6.60.5E300
Art. 605F Anello elastico / Seeger		Cod. 6.60.5F100	6.60.5F200	6.60.5F300
Art. 605G1 Vite a gradino / Step screw		Cod. 6.60.5G101		6.60.5G103
Art. 605G2 Perno a molla / Spring pin		Cod. 6.60.5G201	6.60.5G202	6.60.5G203
Art. 605G3 Molla / Spring		Cod. 6.60.5G301		6.60.5G303
Art. 605H Molla / Spring		Cod. 6.60.5H100	6.60.5H200	6.60.5H300
Art. 605I Cuneo a spinta dolce / Soft clamping wedge		Cod. 6.60.5I100	6.60.5I200	6.60.5I300
Art. 605L Cuneo di spinta a "V" / "V" clamping wedge		Cod. 6.60.5L100	6.60.5L200	6.60.5L300
Art. 605M Rondella / Washer		Cod. 6.60.5M100	6.60.5M200	6.60.5M300

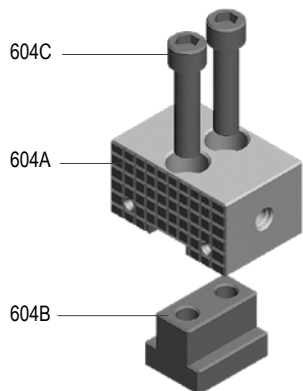

Art. 604

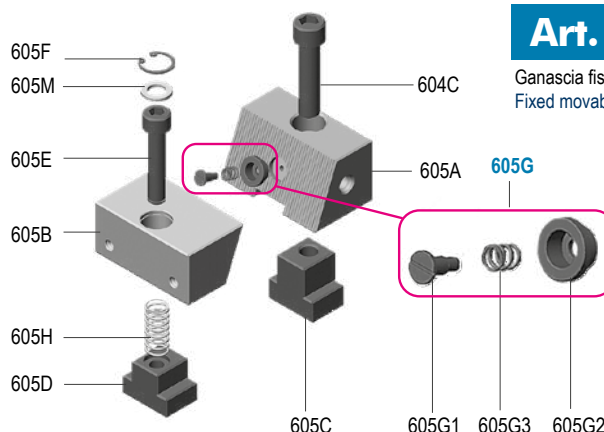
Ganascia fissa
(1 lato liscia, 1 lato zigrinata)
per morsa **Art. 600 e 602**
Fixed jaw
(1 side smooth, 1 side serrated)
for vise **Art. 600 and 602**

Art. 605

Ganascia fissa mobile
Fixed movable jaw

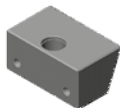
Tipo (grandezza) / Type (size)
1 2 3
Art. 605B

 Cuneo di spinta
Clamping wedge

Art. 605BT

 Cuneo di spinta per piastra GRIP
Clamping wedge for GRIP plate

Cod. Art. 605B	6.60.5B100	6.60.5B200	6.60.5B300
Cod. Art. 605BT	6.60.5BT10	6.60.5BT20	6.60.5BT30

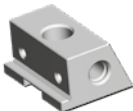
Art. 609A

 Cuneo di posizionamento con gradino
Positioning wedge with step

Art. 609AT

 Cuneo di posizionamento GRIP
Positioning GRIP wedge

Cod. Art. 609A	6.60.9A100	6.60.9A200	6.60.9A300
Cod. Art. 609AT	6.60.9AT10	6.60.9AT20	6.60.9AT30

Art. 609B

 Ganascia mobile guidata con gradino
Movable guided jaw with step

Art. 609BT

 Ganascia mobile guidata GRIP
Movable guided GRIP jaw

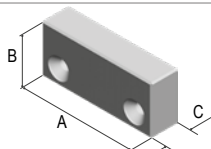

Cod. Art. 609B	6.60.9B100	6.60.9B200	6.60.9B300
Cod. Art. 609BT	6.60.9BT10	6.60.9BT20	6.60.9BT30

Art. 610B

 Piastra ganascia dolce
Soft jaw plate

A	48	73	98
B	20	32	50
C	12	18	30
Cod.	6.61.0B100	6.61.0B200	6.61.0B300

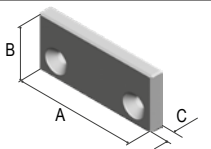
Art. 610C

 Piastra ganascia liscia
Smooth jaw plate

A	48	73	98
B	20	32	50
C	6	10	10
Cod.	6.61.0C100	6.61.0C200	6.61.0C300

Art. 610D

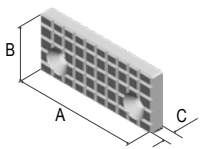
 Piastra ganascia zigrinata
Serrated jaw plate

A	48	73	98
B	20	32	50
C	6	10	10
Cod.	6.61.0D100	6.61.0D200	6.61.0D300

Art. 610E

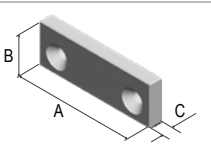
 Piastra ganascia parallela
Parallel jaw plate

A	48	73	98
B	15	27	45
C	6	10	10
Cod.	6.61.0E100	6.61.0E200	6.61.0E300

Art. 610T

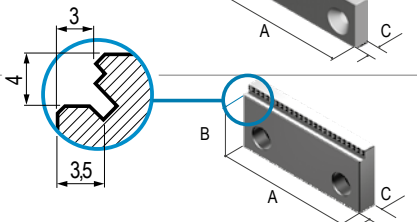
 Piastra ganascia GRIP a forte serraggio
GRIP jaw plate for strongest clamping

A	48	73	98
B	20	32	50
C	8	10	10
Cod.	6.61.0T100	6.61.0T200	6.61.0T300

Art. 610F

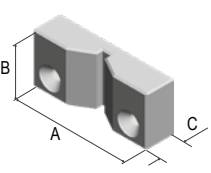
 Piastra ganascia prismatica
Prismatic jaw plate

Ø	5 ÷ 35	9 ÷ 50	20 ÷ 80
A	48	73	98
B	20	32	50
C	12	18	30
Cod.	6.61.0F100	6.61.0F200	6.61.0F300

Art. 610Z

 Vite per piastre ganasce
Screw for jaw plates

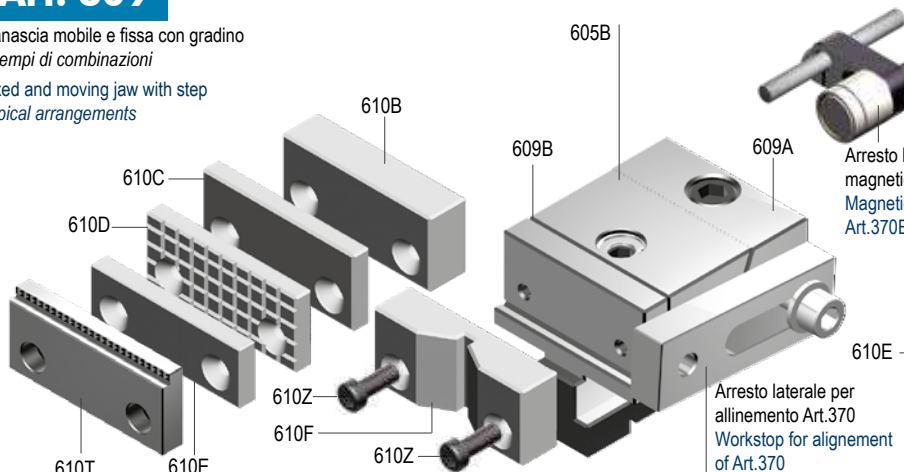

Cod.	6.61.0Z100	6.61.0Z200	6.61.0Z300
------	------------	------------	------------

Art. 609

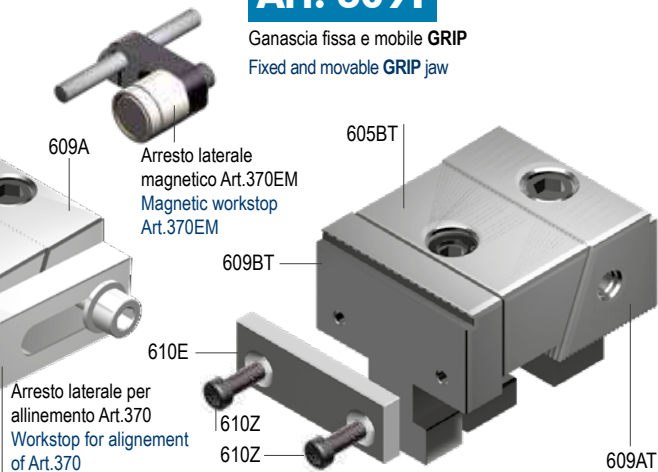
 Ganascia mobile e fissa con gradino
Esempi di combinazioni
Fixed and moving jaw with step
Typical arrangements

Art. 609T

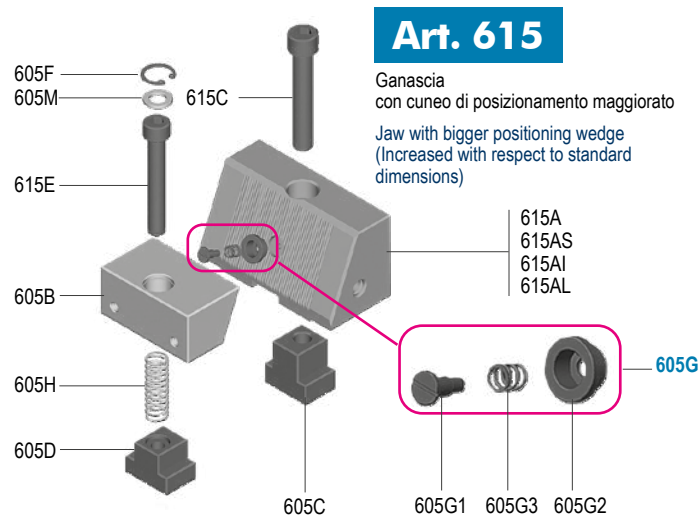
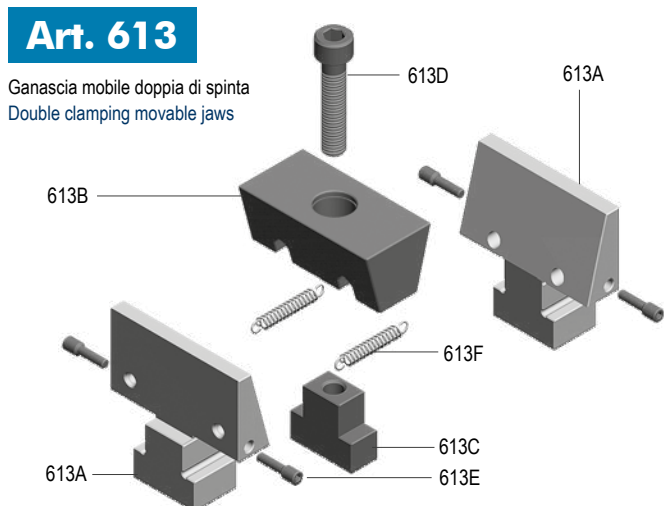
 Ganascia fissa e mobile GRIP
Fixed and movable GRIP jaw

Tipo (grandezza) / Type (size)	1	2	3	
Art. 608A Ganascia fissa con gradino Fixed jaw with step		Cod. 6.60.8A100	6.60.8A200	6.60.8A300
Art. 613A Ganascia mobile Movable jaw		Cod. 6.61.3A100	6.61.3A200	6.61.3A300
Art. 613B Cuneo di spinta Clamping wedge		Cod. 6.61.3B100	6.61.3B200	6.61.3B300
Art. 613C Dado a "T" "T" nut		Cod. 6.61.3C100	6.61.3C200	6.61.3C300
Art. 613D Vite TCEI Hex socket head screw		Cod. 6.61.3D100	6.61.3D200	6.61.3D300
Art. 613E Grano Set screw		Cod. 6.61.3E100	6.61.3E200	6.61.3E300
Art. 613F Molla Spring		Cod. 6.61.3F100	6.61.3F200	6.61.3F300
Art. 615A Cuneo di posizionamento liscio maggiorato Positioning wedge smooth (increased with respect to stand dimension)		Cod. 6.61.5A100	6.61.5A200	6.61.5A300
Art. 615AS Cuneo di posizionamento zigrinato maggiorato Positioning wedge serrated (increased with respect to stand dimension)		Cod. 6.61.5AS10	6.61.5AS20	6.61.5AS30
Art. 615I Cuneo di posizionamento dolce maggiorato Positioning wedge soft (increased with respect to stand dimension)		Cod. 6.61.5I100	6.61.5I200	6.61.5I300
Art. 615L Cuneo di posizionamento a gradino maggiorato Positioning wedge with stop (increased with respect to stand dimension)		Cod. 6.61.5L100	6.61.5L200	6.61.5L300
Art. 615C Vite TCEI fissaggio ganascia fissa Hex socketed head screw for fixed jaw		Cod. 6.61.5C100	6.61.5C200	6.61.5C300
Art. 615E Vite TCEI TCEI screw		Cod. 6.61.5E100	6.61.5E200	6.61.5E300



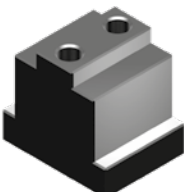
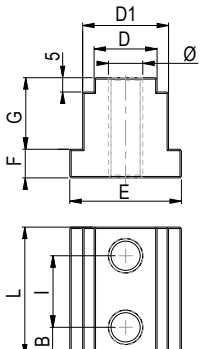

DADI A "T" PER TRASFORMAZIONI

"T" NUTS FOR TRANSFORMATIONS

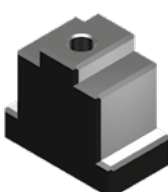
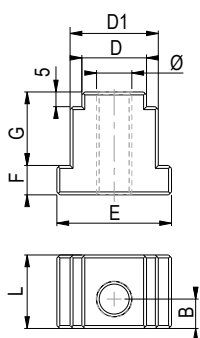
Tipo (grandezza) / Type (size)	Base / Base Ganascia / Jaw	Tipo - Type 2 Tipo - Type 1	Tipo - Type 3 Tipo - Type 1	Tipo - Type 3 Tipo - Type 2	
Art. 604B Dado a "T" per ganascia fissa "T" nut for fixed jaw 		B	6	6	10
		D	14	14	22
		D1	22	30	30
		E	34	39	39
		F	14	14	14
		G	19	25	25
		I	18	18	25
		L	30	30	45
		Ø	M8	M8	M12
		Cod	6.60.4B100/2	6.60.4B100/3	6.60.4B200/3
€	14	15	18		

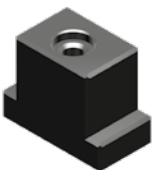
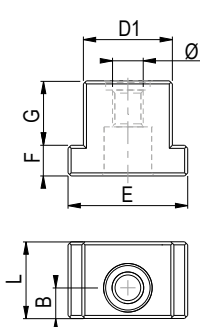
Art. 605C Dado a "T" per cuneo di posizionamento "T" nut for positioning wedge 		B	9	9	10
		D	14	14	22
		D1	22	30	30
		E	34	39	39
		F	14	14	14
		G	19	25	25
		I	-	-	-
		L	22	22	25
		Ø	M8	M8	M12
		Cod	6.60.5C100/2	6.60.5C100/3	6.60.5C200/3
€	12	12	18		

Art. 605D Dado a "T" per cuneo di spinta "T" nut for clamping wedge 		B	9	9	10
		D	-	-	-
		D1	21	29	29
		E	34	39	39
		F	14	14	14
		G	15	21	21
		I	-	-	-
		L	21	21	25
		Ø	M8	M8	M10
		Cod	6.60.5D100/2	6.60.5D100/3	6.60.5D200/3
€	12	13	15		

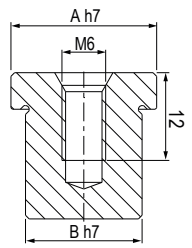
Tipo (grandezza) / Type (size)	1	2	3	
Multiflex 2.0 ZERO POINT READY I Art. 96 Perno di centraggio per montaggio morse Multiflex 2.0 su reticolo Centering pin for mounting Multiflex 2.0 viseson grip plate 				
	ØA	14		20
	ØB	10	16	16
	Cod	C96141015-601	C96141615-601	C96141615-601
	€	26	26	26

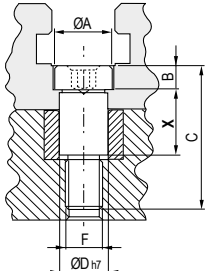
Art. 81 Vite calibrata a colletto per morse Multiflex (Non versione 2.0) Shoulder calibrated screw for Multiflex vises (Not for 2.0 issue) 	ØA	13	20	24
	B	8	8	12
	C	46	65	80
	ØD	10	16	16
	F	M8	M12	M12
	X	25	40	50
	Cod	6.81.11025	8.83.B1640	8.83.16500
	€	12	13	14

N.B.: Per avere altre lunghezze consultare Pag.11.15 - For other lengths see Page.11.15

LUNGHEZZA VITI CALIBRATE A COLLETTA PER SOLUZIONI A RETICOLO
SHOULDER CALIBRATED SCREW LENGTHS FOR GRID SOLUTIONS

Tipo (grandezza) / Type (size)		1	2	3	
Art. 616	Coppia di piastre parallele magnetiche piane Pair of straight parallels magnetic plates				
		J 2,7 W 49 H 20 Cod. 6.61.6100C	2,7 74 35 6.61.6200C	2,7 99 55 6.61.6300C	
Art. 617	Piastra magnetica a gradino monoblocco Magnetic solid step jaw plate				
		J 12 W 49 H 20 Cod. 6.61.71020	17 74 35 6.61.72035	22 99 55 6.61.73055	
Art. 618	Ganascia fissa ridotta Narrow width fixed jaw				
		618 618 618 613 613 J 18 W 49 H 25 Cod. 6.61.81000	22 74 40 6.61.82000	29 99 60 6.61.83000	
Art. 604R	Ganascia fissa di partenza Fixed start jaw				
		PER UNA MAGGIORE APERTURA - FOR MORE OPENING CAPACITY			
		W 49 J 25 B 25 Cod. 6.60.4R100	74 30 40 6.60.4R200	99 35 60 6.60.4R300	
Art. 608R	Ganascia fissa di partenza con gradino Fixed start jaw with step				
		PER UNA MAGGIORE APERTURA - FOR MORE OPENING CAPACITY			
		W 49 J 26 B 25 Cod. 6.60.8R100	74 36 40 6.60.8R200	99 41 60 6.60.8R300	
Art. 604PC	Piastra ganascia fissa di partenza per cubo-morsa Fixed start jaw plate for vise tower				
		*Scegliere la dimensione A in funzione del cubo utilizzato, vedi Art.603 a pag. 6.31 Referring to the cube you are using, choose dimension "A", see Art.603 page. 6.31			
		A 150 W 49 J 20 B 25 Cod. 6.60.4PC10	230 74 25 40 6.60.4PC20	290 99 30 60 6.60.4PC30	
Art. 79 R	Tassello di allineamento regolabile per Multiflex montata su cubo portapezzi Adjustable alignment pin for Multiflex vise mounted on tombstone				
		Cod. 6.79.R1000 € 20			
Art. 297 R	Tassello di allineamento per Multiflex montata su cubo portapezzi Alignment key-nut for Multiflex vise mounted on tombstone				
		Cod. 6.29.7R100 € 16			
Art. 370EM	Arresto laterale magnetico Magnetic workstop				
		Cod. 7.37.02000/EM € 66			
Art. 376	Chiave a T T wrench				
		CH 6 Cod. 0.09.23600 € 15	8 0.09.24800 € 16	10 0.09.25100 € 18	14 0.09.27140 € 20

SERRAGGIO A CUNEO DISCENDENTE

JAWS WEDGE CLAMP

Tipo (grandezza) / Type (size)		1	2	3
	kN	15	30	60
Art.723A				
Ganascia liscia con fori filettati Smooth jaw with holes				
	W	31	42	58
	C	16	23	30
	ØD	M8	M12	M16
	E	2	3,5	4
	G	7,5	11,5	15
	H	12	18	26
	J	27 ÷ 32	42 ÷ 49	57 ÷ 66
	L	20	30	35
	ØT	M5	M5	M5
	Cod.	6.72.3A100	6.72.3A200	6.72.3A300

Acciaio Temprato - Hardened Steel

Tipo (grandezza) / Type (size)		1	2	3
	kN	15	30	60
Art.723B				
Ganascia zigrinata Serrated jaw				
	W	31	42	58
	C	16	23	30
	ØD	M8	M12	M16
	E	2	3,5	4
	J	27 ÷ 32	42 ÷ 49	57 ÷ 66
	L	20	30	35
	ØT			
	Cod.	6.72.3B100	6.72.3B200	6.72.3B300

Acciaio Temprato - Hardened Steel

Tipo (grandezza) / Type (size)		1	2	3
	kN	15	30	60
Art.723C				
Ganascia lavorabile Machineable jaw				
	W	31	42	58
	C	16	23	30
	ØD	Ø56	Ø56	Ø76
	E	2	3,5	4
	J	33 ÷ 38	52 ÷ 59	67 ÷ 76
	L	20	30	35
	ØT			
	Cod.	6.72.3C100	6.72.3C200	6.72.3C300

NON Temprato - NOT Hardened

Grazie alla vite di serraggio viene premuto il cuneo verso il basso generando una forza di serraggio laterale
 Tightening of clamping screw presses the wedge to generate clamping force sideways

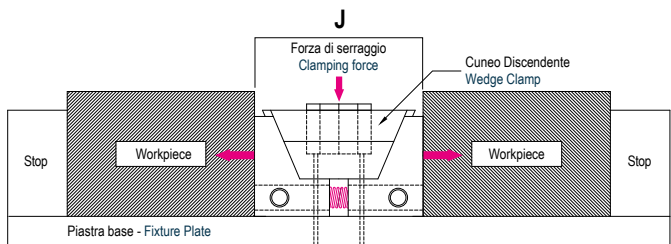

	J								
	min.	Valore consigliato Suggested value	max.	min.	Valore consigliato Suggested value	max.	min.	Valore consigliato Suggested value	max.
Art. 723 A/B	27	29÷30	32	42	45÷46	49	57	61÷63	66
Art. 723 C	33	35÷36	38	52	55÷56	59	67	71÷73	76

Il nuovo design migliorato e brevettato con molla inferiore assicura una maggiore forza di serraggio verso il basso.
 Improved patented design with bottom spring ensures downward clamping force

SERRAGGIO A CUNEO DISCENDENTE

JAWS WEDGE CLAMP

Se il tuo pezzo è adatto per il serraggio con i moduli di serraggio a cuneo discendente Gerardi, il nostro team è in grado di progettare e produrre un'attrezzatura di serraggio multipla come quello mostrato in figura. Mandateci le vostre richieste con le specifiche del pezzo o della tavola macchina del vostro centro di lavoro per consentirci di verificare l'idoneità dei nostri moduli di serraggio a cuneo discendente e presentare un'offerta adatta a voi.

If your workpiece is suitable for clamping with Gerardi wedge clamps, our team can design and manufacture a multiple clamping fixture for you as the one shown in the picture. Please send us your enquiries with workpiece + machine table specifications of your machining center to enable us check suitability of our wedge clamps and submit an offer to you

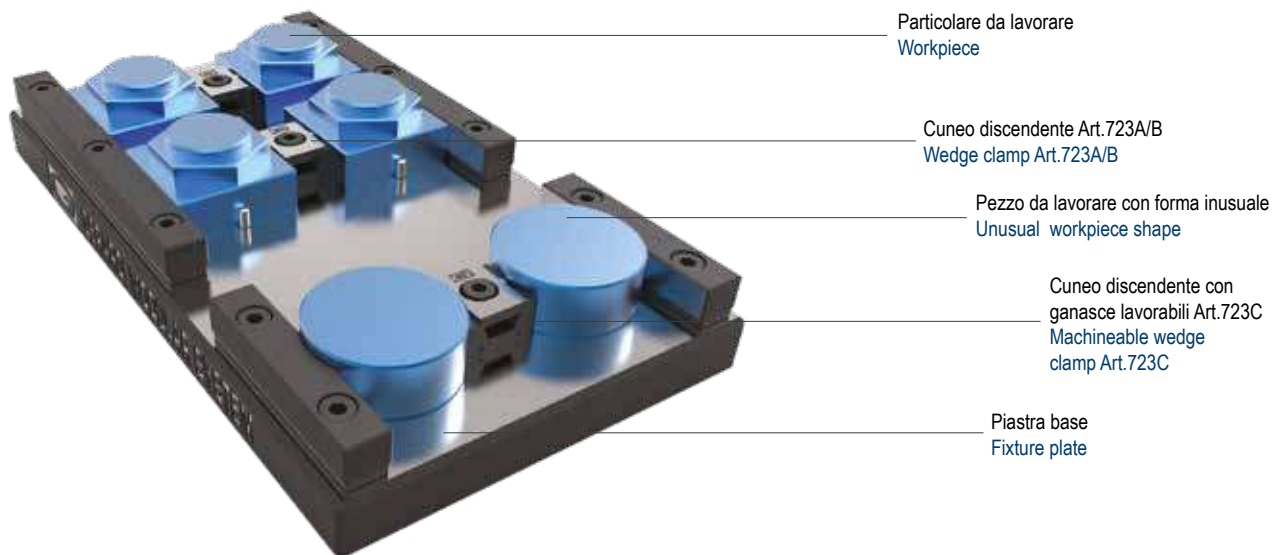

PARTI DI RICAMBIO e ACCESSORI

SPARE PARTS and ACCESSORIES

- | | | | |
|----------|---|----------|--|
| 1 | VITA TESTA ESAGONALE
HEXAGONAL HEAD SCREW | 5 | MOLLE
SPRINGS |
| 2 | CUNEO DI SPINTA
WEDGE CLAMP | 6 | ARRESTI LATERALI
WORKSTOPS |
| 3 | GANASCE MOBILI
MOVABLE JAW | 7 | PIASTRA BASE
BASE PLATE |
| 4 | GRANI
GRAIN | 8 | PEZZI DA LAVORARE
WORKPIECES |

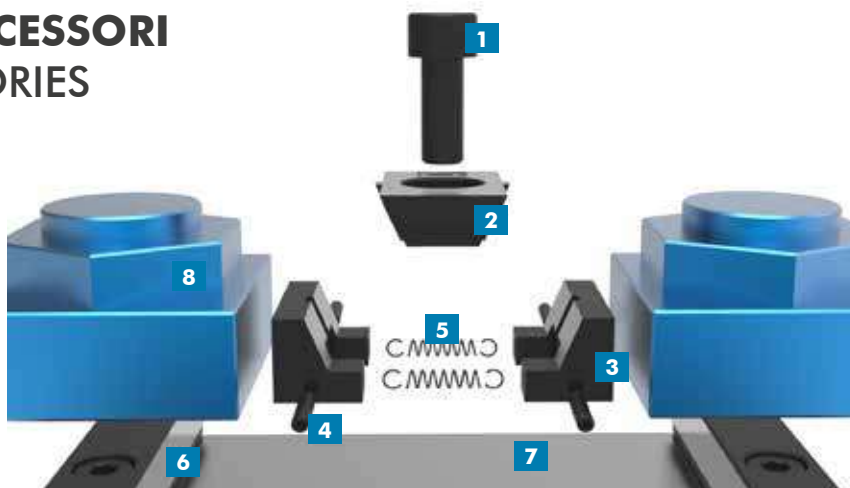

ESEMPI APPLICATIVI

BESPOKEN APPLICATION'S EXAMPLES



Sovratavola con sistema di serraggio a cunei discendenti per un serraggio di due pezzi contemporaneamente con un solo cuneo. Il tutto è montato su piastra ZeroPoint.
 Head plate interfaced for clamping system with descending wedges. For clamping of two pieces simultaneously with only one wedge. All the fixture is mounted on a Zero Point plate.



Sovratavola ZeroPoint con sistema di serraggio a cunei discendenti su file multiple. Questo consente un serraggio di due pezzi contemporaneamente con un solo cuneo. Il tutto è montato su piastra ZeroPoint.
 Head plate interfaced for clamping system with descending wedges on multiple rows. For clamping of two pieces simultaneously with only one wedge. All the fixture is mounted on a Zero Point plate.

Dimensioni - Dimensions
Art. 57F

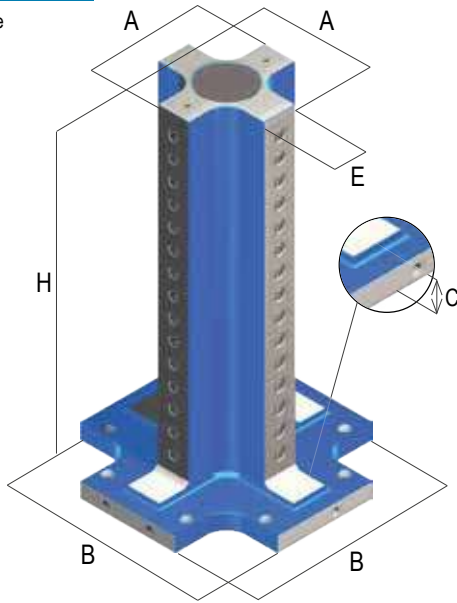
 Cubo a croce
 Cross tower

A	B	C	E	H	kg	Art. 57F 40		Art. 57F 50	
						Cod.		Cod.	
200	500	40	80	750	154	8.57.F40100		8.57.F00100	
200	500	40	80	650	140	8.57.F40105		8.57.F00105	
250	500	40	80	750	194	8.57.F40106		8.57.F00106	
270	500	40	80	850	232	8.57.F40110		8.57.F00110	
230	500	40	110	850	214	8.57.F40120		8.57.F00120	
300	500	40	150	850	264	8.57.F40130		8.57.F00130	
300	630	40	150	950	322	8.57.F40140		8.57.F00140	
370	500	40	200	950	379	8.57.F40145		8.57.F00145	
400	500	50	100	850	228	8.57.F.40150		8.57.F00150	
1000	1250	40	600	900	1554	8.57.F40250		8.57.F00250	

Art. 57F 40

 Croce a reticolo con bussole temprate 100Cr6 e filetti riportati in acciaio inox. Tolleranza $\pm 0,02$ mm
 ■ Interasse reticolo 40 mm = $\varnothing 12 / M10$
 ■ Interasse reticolo 50 mm = $\varnothing 16 / M12$
Art. 57F 50

 Crosscube grid type with hardened bushing 100Cr6 and inox steel helicoils. Tolerance $\pm 0,02$ mm
 ■ Grid pitch 40 mm = $\varnothing 12 / M10$
 ■ Grid pitch 50 mm = $\varnothing 16 / M12$
Dimensioni - Dimensions
Art. 57G

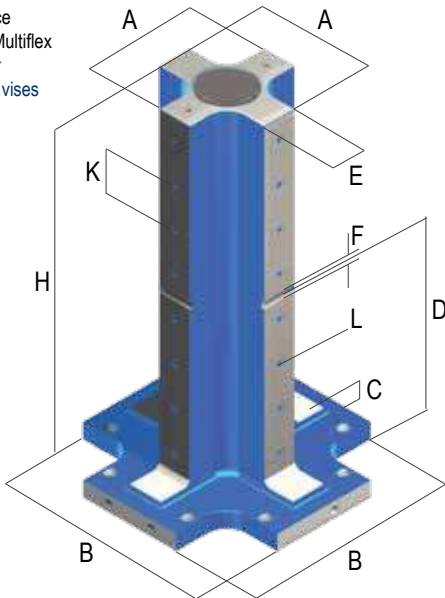
 Cubo a croce per morse Multiflex
 Cross tower for Multiflex vises

A	B	C	D	E	F	H	K	L	kg	Cod.
200	500	40	350	80	16	750	50	M12	154	8.57.G00100
200	500	40	350	80	16	650	50	M12	140	8.57.G00105
250	500	40	400	80	16	750	50	M12	194	8.57.G00106
270	500	40	450	80	16	850	50	M12	232	8.57.G00110
230	500	40	450	110	16	850	50	M12	214	8.57.G00120
300	500	40	450	150	16	850	50	M12	264	8.57.G00130
300	630	40	500	150	16	950	50	M12	322	8.57.G00140
370	500	40	500	200	16	950	50	M12	379	8.57.G00145
400	500	50	450	100	16	850	50	M12	228	8.57.G00150

Art. 79R

 Perno di allineamento regolabile per Multiflex montata su cubo portapezzi
 Adjustable alignment pin for Multiflex vise mounted tombstone

Cod. 6.79.R1000

Art. 297R

 Tassello di allineamento per Multiflex montata su cubo portapezzi
 Alignment key-nut for Multiflex vise mounted on tombstone

Cod. 6.29.7R100

Diagrammi di serraggio / Clamping diagrams

MULTIFLEX

Diagrammi di serraggio meccanico con chiave dinamometrica

Mechanical clamping diagrams with torque wrench

Art. 357

Morse tipo Vises type

1

Cuneo di spinta:
Momento massimo applicato 40Nm
Clamping wedge: Torque 40Nm

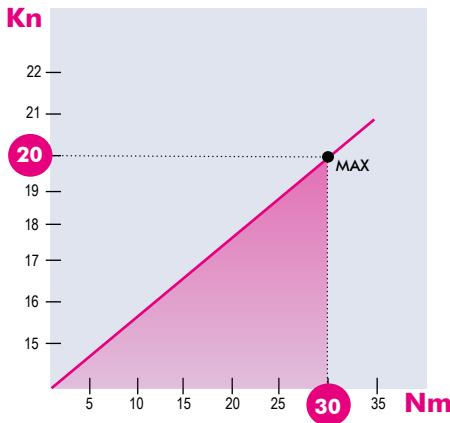

Art. 357

Morse tipo Vises type

2

Cuneo di spinta:
Momento massimo applicato 120Nm
Clamping wedge: Torque 120Nm

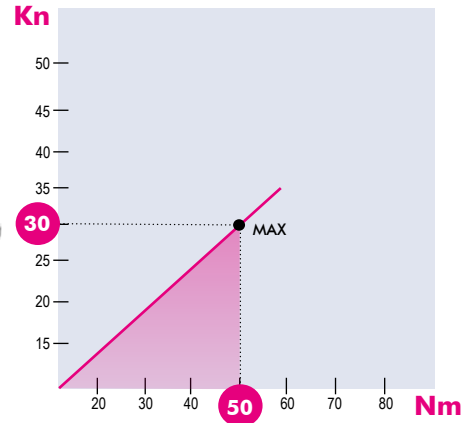

6

Gruppi di serraggio meccanici / Mechanical clamping device

I diagrammi seguenti consentono di determinare le forze di serraggio ottenibili con le morse di varia grandezza (da 1 a 3), in funzione della forza applicata.
The following diagrams give the clamping force that can be obtained with each vise type (size 1 to 3) depending on the force torque.

Morse tipo Vises type

3

Cuneo di spinta:
Momento massimo applicato 150Nm
Clamping wedge: Torque 150Nm

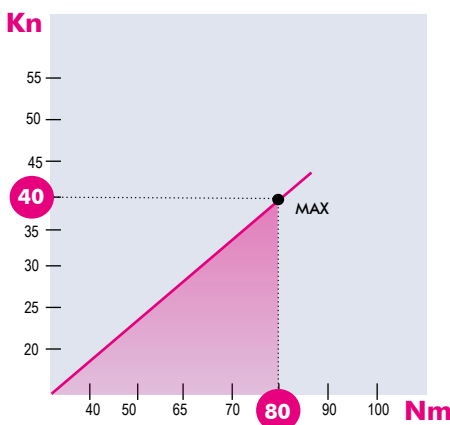



Art. 357

NB: Alcuni fattori, come la lubrificazione, lo staffaggio, gli attriti ed altro, possono modificare i valori indicati fino a $\pm 10\%$. Per un corretto utilizzo non superare i valori indicati nel grafico.
Some factor as lubrication, clamping on the machine table, frictions and more can modify above values within a $\pm 10\%$ range. For optimum operation do not exceed chart values.

MONTAGGIO MORSE in VERTICALE su CUBO INTERFACCIATO

WISE VERTICAL MOUNTING on COMPLETELY INTERFACED TOMBSTONES

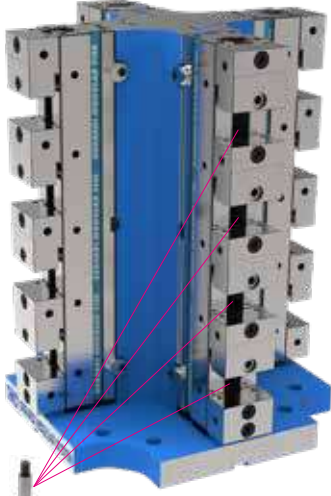

Cubo lavorato Art.57G Machined cube Art.57G	Tipo di morsa Vise type	Montaggio e allineamento* Mounting & alignment*	Cubo con morse Cube with vises
<p>Cod. 8.57.G00105 Dim. A=200 / B=500 / E= 80 H=650</p> 	<p>Art.600 Tipo 2x600</p>  <p>n°morse Vises n° x 4</p>	<p>Per morsa / each vise</p>  <p>Importo per montaggio ed allineamento di ogni morsa. Amount need for each vise mounting and alignment.</p>	 <p>Art.83</p>

* Montaggio e allineamento morse incluso di viti, chiavette, staffe e quant'altro necessario.
Vises mounting and alignment includes screws, keyways, holding clamps and all the necessary equipment.

Certificato di collaudo € 204
Certificate test € 204

PREDISPOSIZIONE e MONTAGGIO MORSE su SPALLA a RETICOLO

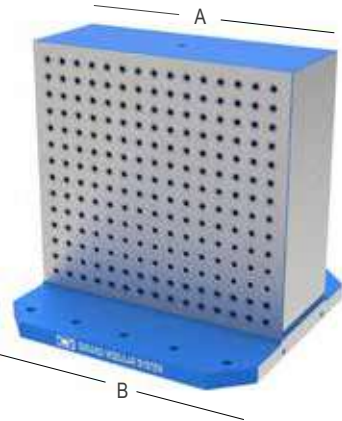
TOMBSTONES SET-UP and VISES MOUNTING on 2 SIDES GRID TOMBSTONE

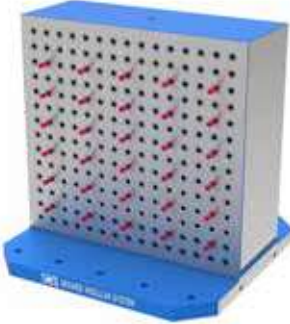
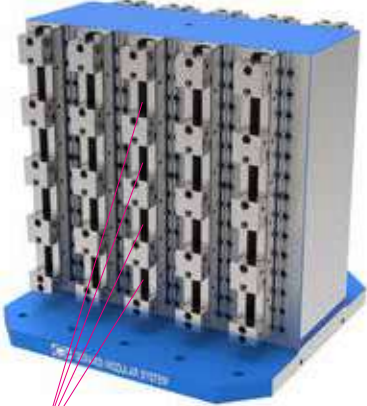
Spalla a reticolo Art.55F 2 sides grid tombstone Art.55F	Tipo di morsa Vise type	Predisposizione e montaggio* Set-up & Mounting*	Spalla con morse 2 sides tombstone with vises
<p>Cod. 8.55.F00191 Dim. A=800 / B=800 / H=800</p> 	<p>Art.600 Tipo 2x700</p>  <p>n°morse Vises n° x 10</p>	<p>Per morsa / each vise</p>  <p>Importo per montaggio ed allineamento di ogni morsa. Amount need for each vise mounting and alignment.</p>	 <p>Art.83</p>

* Predisposizione facce, montaggio ed allineamento morse incluso di viti, chiavette, staffe e quant'altro necessario.
Faces set-up, vises mounting including screws, keyways, holding clamps and all the necessary equipment.

Certificato di collaudo € 204
Certificate test € 204

Soluzioni personalizzate / Customized solutions

MULTIFLEX

Soluzioni personalizzate a tutti i vostri problemi di serraggio

Customized solutions for all your clamping problems

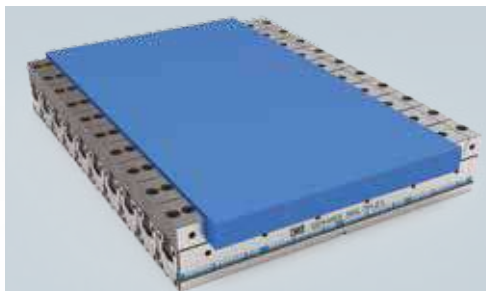

Montaggio in parallelo

Parallel mounting

n° 10 morse Multiflex montate in parallelo per il serraggio di un pezzo di grosse dimensioni

10 Multiflex vises parallel mounting for clamping a big size workpiece

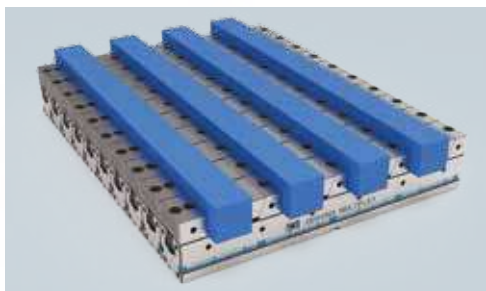

Montaggio in parallelo

Parallel mounting

n° 10 morse Multiflex montate in parallelo per il serraggio di 4 pezzi di grosse dimensioni

10 Multiflex vises parallel mounting for clamping a 4 big size workpieces

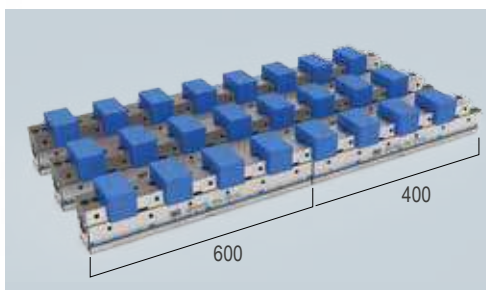

Montaggio in linea

In line mounting

n° 6 morse Multiflex montate in linea per il serraggio di 24 piccoli pezzi

6 Multiflex vises in line mounting for clamping a 24 small workpieces

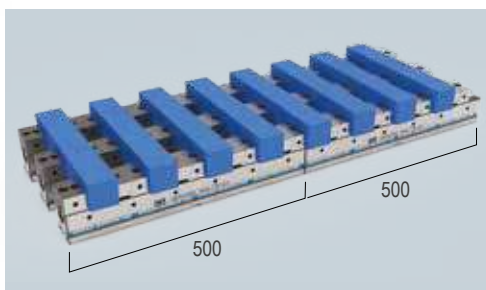

Montaggio in linea

In line mounting

n° 6 morse Multiflex montate in linea per il serraggio di 8 pezzi di grosse dimensioni

6 Multiflex vises in line mounting for clamping a 8 big size workpieces

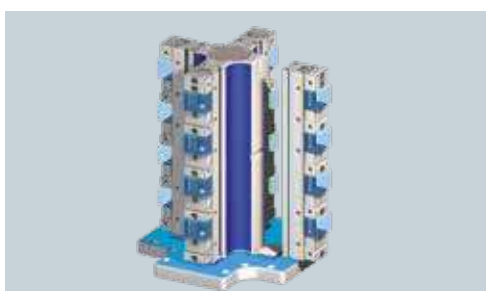

Cubo Morsa

Tombstone + vises

Cubo a croce Art.57G con vari tipi di morse Gerardi montate verticalmente

Crosscube Art.57G with various Gerardi vises vertically assembled

DIVISORE AUTOMATICO DPG 250

AUTOMATIC DIVIDING HEAD DPG 250

Divisore automatico
Automatic dividing head

Dati tecnici
Technical Data

DPG 250

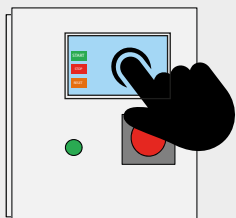
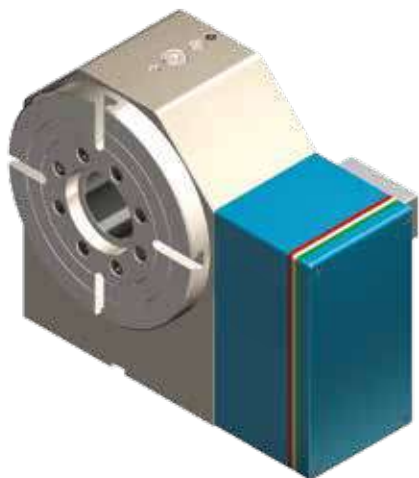

PROGRAMMAZIONE TOUCH SCREEN
FACILE ED INTUITIVA O TRAMITE COLLEGAMENTO
DIRETTO AL CNC

EASY AND INTUITIVE TOUCH SCREEN
PROGRAMMING OR THROUGH DIRECT
CONNECTION TO THE CNC

- Installazione semplice (alimentazione 220V)
- Corona in bronzo speciale
- Controsupporto semplice
- Vite senza fine in acciaio temprato e rettificato
- Vite e corona in bagno d'olio
- Cuscinetti a vite precaricati
- Cuscinetto anteriore a rulli incrociati sovradimensionato
- Recupero gioco con avvicinamento assiale
- Completa tenuta stagna ai liquidi con possibilità di pressurizzazione
- Possibilità di montare motori di tutte le marche
- Dimensioni esterne contenute
- Finestra di controlli liquidi e condensa
- Lavorazione in posizionamento a 360°

- Easy installation (220V)
- Special bronze crown
- Simple tailstock
- Worm screw in hardened ground steel
- Bath lubrication Screw and Crown
- Pre-loaded screw bearings
- Over-dimensioned crossed-roller front bearing
- Play recover with axial approach
- Watertight seal with possibility of pressurization
- Possibility to mount motors of all brands
- Reduced external dimensions
- Condensation and liquid control window
- 360° work positioning

Diametro del divisore Dividing head diameter		250 mm
Diametro del foro passante Clearance hole diameter		70,5 mm
Altezza punta Center height		200 mm
Dimensione della scanalatura a T T-Slot width		12 mm
Sistema di bloccaggio Clamping system		Idrraulico Hydraulic
Forza frenante Clamping torque		3000 Nm
Motore Servo motor		3000 Max.g/min
Minimo incremento Minimum increment		0,002
Velocità di rotazione Rotation speed		33,3 Giri/min
Rapporti vite/corona Speed reduction ratio (screw/gear)		1/90
Rapporti vite/motore Speed reduction ratio (screw/motor)		1/180
Precisione Indexing accuracy		±10 Sec.
Ripetibilità Repeatability		4 Sec.
Max. carico di lavoro sul divisore Max. allowable work weight on the dividing head	Verticale Vertical	Kg.550
	Orizzontale Horizontal	Kg.1500
Max. carico di spinta applicabile sul divisore Max. allowable tool load on the dividing head		N 25000
		FxL Nm 1000
		FxL Nm 2200
Rapporti vite/corona Speed reduction ratio (screw/gear)	Verticale Vertical	10,5 Kg. m ²
Coppia in lavoro Driving torque	Corona dentata Worm gear	698 Nm
Kg		110
Cod.		8.DP.G2500

DPG 250

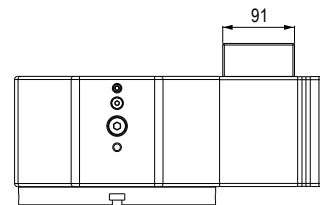
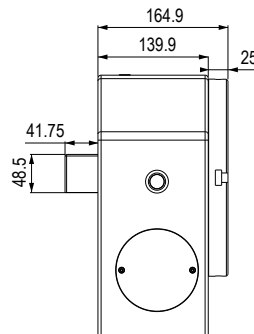
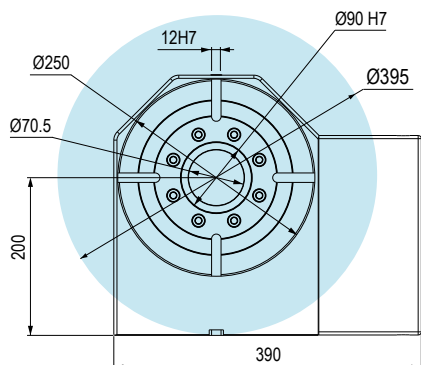

Tipo (grandezza) / Type (size)		1					2			
Divisore Gerardi DPG250 con cubo-morsa MULTIFLEX per il serraggio di particolari di tutte le forme e dimensioni.	C ⁻⁰ _{-0,02}	100					150			
	D	300	400	500	600	700	400	500	600	700
	G ⁻⁰ _{-0,02}	50					75			
	Ø I ^{H7}	25					50			
	L ⁻⁰ _{-0,02}	20					20			
Cod.	6.DP.G25000	6.DP.G25010	6.DP.G25020	6.DP.G25030	6.DP.G25040	6.DP.G25050	6.DP.G25060	6.DP.G25070	6.DP.G25080	

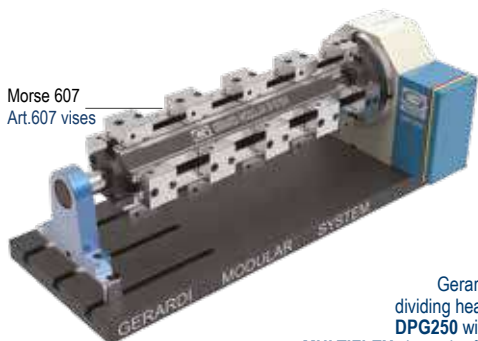
 Morse 607
 Art.607 vises

 Gerardi
 dividing head
DPG250 with
MULTIFLEX vise-cube for
 clamping workpieces of all
 shapes and sizes.

Nel caso si disponga di un proprio divisore, il prezzo dell'attrezzatura potrebbe subire variazioni
 In case you already have a diver, the price may be revised

UPGRADE YOUR VISE APPLICATIONS THROUGH MODULAR ACCESSORIES !
Art. 99A

 Supporto
 Support

Cod. 7.99.A1000

Art. 99B

 Perno di centraggio completo
 di sistema d'allineamento
 Horizontal centering pin with alignment system

Cod. 6.99.B1000

6.99.B2000

Art. 99H

 Distanziale per supporto
 Spacer support

Cod. 6.99.H1000

Art. 62K
DPG 250

 Piastra di interfaccia per cubo MULTIFLEX
 completa di sistema d'allineamento
 Connecting plate with alignment system for MULTIFLEX

Cod. 6.62.K603A8

6.62.K603A9

Art. 99S

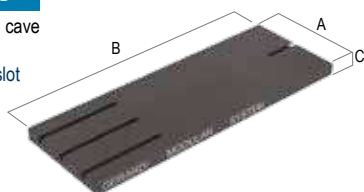
 Piastra base con cave
 Piani rettificati
 Base plate with slot
 Faces ground

Dimensioni B mm Dimension B mm	A	C	Kg	Cod.
600	400	50	94	7.99.S060S
800	400	50	125	7.99.S080S
1000	400	50	156	7.99.S100S

 Cave o fori calibrati su richiesta
 Slot or calibrated holes on request

Disponibili quote "B" a step di 50mm - Available dimension "B" in steps of 50mm

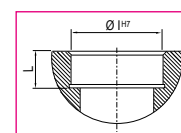
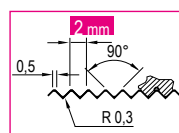
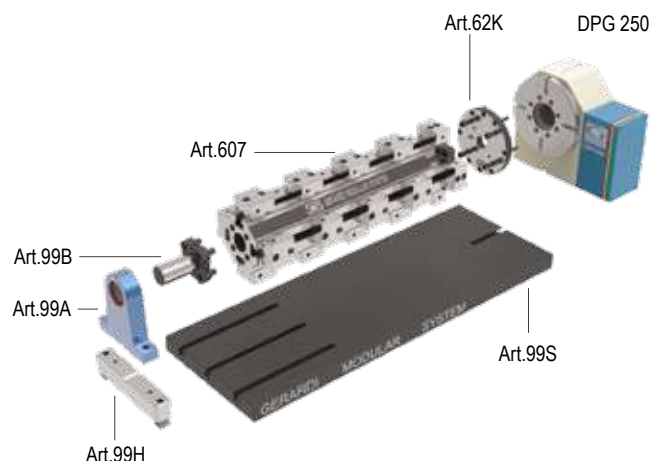
 Foro di centraggio
 Centering hole

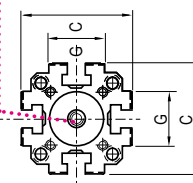
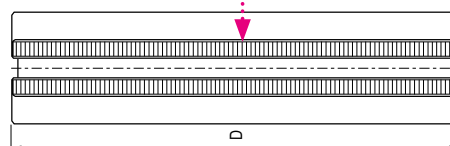
 2 mm =
 Passo delle righe
 Rows pitch

DIVISORE MECCANICO DIVIGER 205

MECHANICAL DIVIDING HEAD DIVIGER 205

Divisore automatico
Automatic dividing head

Dati tecnici
Technical Data

DIVIGER 205



Diametro del divisore Dividing head diameter	220 mm
Diametro del foro passante Clearance hole diameter	85 mm
Altezza centrale Center height	200 mm
Dimensione della scanalatura a T T-Slot width	-
Sistema di bloccaggio Clamping system	Meccanico Mechanical
Minimo incremento Minimum increment	1°
Precisione Indexing accuracy	±10 Sec.
Coppia in lavoro Driving torque	 3000 Nm
Kg	93
Cod.	7.66.73000

DIVISORE MECCANICO, SENZA CAVI O IDRAULICA,
PERMACCHINE A CNC

MECHANICAL DIVIDING HEAD, WITHOUT ELECTRICAL CABLES
OR HYDRAULIC, FOR CNC MILLING MACHINE

- Maggiore efficienza nella lavorazione su più lati
- Completamente autonomo dalla macchina
- Elevato momento torcente
- Divisione manuale o automatica tramite mandrino macchina
- 360 posizioni
- Serraggio simultaneo di due particolari grazie alla doppia flangia
- lavorazione su 5 facce senza contropunta
- Lavorazione a barra grazie al mandrino cavo
- Utilizzabile orizzontalmente o verticalmente
- Cambio tramite serraggio a cuneo
- Cost-effective on multiple-sides machining
- Machine independent
- High holding torque
- Dividing manually or automatically using the machine spindle
- 360 x 1° division
- Simultaneous clamping of 2 workpieces thanks to the dual flange
- 5 faces machining without counter-holder
- Bar machining due to hollow spindle
- To be used horizontally or vertically
- Quick change through wedge clamping

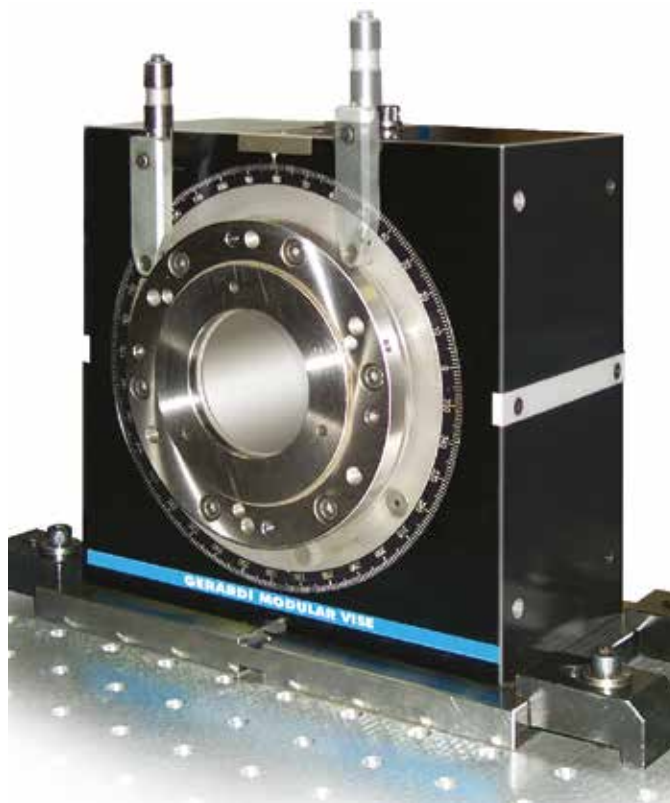

DIVIGER 205

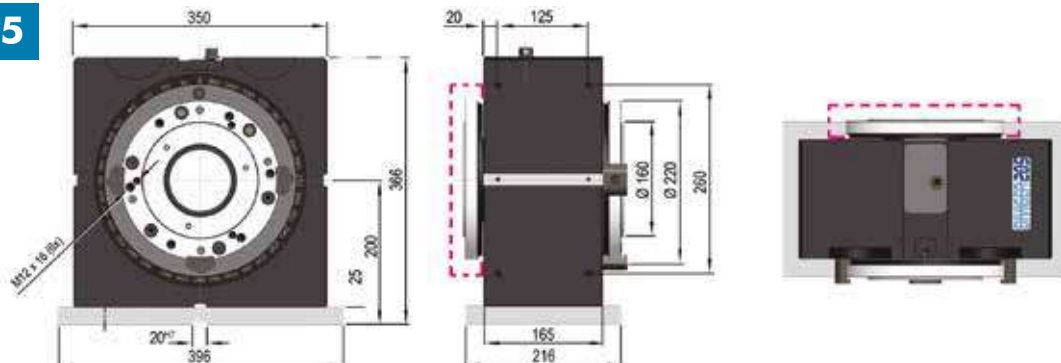

Tipo (grandezza) / Type (size)	1					2			
C ⁻⁰ / _{-0.02}	100					150			
D	300	400	500	600	700	400	500	600	700
G ⁻⁰ / _{-0.02}	50					75			
Ø I ^{H7}	25					50			
L ⁻⁰ / _{-0.02}	20					20			
Cod.	6.DI.V20500	6.DI.V20510	6.DI.V20520	6.DI.V20530	6.DI.V20540	6.DI.V20550	6.DI.V20560	6.DI.V20570	6.DI.V20580

Divisore Gerardi **DIVIGER 205** con cubo-morsa **MULTIFLEX** per il serraggio di particolari di tutte le forme e dimensioni.

Morse 607
Art.607 vises

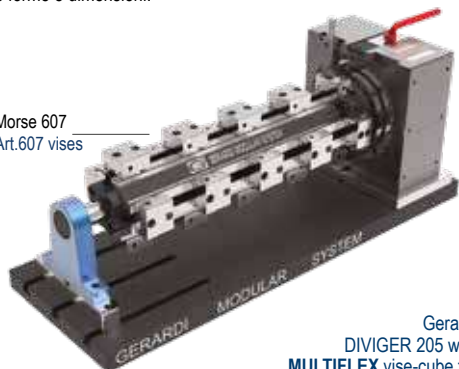

Gerardi **DIVIGER 205** with **MULTIFLEX** vise-cube for clamping workpieces of all shapes and sizes.

Nel caso si disponga di un proprio divisore, il prezzo dell'attrezzatura potrebbe subire variazioni
In case you already have a diviger, the price may be revised

UPGRADE YOUR VISE APPLICATIONS THROUGH MODULAR ACCESSORIES !

Art. 99A

Supporto
Support



Cod. 7.99.A1000

Art. 99B

Perno di centraggio completo di sistema d'allineamento
Horizontal centering pin with alignment system



Cod. 6.99.B1000 6.99.B2000

Art. 99H

Distanziale per supporto
Spacer support



Cod. 6.99.H1000

Art. 62K DIVIGER 205

Piastra di interfaccia per cubo MULTIFLEX completa di sistema d'allineamento
Connecting plate with alignment system for MULTIFLEX



Cod. 6.62.K603A8 6.62.K603A9

Art. 99S

Piastra base con cave
Piani rettificati
Base plate with slot
Faces ground

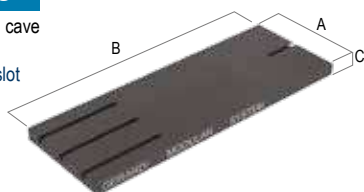

Dimensioni B mm Dimension B mm	A	C	Kg	Cod.
600	400	50	94	7.99.S060S
800	400	50	125	7.99.S080S
1000	400	50	156	7.99.S100S

Cave o fori calibrati su richiesta
Slot or calibrated holes on request

Disponibili quote "B" a step di 50mm - Available dimension "B" in steps of 50mm

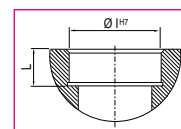
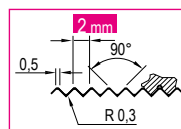
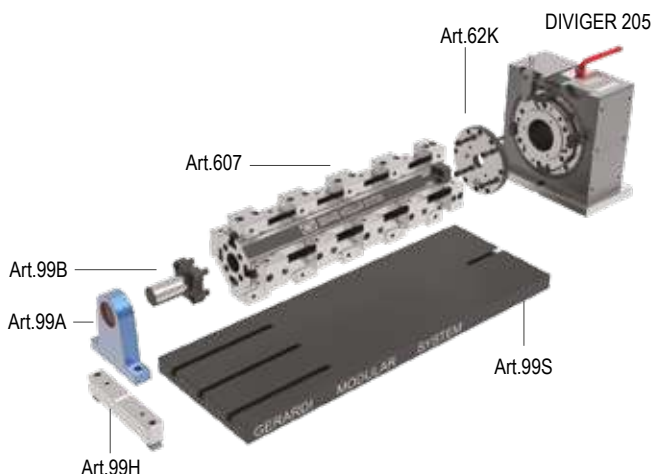

Foro di centraggio
Centering hole

2 mm =
Passo delle righe
Rows pitch

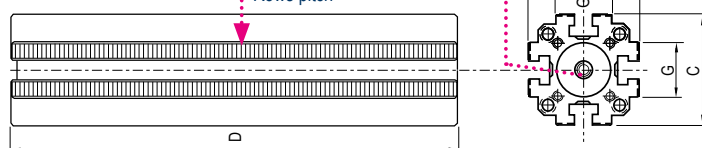

ISTRUZIONI PER UN CORRETTO UTILIZZO

INSTRUCTIONS FOR A PROPER USE



Libretto Istruzioni / Instruction Book

Scansiona il QR code e scarica le istruzioni complete

Scan the QR code to download the complete instructions

TOLLERANZE GEOMETRICHE

GEOMETRIC ACCURACIES

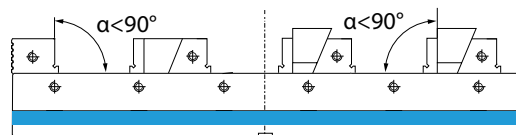
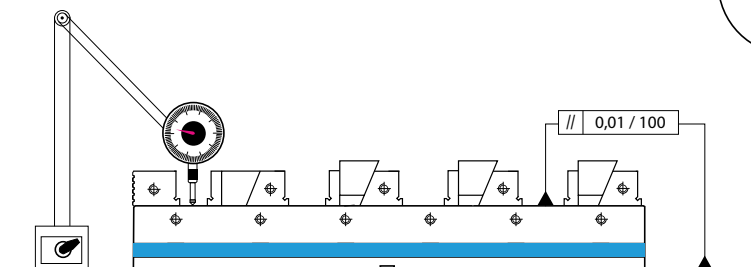
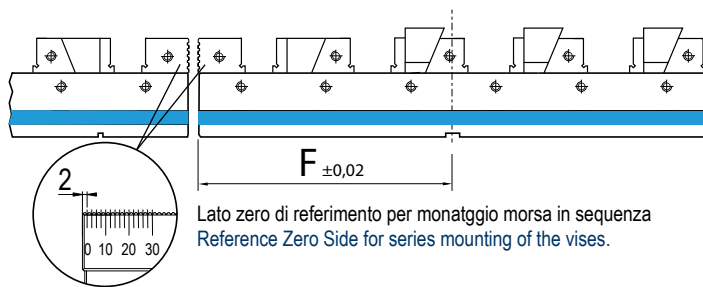
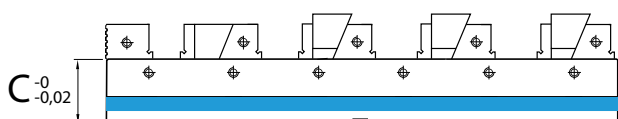

TOLLERANZE DINAMICHE

DINAMIC ACCURACIES

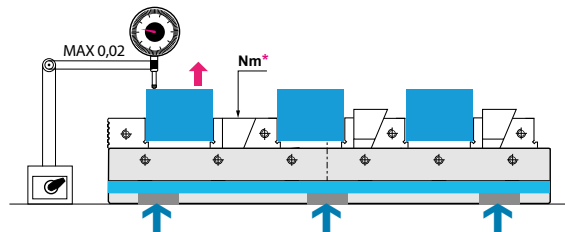
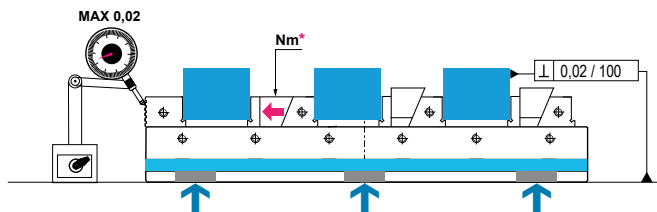

Morsa ancorata con 2 coppie di staffe Art. 296 / Vise clamped with n. 2 pairs of Art. 296

Art 600 - 606 - 611	* Momento applicato - Torque Nm			Forza di serraggio - Clamping power KN			
	Ganascia fissa e Cuneo di posizionamento Fixed jaw and positioning Wedge	Cuneo di spinta - Clamping movable Jaw			Cuneo di spinta - Clamping movable Jaw		
		Morsa - Vise Art. 600	Morsa - Vise Art. 606	Morsa - Vise Art. 611	Morsa - Vise Art. 600	Morsa - Vise Art. 606	Morsa - Vise Art. 611
Ganascia Tipo 1 Jaw Type 1	40	30		20			
Ganascia Tipo 2 Jaw Type 2	120	50		30			
Ganascia tipo 3 Jaw Type 3	250	80		40			

1 kgf . m = 9.806 Nm